

100% REVIEW

BURNEY WATER DISTRICT

CONTRACT DOCUMENTS

FOR CONSTRUCTION OF

WASHBURN BUE DOG PARK PROJECT

**THIS PROJECT IS FUNDED IN PART THROUGH
THE STATE OF CALIFORNIA - NATURAL RESOURCES AGENCY
DEPARTMENT OF PARKS AND RECREATION PER CAPITA GRANT
PROGRAM PROJECT No. 18-45-006**

APRIL 2023

JOB No. 306.45



**FOR INFORMATION ON THIS PROJECT, CONTACT
RYAN TURNER OR TROY JONES AT 530-244-0202**

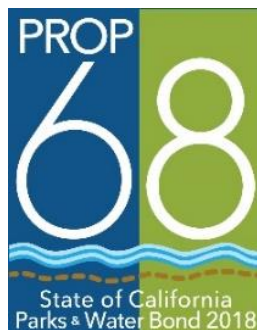

PROJECT MANUAL

WASHBURN BUE DOG PARK PROJECT

FOR

BURNEY WATER DISTRICT

**20222 Hudson Street
Burney, CA 96013**

JOB No. 306.45

APRIL 2023

**PACE ENGINEERING, INC.
5155 VENTURE PARKWAY, REDDING, CALIFORNIA 96002
530-244-0202 FAX: 530-244-1978**

**FOR INFORMATION ON THIS PROJECT, CONTACT
RYAN TURNER OR TROY JONES AT 530-244-0202**

CHECKED BY _____

TABLE OF CONTENTS

<u>SECTION</u>	<u>PAGE</u>
ADVERTISEMENT FOR BIDS.....	1
INSTRUCTIONS TO BIDDERS.....	3
BIDDER’S CHECKLIST	7
PROPOSAL.....	8
INFORMATION REQUIRED OF BIDDER.....	10
LIST OF SUBCONTRACTORS.....	12
BID BOND (PENAL SUM FORM).....	13
NON COLLUSION AFFIDAVIT TO BE EXECUTED BY BIDDER AND SUBMITTED WITH BID.....	16
DRUG-FREE WORKPLACE CERTIFICATION.....	17
CONTRACTOR’S CERTIFICATION REGARDING WORKERS’ COMPENSATION INSURANCE.....	18
NOTICE OF AWARD	19
AGREEMENT.....	20
PERFORMANCE BOND.....	23
PAYMENT BOND.....	27
GENERAL PROVISIONS	30
NOTICE TO PROCEED	31
CONTRACTOR’S APPLICATION FOR PAYMENT.....	32
CERTIFICATE OF SUBSTANTIAL COMPLETION.....	39
WORK CHANGE DIRECTIVE	40
CHANGE ORDER	41
RELEASE OF CLAIMS.....	SP-21

DRAWINGS

Sheet Numbers 1 through 6 – At End of Text

ADVERTISEMENT FOR BIDS

Burney Water District ("District" or "Owner") invites separate sealed bids ("Proposal" or "Bid") for the construction of the Washburn Bue Dog Park Project (Project) from qualified contractors ("Contractor" or "Bidder").

The work consists of constructing an 18,000-square-foot fenced-in dog park in the northwest corner of the Washburn Bue Park. The dog park will have a fenced barrier to divide it into two sections and a double-gated entrance. A Conex box is currently being used for storage and will need to be relocated. A five-foot-wide paved path will be constructed from the parking area to the dog park, and a five-foot-wide decomposed granite (DG) access path will be constructed within the dog park area. Additional tables, water fountains, trash receptacles, water service, and benches will be installed as part of this Project.

The construction cost range is \$120,000 to \$160,000 Bids will be received at _____ until _____ daylight pacific time, _____. Bids will be opened at or after the time indicated for receipt of bids.

The Contract Documents may be examined at the following locations:

- Burney Water District, 20222 Hudson St., Burney, CA 96013
- PACE Engineering, Inc., 5155 Venture Parkway, Redding, CA 96002

The Owner is using a third-party website, CIPLIST.com, to advertise these Bidding Documents. CIPLIST.com is a free service provided to review and download project Bidding Documents. CIPLIST.com is the only internet website for prospective bidders to obtain official project information and Bidding Documents for this project.

****DISCLAIMER REGARDING BID DOCUMENTS****

Electronic Bidding Documents are provided electronically and free of charge. It is the responsibility of each prospective bidder to verify the completeness of their printed Bidding Documents before submitting their bid and accompanying executed addenda acknowledgment forms. Users are cautioned that the Owner does not assume any liability or responsibility based on any defective or incomplete copying, excerpting, scanning, faxing, downloading or printing of the Contract Documents.

Be advised that the information contained on CIPLIST.com may change without notice to prospective bidders. It is the responsibility of each prospective bidder to check CIPLIST.com on a daily basis through the close of bids for any applicable addenda or updates.

Copies of referenced Standard Specifications for Public Works Construction, 2018 Edition, commonly called the "Green Book," containing the General Provisions and Standard Technical

Specifications, may be obtained from Building News, Inc., 1612 South Clementine Street, Anaheim, CA 92802, (714) 517-0970.

The general prevailing wage rate of per diem wages, holidays, and overtime work for each craft, classification, or type of workman needed to execute the Contract are established by the State of California, Department of Industrial Relations, and can be obtained from www.dir.ca.gov/DLSR/PWD. It shall be mandatory for the Contractor to whom the Contract is awarded and any subcontractor to pay not less than the said specified prevailing rates of wages to all workmen employed in the execution of the Contract. Contractors shall pay rates not less often than once per week.

Each Bid shall be made in accordance with the Specifications and Proposal requirements thereof, and no bid will be received unless it is made on Proposal forms included in the Contract Documents. Each bid must be accompanied by cashier's check or Bidder's Bond made payable to Burney Water District for an amount equal to at least ten percent (10%) of the total amount of the Bid as a guarantee that the Contractor will execute the Contract in conformance with the Proposal and the Specifications. Such guarantee shall be forfeited should the bidder to whom the Contract is awarded fail to enter into the Contract.

No bid will be accepted from a Contractor who does not hold a Class A license in accordance with the provisions of Section 3300 of the California Public Contract Code, or who does not meet the proof of experience requirements as described in Item G of the Instructions to Bidders.

No Contractor or subcontractor may be listed on a Bid Proposal for a public works project unless registered with the Department of Industrial Relations pursuant to Labor Code Section 1725.5 [with limited exceptions from this requirement for bid purposes only under Labor Code Section 1771.1(a)].

The Owner reserves the right to accept or reject any and/or all Bids and to make that award which is in the best interest of the Owner.

INSTRUCTIONS TO BIDDERS

A. PROPOSAL FORMAT

Each Proposal must be submitted in a sealed envelope, addressed to the Owner at the office where bids will be received as stated in the Advertisement for Bids. Each sealed envelope containing a Proposal must be plainly marked on the outside as PROPOSAL FOR WASHBURN BUE DOG PARK PROJECT, and the envelope should bear on the outside the name of the Bidder and its address.

All Proposals shall be made on the required Proposal form. All blank spaces for Bid prices shall be filled in, in ink or typewritten, and the Proposal form shall be fully completed and executed when submitted. Any corrections to entries made on Proposal forms shall be initialed by the person signing the Proposal. In case of discrepancy between unit prices and total shown in the Proposal, unit prices shall prevail. Only one copy of the Proposal form is required unless otherwise specified. Additional sheets required to fully respond to requested information are permissible. All items listed on the Bidder's Checklist shall be included to constitute a complete Proposal.

The Owner may waive any informalities or minor defects or reject any and all Proposals. Any Proposal may be withdrawn either personally or by written request prior to the above-scheduled time for the opening of Proposals or authorized postponement thereof. Modifications to Proposals already submitted will be allowed if received in writing prior to the time fixed in the Advertisement for Bids for opening of Proposals. Any Proposal received after the time and date specified shall not be considered.

B. BIDDER'S UNDERSTANDING

Bidders must satisfy themselves as to the accuracy of the estimated quantities in the Bid Schedule by examination of the site and a review of the Contract Documents. If the Bidder determines any errors or inaccuracies in the Contract Documents, he shall immediately notify the Engineer. After Proposals have been submitted, the Bidder shall not assert that there was a misunderstanding concerning the quantities of work or of the nature of the work to be done.

Each Bidder is responsible for inspecting the site and for reading and being thoroughly familiar with the Contract Documents. The failure or omission of any Bidder to do any of the foregoing shall in no way relieve any Bidder from any obligation with respect to its Proposal.

The Contract Documents contain the provisions required for the construction of the Project. Information obtained from an officer, agent, or employee of the Owner or the Engineer or any other person shall not affect the risks or obligations assumed by the Contractor or relieve them from fulfilling any of the conditions of the Contract.

All information or responses of a Bidder in its Bid Proposal and other documents accompanying the Bid Proposal shall be complete, accurate and true. Incomplete, inaccurate, or untrue responses or information provided therein by a Bidder shall be grounds for the District to reject such Bidder's Bid Proposal, in the District's sole discretion, for nonresponsiveness.

C. PROPOSAL GUARANTEE

Each Proposal must be accompanied by a Proposal Guarantee, consisting of either cash, a Bid Bond payable to the Owner, a cashier's check payable to the Owner, or a certified check in the name of the Owner. The Proposal Guarantee shall be in the amount of ten percent (10%) of the total amount of the Proposal. As soon as the Bid prices have been compared, the Owner will, upon written request, return the Proposal Guarantees of all except the three lowest responsible Bidders. When the Agreement is executed, the Proposal Guarantees of the two remaining unsuccessful Bidders will be returned, upon written request. The Proposal Guarantee of the successful Bidder will be retained until the Payment Bond and the Performance Bond have been executed and approved, after which it will be returned. Unless specifically requested by Bidders, Bid Bonds will not be returned, but will be considered void when Proposal Guarantees would have otherwise been returned. A Bidder's Bond will be accepted only if it is made out on either the Bidder's Bond form enclosed in these Documents or on a form that conforms to it. The bonds must be executed by a duly licensed surety company which is listed in the latest circular 570 of the United States Treasury Department as being acceptable as a surety on federal bonds.

A Performance Bond and a Payment Bond, each in the amount of 100% of the total contract amount as stipulated in the General Provisions, will be required for the faithful performance of the Contract.

Attorneys-in-fact who sign Bid Bonds or Payment Bonds and Performance Bonds must file with each Bond a certified and effective dated copy of their power of attorney.

D. AWARD OF CONTRACT

No Bidder may withdraw a Proposal within 60 days after the actual date of the opening thereof. Should there be reasons why the Contract cannot be awarded within the specified period, the time may be extended by mutual agreement between the Owner and the Bidder.

The party to whom the Contract is awarded will be required to execute the Agreement and obtain the Performance Bond, Payment Bond, and insurance certificates as specified in the Contract Documents within fifteen (15) calendar days from the date when Notice of Award is delivered to the Bidder. The Notice of Award shall be accompanied by the necessary Agreement and Bond forms. In case of failure of the Bidder to execute the Agreement, the Owner may, at its option, consider the Bidder in default, in which case the Proposal Guarantee accompanying the Proposal shall become the property of the Owner.

The Owner, within ten (10) calendar days of receipt of acceptable Performance Bond, Payment Bond, Agreement signed by the party to whom the Agreement was awarded, and insurance certificates, shall sign the Agreement and return to such party an executed duplicate of the Agreement. Should the Owner not execute the Agreement within such period, the Bidder may by written notice withdraw their signed Agreement. Such notice of withdrawal shall be effective upon receipt of the notice by the Owner.

The Notice to Proceed shall be issued within ten (10) calendar days of the execution of the Agreement by the Owner and approval by the District's Board. Should there be reasons, through no fault of the Contractor, why the Notice to Proceed cannot be issued within such period, the time may be extended by mutual agreement between the Owner and Contractor. If, through no fault of the Contractor, the Notice to Proceed has not been issued within the ten (10) day period or within the period mutually agreed upon, the Contractor may terminate the Agreement without further liability on the part of either party.

The Owner may make such investigations as he deems necessary to determine the ability of the Bidder to perform the work, and the Bidder shall furnish to the Owner all such information and data for this purpose as the Owner may request. The Owner reserves the right to reject any Proposal if the evidence submitted by, or investigation of, such Bidder fails to satisfy the Owner that such Bidder is properly qualified to carry out the obligations of the Agreement and to complete the work contemplated therein.

Award will be made to the lowest responsible Bidder submitting a responsive proposal.

If, at the time this Contract is to be awarded, the total of the lowest responsive Proposal exceeds the funds then estimated by the Owner as available, the Owner may reject all bids or take such other action as best serves the Owner's interests.

E. LIST OF SUBCONTRACTORS & REGISTRATION

As stipulated in the General Provisions, Section 2-3.1, each Bidder shall submit with their Proposal a list showing the name, address, and type of work to be performed by each subcontractor who will be employed by the Contractor in performance of the work in the amount of more than one-half of one percent of the total Contract amount ("Subcontractors List"). If the Bidder fails to specify a subcontractor for any portion of the work to be performed under the Contract, the Bidder agrees to perform that portion of the work itself.

An inadvertent error in listing the California contractor license number on the Subcontractors List shall not be grounds for filing a bid protest or grounds for considering the bid nonresponsive if the correct contractor's license number is submitted to the District within 24 hours after the bid opening and the corrected number corresponds with the submitted name and location for that subcontractor.

No Contractor or subcontractor may be listed on a Bid Proposal for a public works project unless registered with the Department of Industrial Relations pursuant to Labor Code Section 1725.5 [with limited exceptions from this requirement for bid purposes only under Labor Code Section 1771.1(a)]. The subcontractor's registration must remain active throughout the term of the Contract.

An inadvertent error listing an unregistered subcontractor shall not be grounds for filing a bid protest or grounds for considering the bid nonresponsive provided that any of the following apply:

- (1) The subcontractor is registered prior to the bid opening.
- (2) The subcontractor is registered and has paid the penalty registration fee within 24 hours after the bid opening.
- (3) The subcontractor is replaced by another registered subcontractor pursuant to Public Contract Code section 4107.

F. ADDENDA AND EXPLANATIONS TO BIDDERS

Any explanation regarding the meaning or interpretation of Plans, Specifications, or other Contract Documents must be requested in writing, with sufficient allowance of time for receipt of reply before the time set for opening of Proposals. Any such explanations or interpretations shall be made in the form of Addenda to the Documents and shall be furnished to all Bidders, who shall acknowledge receipt of all Addenda in their Proposal. Oral explanations and interpretations shall not be binding.

G. LICENSING REQUIREMENTS FOR BIDDERS/CONTRACTORS

All Bidders, including General Contractors and specialty Contractors, shall hold such licenses as may be required by the laws of the State of California for the performance of the work specified in the Contract Documents. The prime Contractor shall hold a Class A license.

H. TAXES AND OTHER FEES

The prices submitted in the Proposal shall include all sales taxes, other taxes, and applicable fees.

BIDDER'S CHECKLIST

This checklist has been prepared and furnished to aid bidders in including all necessary supporting information with their bid. Bidders' submittals should include, but are not limited to, the following:

Item	No. of Pages	Checked
A. Bid (Proposal)	1	
B. Information Required of Bidder	2	
C. List of Subcontractors	1	
D. Bid Bond or Other Proposal Guarantee	2	
E. Non-Collusion Affidavit	1	
F. Drug-Free Workplace Certification	1	
G. Contractor's Certification Regarding Workers' Compensation Insurance	1	
H. Power of Attorney (only if applicable, form not included)		
I. Authority to Sign Bid Proposal (only if applicable, form not included)		

PROPOSAL

Proposal of _____ (hereinafter called "Bidder"), organized and existing under the laws of the State of _____, doing business as _____ (Insert "a corporation," "a partnership," or "an individual" as applicable) to the Burney Water District (hereinafter called "Owner").

Bidder hereby proposes to perform all work for the construction of the Washburn Bue Dog Park Project in strict accordance with the Contract Documents, within the time set forth therein, and at the prices stated below.

By submission of this Proposal, each Bidder certifies; and in the case of a Joint Proposal, each party thereto certifies as to its own organization that its Proposal has been arrived at independently without consultation, communication, or agreement as to any matter relating to this Proposal with any other Bidder or with any competitor.

Bidder acknowledges receipt of the following Addenda:

Addendum No.	Addendum Date

Bidder agrees to perform all the work described in the Contract Documents at the indicated unit prices:

Item No.	Description	Unit	Est Qty	Bid Unit Price	Bid Amount
1	Demolition	1	LS		\$
2	Grading	1	LS		\$
3	HMA Path (2" HMA over 6" AB)	450	SF	\$	\$
4	Decomposed Granite (6" thick)	1,840	SF	\$	\$
5	6' high Chain Link Fence, complete	295	LF	\$	\$
6	5' high Chain Link Fence, complete	460	LF	\$	\$
7	1" Water Line, Irrigation Line, and Accessory, complete	202	LF	\$	\$
8	Park Accessories	1	LS		\$
Total of All Unit Price Bid Items:					\$

Respectfully submitted,

Date: _____

Signature

Title

Address

California Contractor License Number

Attest: _____

INFORMATION REQUIRED OF BIDDER

The Bidder shall furnish the following information, except for item 4, at the time of Bid Opening. The apparent low Bidder shall submit item 4 within five calendar days post bid. Additional sheets shall be attached as required. Failure to properly complete this form will cause the bid to be non-responsive and may cause its rejection. In any event, no award will be made until all of the information required of the Bidder is delivered to the Owner.

- 1) Bidder's Name, Address, and Phone Numbers:

Name: _____

Address: _____

Phone No.: _____ Fax No.: _____

- 2) Bidder's Contractor License Information:

Primary Classification: _____

California State License No. and Expiration Date: _____

Specialty classifications held, if any: _____

Department of Industrial Relations Registration No.: _____

- 3) Name, address, and telephone number of surety company and agent who will provide the required bonds on this Contract:

- 4) ATTACH TO THIS BID a financial statement, references, and other information, sufficiently comprehensive to permit an appraisal of Bidder's current financial condition. Financial statements attached to the Bid should be in a separate sealed envelope to be kept confidential and will not be subject to public review.

- 5) ATTACH TO THIS BID a list of five projects completed by the Contractor's proposed jobsite superintendent during the last 5 years involving work of similar type and complexity.

The list shall include the following information as a minimum:

- Names, address, and telephone number of Owner
- Name of project
- Location of project

- Brief description of the work involved
- Name, address, and telephone number of Engineer
- Contract Amount
- Date of Completion of Contract
- Amount of liquidated damages assessed against Contractor
- Nature and resolution of any claim, lawsuit, and/or arbitration between Contractor and the Owner

To be considered for award, the Bidder and the job site superintendent who will be assigned this project shall have completed at least five projects of similar type and complexity and comparable value. Bidders who meet the above qualifications shall ascertain before submission of their proposal that any other subcontractor listed in this Proposal shall also have these qualifications for their area of work.

LIST OF SUBCONTRACTORS

Per Section 4104 of the State of California Public Contract Code, each Bidder shall list below the name, the location of the place of business, and the California contractor license number of each subcontractor who will perform work or labor or render service to the prime contractor in or about the construction of the work or improvement, or a subcontractor licensed by the State of California who, under subcontract to the prime contractor, specially fabricates and installs a portion of the work or improvement according to detailed drawings contained in the plans and specifications, in an amount in excess of one-half of one percent of the prime contractor's total bid.

Bidders shall also list the portion of the work that will be done by each such subcontractor under this act. The prime Contractor shall list only one subcontractor for each such portion as is defined by the prime Contractor in the Bid.

Name and Location of Business	License No./DIR No.	Portion of Work	% of Total Contract
	License No.:		
	DIR No.:		
	License No.:		
	DIR No.:		
	License No.:		
	DIR No.:		
	License No.:		
	DIR No.:		

BID BOND (PENAL SUM FORM)

<p>Bidder Name: [Full formal name of Bidder] Address (<i>principal place of business</i>): [Address of Bidder's principal place of business]</p>	<p>Surety Name: [Full formal name of Surety] Address (<i>principal place of business</i>): [Address of Surety's principal place of business]</p>
<p>Owner Name: Burney Water District Address (<i>principal place of business</i>): 20222 Hudson St. Burney, CA 96013</p>	<p>Bid Project (<i>name and location</i>): Washburn Bue Dog Park Burney, CA</p> <p>Bid Due Date: [Enter date bid is due]</p>
<p>Bond Penal Sum: [Amount] Date of Bond: [Date]</p>	
<p>Surety and Bidder, intending to be legally bound hereby, subject to the terms set forth in this Bid Bond, do each cause this Bid Bond to be duly executed by an authorized officer, agent, or representative.</p>	
<p>Bidder</p>	<p>Surety</p>
<p style="text-align: center;"><i>(Full formal name of Bidder)</i></p>	<p style="text-align: center;"><i>(Full formal name of Surety) (corporate seal)</i></p>
<p>By: _____ <i>(Signature)</i></p>	<p>By: _____ <i>(Signature) (Attach Power of Attorney)</i></p>
<p>Name: _____ <i>(Printed or typed)</i></p>	<p>Name: _____ <i>(Printed or typed)</i></p>
<p>Title: _____</p>	<p>Title: _____</p>
<p>Attest: _____ <i>(Signature)</i></p>	<p>Attest: _____ <i>(Signature)</i></p>
<p>Name: _____ <i>(Printed or typed)</i></p>	<p>Name: _____ <i>(Printed or typed)</i></p>
<p>Title: _____</p>	<p>Title: _____</p>
<p><i>Notes: (1) Note: Addresses are to be used for giving any required notice. (2) Provide execution by any additional parties, such as joint venturers, if necessary.</i></p>	

1. Bidder and Surety, jointly and severally, bind themselves, their heirs, executors, administrators, successors, and assigns to pay to Owner upon default of Bidder the penal sum set forth on the face of this Bond. Payment of the penal sum is the extent of Bidder's and Surety's liability. Recovery of such penal sum under the terms of this Bond will be Owner's sole and exclusive remedy upon default of Bidder.
2. Default of Bidder occurs upon the failure of Bidder to deliver within the time required by the Bidding Documents (or any extension thereof agreed to in writing by Owner) the executed Agreement required by the Bidding Documents and any performance and payment bonds required by the Bidding Documents.
3. This obligation will be null and void if:
 - 3.1. Owner accepts Bidder's Bid and Bidder delivers within the time required by the Bidding Documents (or any extension thereof agreed to in writing by Owner) the executed Agreement required by the Bidding Documents and any performance and payment bonds required by the Bidding Documents and all other conditions to the contract between Bidder and Owner become effective, or
 - 3.2. All Bids are rejected by Owner, or
 - 3.3. Owner fails to issue a Notice of Award to Bidder within the time specified in the Bidding Documents (or any extension thereof agreed to in writing by Bidder and, if applicable, consented to by Surety when required by Paragraph 5 hereof).
4. Payment under this Bond will be due and payable upon default of Bidder and within 30 calendar days after receipt by Bidder and Surety of written notice of default from Owner, which notice will be given with reasonable promptness, identifying this Bond and the Project and including a statement of the amount due.
5. Surety waives notice of any and all defenses based on or arising out of any time extension to issue Notice of Award agreed to in writing by Owner and Bidder, provided that the total time for issuing Notice of Award including extensions does not in the aggregate exceed 120 days from the Bid due date without Surety's written consent.
6. Surety, for value received, hereby stipulates and agrees that no change, extension of time, alteration or addition to the terms of the Contract or the call for bids, or to the Work to be performed thereunder, or the specifications accompanying the same, shall in any way affect its obligation under this bond, and it does hereby waive notice of any such change, extension of time, alteration or addition to the terms of the Contract or the call for bids, or to the Work, or to the specifications.
7. No suit or action will be commenced under this Bond prior to 30 calendar days after the notice of default required in Paragraph 4 above is received by Bidder and Surety, and in no case later than one year after the Bid due date.
8. Any suit or action under this Bond will be commenced only in a court of competent jurisdiction located in the state in which the Project is located. In the event suit is brought upon this bond by the Owner and judgment is recovered, the Surety shall pay all costs incurred by the Owner in such suit, including a reasonable attorneys' fee to be fixed by the Court.
9. Notices required hereunder must be in writing and sent to Bidder and Surety at their respective addresses shown on the face of this Bond. Such notices may be sent by personal delivery, commercial courier, or by United States Postal Service registered or certified mail, return receipt requested, postage pre-paid, and will be deemed to be effective upon receipt by the party concerned.

10. Surety shall cause to be attached to this Bond a current and effective Power of Attorney evidencing the authority of the officer, agent, or representative who executed this Bond on behalf of Surety to execute, seal, and deliver such Bond and bind the Surety thereby.
11. This Bond is intended to conform to all applicable statutory requirements. Any applicable requirement of any applicable statute that has been omitted from this Bond will be deemed to be included herein as if set forth at length. If any provision of this Bond conflicts with any applicable statute, then the provision of said statute governs and the remainder of this Bond that is not in conflict therewith continues in full force and effect.
12. The term "Bid" as used herein includes a Bid, offer, or proposal as applicable.

**NON COLLUSION AFFIDAVIT TO BE EXECUTED BY BIDDER
AND SUBMITTED WITH BID**

(Public Contract Code Section 7106)

_____, being first duly sworn, deposes and says that he or she is _____ of _____, the party making the foregoing bid, that the bid is not made in the interest of, or on behalf of, any undisclosed person, partnership, company, association, organization, or corporation; that the bid is genuine and not collusive or sham; that the bidder has not directly or indirectly colluded, conspired, connived, or agreed with any bidder or anyone else to put in a sham bid, or that anyone shall refrain from bidding; that the bidder has not in any manner, directly or indirectly, sought by agreement, communication, or conference with anyone to fix the bid price of the bidder or any other bidder, or to fix any overhead, profit, or cost element of the bid price, or of that of any other bidder, or to secure any advantage against the public body awarding the contract of anyone interested in the proposed contract; that all statements contained in the bid are true; and further that the bidder has not, directly or indirectly, submitted its bid price or any breakdown thereof, or the contents thereof, or divulged information or data relative thereto, or paid, and will not pay, any fee to any corporation, partnership, company association, organization, bid depository, or to any member or agent thereof to effectuate a collusive or sham bid, and will not pay, any person or entity for such purpose.

By _____

A notary public or other officer completing this certificate verifies only the identity of the individual who signed the document to which this certificate is attached, and not the truthfulness, accuracy, or validity of that document.
--

State of California

County of _____

Signature _____

Signature of Notary Public

Subscribed and sworn to (or affirmed) before me

On this _____ day of _____, 20____,
Date Month Year

by

(1) _____

and (2) _____
Name(s) of Signer(s)

Seal
Place Notary Seal and/or Stamp Above

Proved to me on the basis of satisfactory evidence to be the person(s) who appeared before me.

DRUG-FREE WORKPLACE CERTIFICATION

CONTRACTOR/APPLICANT:

The Contractor or applicant named above hereby certifies compliance with Government Code Section 8355 in matters relating to providing a drug-free workplace. The above-named Contractor or applicant will:

1. Publish a statement notifying employees that unlawful manufacture, distribution, dispensation, possession, or use of a controlled substance is prohibited and specifying actions to be taken against employees for violations, as required by Government Code Section 8355(a)(1).
2. Establish a Drug-Free Awareness Program as required by Government Code Section 8355(a)(2), to inform employees about all of the following:
 - (a) The dangers of drug abuse in the workplace,
 - (b) The person's or organization's policy of maintaining a drug-free workplace,
 - (c) Any available counseling, rehabilitation, and employee assistance programs, and
 - (d) Penalties that may be imposed upon employees for drug abuse violations.
3. Provide as required by Government Code Section 8355(a)(3), that every employee who works on the proposed contract or loan:
 - (a) Will receive a copy of the company's drug-free policy statement, and
 - (b) Will agree to abide by the terms of the company's statement as a condition of employment on the contract or loan.

CERTIFICATION

I, the official named below, hereby swear that I am duly authorized legally to bind the Contractor or loan recipient to the above described certification. I am fully aware that this certification, executed on the date and in the county below, is made under penalty of perjury under the laws of the State of California.

OFFICIAL'S NAME:

DATE EXECUTED:

EXECUTED IN COUNTY OF:

CONTRACTOR/APPLICANT SIGNATURE:

TITLE:

**CONTRACTOR'S CERTIFICATION REGARDING WORKERS'
COMPENSATION INSURANCE**

PROJECT: WASHBURN BUE DOG PARK PROJECT

OWNER: BURNEY WATER DISTRICT

STATE OF CALIFORNIA, SHASTA COUNTY

DECLARATION:

I am aware of the provisions of Section 3700 of the Labor Code which require every employer to be insured against liability for Workers' Compensation or to undertake self-insurance in accordance with the provisions of that code, and I will comply with such provisions before commencing the performance of the work of this Contract.

Contractor: _____

Signed: _____

Date: _____

NOTICE OF AWARD

Date of Issuance:

Owner:	Burney Water District	Owner's Project No.:	306.45
Engineer:	PACE Engineering, Inc.	Engineer's Project No.:	306.45
Project:	Washburn Bue Dog Park Project		
Contract Name:	Washburn Bue Dog Park Project		
Bidder:			
Bidder's Address:			

You are notified that Owner has accepted your Bid dated **[date]** for the above Contract, and that you are the Successful Bidder and are awarded a Contract for:

[Describe Work, alternates, or sections of Work awarded]

The Contract Price of the awarded Contract is \$**[Contract Price]**. Contract Price is subject to adjustment based on the provisions of the Contract, including but not limited to those governing changes, Unit Price Work, and Work performed on a cost-plus-fee basis, as applicable.

[Number of copies sent] unexecuted counterparts of the Agreement and one copy of the Contract Documents accompany this Notice of Award or have been transmitted or made available to Bidder electronically.

Drawings will be delivered separately from the other Contract Documents.

You must comply with the following conditions precedent within 15 days of the date of receipt of this Notice of Award:

1. Deliver to Engineer **[number of copies sent]** counterparts of the Agreement, signed by Bidder (as Contractor).
2. Deliver with the signed Agreement(s) the Contract security (such as required performance and payment bonds) and insurance documentation, as specified in the Instructions to Bidders and Special Provisions.
3. Other conditions precedent (if any): **[Describe other conditions that require Successful Bidder's compliance]**

Failure to comply with these conditions within the time specified will entitle Owner to consider you in default, annul this Notice of Award, and declare your Bid security forfeited.

Within 10 days after you comply with the above conditions, Owner will return to you one fully signed counterpart of the Agreement, together with any additional copies of the Contract Documents as indicated in Section 1-4 of the Special Provisions.

Owner: Burney Water District
By (signature): _____
Name (printed): _____
Title: _____
Copy: Engineer

AGREEMENT

THIS AGREEMENT, made this ____ day of _____, 20 ____, by and between Burney Water District, hereinafter called "Owner" and _____, doing business as _____ (Insert "a corporation," "a partnership," or "an individual" as applicable), hereinafter called "Contractor."

WITNESSETH: That for and in consideration of the payments and agreements hereinafter mentioned:

1. The Contractor will commence and complete the construction of the Washburn Bue Dog Park Project ("Project"). The Work is generally described as follows:

The work consists of constructing an 18,000-square-foot fenced-in dog park in the northwest corner of the Washburn Bue Park. The dog park will have a fenced barrier to divide it into two sections and a double-gated entrance. A Conex box is currently being used for storage and will need to be relocated. A five-foot-wide paved path will be constructed from the parking area to the dog park, and a five-foot-wide decomposed granite (DG) access path will be constructed within the dog park area. Additional tables, water fountains, trash receptacles, water service, and benches will be installed as part of this Project.

2. The Contractor will furnish all of the material, supplies, tools, equipment, labor, and other services necessary for the construction and completion of the project described herein.
3. The Contractor will complete all the work in the Contract Documents within the time period shown in the Special Provisions unless the period for completion is extended otherwise by the Contract Documents. If the Contractor fails to complete this Contract, and the Project within the time fixed for completion, the Contractor shall become liable to the Owner for all loss and damage that the District may suffer on account thereof. Time is of the essence.
4. The Contractor agrees to perform all of the work described in the Contract Documents and comply with the terms therein for the lump sum of \$ _____ ("Contract Price"). The Contractor agrees to commence work and reach completion pursuant to the terms set forth in the Notice to Proceed. ("Contract Time").
5. The term "Contract Documents" means and includes the following:
 - a. Advertisement for Bids
 - b. Instructions to Bidders
 - c. Bid (Proposal)
 - d. Notice of Award
 - e. Agreement
 - f. Performance Bond
 - g. Payment Bond
 - h. General Provisions

- i. Special Provisions
 - j. Technical Specifications - included on Drawings
 - k. Any Referenced Specifications
 - l. Notice To Proceed
 - m. Contractor's Application for Payment
 - n. Certificate of Substantial Completion
 - o. Change Orders (as may be executed)
 - p. Drawings consisting of 6 sheets with each sheet bearing the following general title: Washburn Bue Dog Park Project.
 - q. Addenda (numbers __ to __, inclusive).
6. The Owner will pay to the Contractor in the manner and at such times and such amounts as set forth and required by the Contract Documents.
 7. Owner's financial obligations under this Contract shall be limited to the payment of the compensation provided in this Contract. Notwithstanding any other provision of this Contract, in no event shall Owner be liable, regardless of whether any claim is based on contract or tort, for any special, consequential, indirect, or incidental damages, including, but not limited to, lost profits or revenue or lost bonding capacity, arising out of or in connection with this Contract for the services performed in connection with this Contract.
 8. The Owner and its authorized representatives shall not in any way or manner be answerable or suffer loss, damage, expense, or liability for any loss or damage that may happen to the Work, or any part thereof, or in or about the same during its construction and before acceptance, and the Contractor shall assume all liabilities of every kind or nature arising from the Work, either by accident, negligence, theft, vandalism, or any cause whatsoever; and shall hold the Owner and its agents and authorized representatives harmless from all liability of every kind and nature arising from accident, negligence, or any cause whatsoever.
 9. The Owner has retained PACE Engineering, Inc. ("Engineer") to act as Owner's Representative, assume all duties and responsibilities of Engineer, and have rights and authority assigned to Engineer in the Contract.
 10. Neither the Contract, nor any part thereof, nor any moneys due or to become due thereunder, may be assigned by the Contractor without the prior written approval of the Owner, nor without the prior written consent of the Surety on the Contractor's Performance Bond ("Surety"), unless the Surety has waived in writing its right to notice of assignment.
 11. All terms and conditions of the Contract Documents are incorporated in this Agreement by this reference. The Contract Documents and this Agreement, set forth the entire agreement between the parties hereto and fully supersede any and all prior agreements, understandings, written or oral, between the parties hereto pertaining to the subject matter thereof.
 12. This Agreement shall be binding upon all parties hereto and their respective heirs, executors, administrators, successors, and assigns.

13. If any term, covenant, condition, or provision in any of the Contract Documents is held by a court of competent jurisdiction to be invalid, void or unenforceable, the remainder of the provisions in the Contract Documents shall remain in full force and effect and shall in no way be affected, impaired, or invalidated thereby.
14. In the event suit or action is brought by any party under this Agreement to interpret or to enforce any of the terms of this Agreement, the prevailing party shall be entitled to an award of reasonable attorney's fees and court costs to be fixed by the court having jurisdiction thereof.

IN WITNESS WHEREOF, the parties hereto have executed, or caused to be executed by their duly authorized officials, this Agreement in triplicate (three copies), each of which shall be deemed an original, on the date first above written.

OWNER:

Attest: _____

By: _____
(please type)

Name: _____

Title: _____

Name: _____

Title: _____

CONTRACTOR:

Attest: _____

By: _____
(please type)

Name: _____

Title: _____

Name: _____

Address: _____

PERFORMANCE BOND

<p>Contractor</p> <p>Name: [Full formal name of Contractor]</p> <p>Address <i>(principal place of business)</i>: [Address of Contractor's principal place of business]</p>	<p>Surety</p> <p>Name: [Full formal name of Surety]</p> <p>Address <i>(principal place of business)</i>: [Address of Surety's principal place of business]</p>
<p>Owner</p> <p>Name: Burney Water District</p> <p>Mailing address <i>(principal place of business)</i>: 20222 Hudson St. Burney, CA 96013</p>	<p>Contract</p> <p>Description <i>(name and location)</i>: Washburn Bue Dog Park Project Burney, CA</p> <p>Contract Price: [Amount from Contract]</p> <p>Effective Date of Contract: [Date from Contract]</p>
<p>Bond</p> <p>Bond Amount: [Amount]</p> <p>Date of Bond: [Date]</p> <p><i>(Date of Bond cannot be earlier than Effective Date of Contract)</i></p> <p>Modifications to this Bond form: <input type="checkbox"/> None <input type="checkbox"/> See Paragraph 16</p>	
<p>Surety and Contractor, intending to be legally bound hereby, subject to the terms set forth in this Performance Bond, do each cause this Performance Bond to be duly executed by an authorized officer, agent, or representative.</p>	
Contractor as Principal	Surety
_____ <i>(Full formal name of Contractor)</i>	_____ <i>(Full formal name of Surety) (corporate seal)</i>
By: _____ <i>(Signature)</i>	By: _____ <i>(Signature)(Attach Power of Attorney)</i>
Name: _____ <i>(Printed or typed)</i>	Name: _____ <i>(Printed or typed)</i>
Title: _____	Title: _____
Attest: _____ <i>(Signature)</i>	Attest: _____ <i>(Signature)</i>
Name: _____ <i>(Printed or typed)</i>	Name: _____ <i>(Printed or typed)</i>
Title: _____	Title: _____
<p><i>Notes: (1) Provide supplemental execution by any additional parties, such as joint venturers. (2) Any singular reference to Contractor, Surety, Owner, or other party is considered plural where applicable.</i></p>	

1. The Contractor and Surety, jointly and severally, bind themselves, their heirs, executors, administrators, successors, and assigns to the Owner for the performance of the Construction Contract, which is incorporated herein by reference.
2. If the Contractor performs the Construction Contract and any alteration thereof made as therein provided, including all contractual guarantees and warranties of materials and workmanship, and shall fully indemnify and save harmless, including for all attorneys' fees and costs the District, its trustees, officers and agents, as therein stipulated, then this obligation shall become null and void, otherwise it shall be and remain in full force and virtue.
3. If there is no Owner Default under the Construction Contract, the Surety's obligation under this Bond will arise after:
 - 3.1. The Owner first provides notice to the Contractor and the Surety that the Owner is considering declaring a Contractor Default. Such notice may indicate whether the Owner is requesting a conference among the Owner, Contractor, and Surety to discuss the Contractor's performance. If the Owner does not request a conference, the Surety may, within five (5) business days after receipt of the Owner's notice, request such a conference. If the Surety timely requests a conference, the Owner shall attend. Unless the Owner agrees otherwise, any conference requested under this Paragraph 3.1 will be held within ten (10) business days of the Surety's receipt of the Owner's notice. If the Owner, the Contractor, and the Surety agree, the Contractor shall be allowed a reasonable time to perform the Construction Contract, but such an agreement does not waive the Owner's right, if any, subsequently to declare a Contractor Default;
 - 3.2. The Owner declares a Contractor Default and notifies the Surety; and
 - 3.3. The Owner has agreed to pay the Balance of the Contract Price in accordance with the terms of the Construction Contract to the Surety or to a contractor selected to perform the Construction Contract.
4. Failure on the part of the Owner to comply with the notice requirement in Paragraph 3.1 does not constitute a failure to comply with a condition precedent to the Surety's obligations, or release the Surety from its obligations.
5. When the Owner has satisfied the conditions of Paragraph 3, the Surety shall promptly and at the Surety's expense take one of the following actions:
 - 5.1. Undertake to perform and complete the Construction Contract itself, through its agents or independent contractors;
 - 5.2. Obtain bids or negotiated proposals from qualified contractors acceptable to the Owner for a contract for performance and completion of the Construction Contract, arrange for a contract to be prepared for execution by the Owner and a contractor selected with the Owners concurrence, to be secured with performance and payment bonds executed by a qualified surety equivalent to the bonds issued on the Construction Contract, and pay to the Owner the amount of damages as described in Paragraph 7 in excess of the Balance of the Contract Price incurred by the Owner as a result of the Contractor Default; or
 - 5.3. Waive its right to perform and complete, arrange for completion, or obtain a new contractor, and with reasonable promptness under the circumstances:
 - 5.3.1 After investigation, determine the amount for which it may be liable to the Owner and, as soon as practicable after the amount is determined, make payment to the Owner; or
 - 5.3.2 Deny liability in whole or in part and notify the Owner, citing the reasons for denial.

6. If the Surety does not proceed as provided in Paragraph 5 with reasonable promptness, the Surety shall be deemed to be in default on this Bond seven days after receipt of an additional written notice from the Owner to the Surety demanding that the Surety perform its obligations under this Bond, and the Owner shall be entitled to enforce any remedy available to the Owner. If the Surety proceeds as provided in Paragraph 5.4, and the Owner refuses the payment, or the Surety has denied liability, in whole or in part, without further notice, the Owner shall be entitled to enforce any remedy available to the Owner.
7. Subject to the commitment by the Owner to pay the Balance of the Contract Price, the Surety is obligated, for:
 - 7.1. the responsibilities of the Contractor for correction of defective work and completion of the Construction Contract;
 - 7.2. additional legal, design professional, and delay costs resulting from the Contractor's Default, and resulting from the actions or failure to act of the Surety under Paragraph 5; and
 - 7.3. liquidated damages, or if no liquidated damages are specified in the Construction Contract, actual damages caused by delayed performance or non-performance of the Contractor.
8. Surety expressly agrees that the Owner may reject any contractor or subcontractor proposed by Surety to fulfill its obligations in the event of default by the Contractor. Surety shall not utilize Contractor in completing the Work nor shall Surety accept a Bid from Contractor for completion of the Work if the Owner declares the Contractor to be in default.
9. The Surety shall not be liable to the Owner or others for obligations of the Contractor that are unrelated to the Construction Contract, and the Balance of the Contract Price will not be reduced or set off on account of any such unrelated obligations. No right of action will accrue on this Bond to any person or entity other than the Owner or its heirs, executors, administrators, successors, and assigns.
10. The Surety, for value received, hereby stipulates and agrees that no change, extension of time, alteration, or addition to the terms of the Construction Contract or to the work to be performed thereunder or the specifications accompanying the same shall in any way affect its obligation on this bond, and it does hereby waive notice of any such change, extension of time, alteration, or addition to the terms of the Construction Contract or to the work or to the specifications.
11. Notice to the Surety, the Owner, or the Contractor must be mailed or delivered to the address shown on the page on which their signature appears.
12. When this Bond has been furnished to comply with a statutory or other legal requirement in the location where the construction was to be performed, any provision in this Bond conflicting with said statutory or legal requirement will be deemed deleted therefrom and provisions conforming to such statutory or other legal requirement will be deemed incorporated herein. When so furnished, the intent is that this Bond will be construed as a statutory bond and not as a common law bond.
13. Definitions
 - 13.1. *Balance of the Contract Price*—The total amount payable by the Owner to the Contractor under the Construction Contract after all proper adjustments have been made including allowance for the Contractor for any amounts received or to be received by the Owner in settlement of insurance or other claims for damages to which the Contractor is entitled, reduced by all valid and proper payments made to or on behalf of the Contractor under the Construction Contract.
 - 13.2. *Construction Contract*—The agreement between the Owner and Contractor identified on the cover page, including all Contract Documents and changes made to the agreement and the Contract Documents.

- 13.3. *Contractor Default*—Failure of the Contractor, which has not been remedied or waived, to perform or otherwise to comply with a material term of the Construction Contract.
- 13.4. *Owner Default*—Failure of the Owner, which has not been remedied or waived, to pay the Contractor as required under the Construction Contract or to perform and complete or comply with the other material terms of the Construction Contract.
- 13.5. *Contract Documents*—All the documents that comprise the agreement between the Owner and Contractor.
14. If this Bond is issued for an agreement between a contractor and subcontractor, the term Contractor in this Bond will be deemed to be Subcontractor and the term Owner will be deemed to be Contractor.
15. In the event suit is brought upon this bond by the Owner and judgment is recovered, Surety shall pay all costs incurred by the Owner in such suit, including reasonable attorney's fees to be fixed by the court.
16. Surety further agrees that death of the Contractor shall not relieve the surety of its obligations hereunder.
17. As a condition precedent to the satisfactory completion of the Contract, the above obligation shall hold good for a period equal to the warranty and/or guarantee period of the Contract, during which time Surety's obligation shall continue if Contractor shall fail to make full, complete, and satisfactory repair and replacements and totally protect the Owner from loss or damage resulting from or caused by defective materials or faulty workmanship. The obligations of Surety hereunder shall continue so long as any obligation of Contractor remains. Nothing herein shall limit the Owner's rights or the Contractor or Surety's obligations under the Contract, law or equity, including, but not limited to, California Code of Civil Procedure section 337.15
18. Modifications to this Bond are as follows: None.

PAYMENT BOND

Contractor Name: [Full formal name of Contractor] Address <i>(principal place of business)</i> : [Address of Contractor's principal place of business]	Surety Name: [Full formal name of Surety] Address <i>(principal place of business)</i> : [Address of Surety's principal place of business]
Owner Name: Burney Water District Mailing address <i>(principal place of business)</i> : 20222 Hudson St. Burney, CA 96013	Contract Description <i>(name and location)</i> : Washburn Bue Dog Park Project Burney, CA Contract Price: [Amount, from Contract] Effective Date of Contract: [Date, from Contract]
Bond Bond Amount: [Amount] Date of Bond: [Date] <i>(Date of Bond cannot be earlier than Effective Date of Contract)</i> Modifications to this Bond form: <input type="checkbox"/> None <input type="checkbox"/> See Paragraph 18	
Surety and Contractor, intending to be legally bound hereby, subject to the terms set forth in this Payment Bond, do each cause this Payment Bond to be duly executed by an authorized officer, agent, or representative.	
Contractor as Principal	Surety
_____ <i>(Full formal name of Contractor)</i>	_____ <i>(Full formal name of Surety) (corporate seal)</i>
By: _____ <i>(Signature)</i>	By: _____ <i>(Signature)(Attach Power of Attorney)</i>
Name: _____ <i>(Printed or typed)</i>	Name: _____ <i>(Printed or typed)</i>
Title: _____	Title: _____
Attest: _____ <i>(Signature)</i>	Attest: _____ <i>(Signature)</i>
Name: _____ <i>(Printed or typed)</i>	Name: _____ <i>(Printed or typed)</i>
Title: _____	Title: _____
<i>Notes: (1) Provide supplemental execution by any additional parties, such as joint venturers. (2) Any singular reference to Contractor, Surety, Owner, or other party is considered plural where applicable.</i>	

1. The Contractor and Surety, jointly and severally, bind themselves, their heirs, executors, administrators, successors, and assigns to the Owner to pay for labor, materials, and equipment furnished for use in the performance of the Construction Contract, which is incorporated herein by reference.
2. If the Contractor promptly makes payment of all sums due to Claimants, and defends, indemnifies, and holds harmless the Owner from claims, demands, liens, or suits by any person or entity seeking payment for labor, materials, or equipment furnished for use in the performance of the Construction Contract, then the Surety and the Contractor shall have no obligation under this Bond.
3. The condition of this obligation is that if the Contractor or any of its subcontractors, of the heirs, executors, administrators, successors, or assigns of any, all, or either of them shall fail to pay for any labor, materials, provisions, or other supplies, used in, upon, for or about the performance of the work contracted to be done, or for any work or labor thereon of any kind, or for amounts required to be deducted, withheld, and paid over to the Employment Development Department from the wages of employees of the Principal or any of his or its subcontractors of any tier under Section 13020 of the Unemployment Insurance Code with respect to such work or labor, than the Surety will pay the same in an amount not exceeding the amount herein above set forth.
4. In case suit is brought upon this bond, Surety will pay a reasonable attorney's fee to be awarded and fixed by the Court, and to be taxed as costs and to be included in the judgment therein rendered.
5. The Surety shall promptly and at the Surety's expense defend, indemnify, and hold harmless the Owner against a duly tendered claim, demand, lien, or suit.
6. The Surety's obligations to a Claimant under this Bond shall inure to the benefit of any and all persons, companies, and corporations entitled to file claims under section 9100 of the Civil Code, so as to give a right of action to them or their assigns in any suit brought upon this bond.
7. The Surety's total obligation will not exceed the amount of this Bond, plus the amount of reasonable attorney's fees provided hereunder, and the amount of this Bond will be credited for any payments made in good faith by the Surety.
8. Amounts owed by the Owner to the Contractor under the Construction Contract will be used for the performance of the Construction Contract and to satisfy claims, if any, under any construction performance bond. By the Contractor furnishing and the Owner accepting this Bond, they agree that all funds earned by the Contractor in the performance of the Construction Contract are dedicated to satisfying obligations of the Contractor and Surety under this Bond, subject to the Owner's priority to use the funds for the completion of the work.
9. The Surety shall not be liable to the Owner, Claimants, or others for obligations of the Contractor that are unrelated to the Construction Contract. The Owner shall not be liable for the payment of any costs or expenses of any Claimant under this Bond, and shall have under this Bond no obligation to make payments to or give notice on behalf of Claimants, or otherwise have any obligations to Claimants under this Bond.
10. The Surety hereby waives notice of any change, including changes of time, alteration, or addition to the terms of Contract Documents or to related subcontracts, purchase orders, and other obligations.
11. Notice and Claims to the Surety, the Owner, or the Contractor must be mailed or delivered to the address shown on the page on which their signature appears. Actual receipt of notice or Claims, however accomplished, will be sufficient compliance as of the date received.
12. When this Bond has been furnished to comply with a statutory or other legal requirement in the location where the construction was to be performed, any provision in this Bond conflicting with said statutory or legal requirement will be deemed deleted here from and provisions conforming to such statutory or other legal requirement will be deemed incorporated herein. When so furnished, the intent is that this Bond will be construed as a statutory bond and not as a common law bond.

13. Upon requests by any person or entity appearing to be a potential beneficiary of this Bond, the Contractor and Owner shall promptly furnish a copy of this Bond or shall permit a copy to be made.

14. Definitions

14.1. *Claim*—A written statement by the Claimant including at a minimum:

14.1.1. The name of the Claimant;

14.1.2. The name of the person for whom the labor was done, or materials or equipment furnished;

14.1.3. A copy of the agreement or purchase order pursuant to which labor, materials, or equipment was furnished for use in the performance of the Construction Contract;

14.1.4. A brief description of the labor, materials, or equipment furnished;

14.1.5. The date on which the Claimant last performed labor or last furnished materials or equipment for use in the performance of the Construction Contract;

14.1.6. The total amount earned by the Claimant for labor, materials, or equipment furnished as of the date of the Claim;

14.1.7. The total amount of previous payments received by the Claimant; and

14.1.8. The total amount due and unpaid to the Claimant for labor, materials, or equipment furnished as of the date of the Claim.

14.2. *Claimant*—An individual or entity having a direct contract with the Contractor or with a subcontractor of the Contractor to furnish labor, materials, or equipment for use in the performance of the Construction Contract. The term Claimant also includes any individual or entity that has rightfully asserted a claim under an applicable mechanic's lien or similar statute against the real property upon which the Project is located. The intent of this Bond is to include without limitation in the terms of "labor, materials, or equipment" that part of the water, gas, power, light, heat, oil, gasoline, telephone service, or rental equipment used in the Construction Contract, architectural and engineering services required for performance of the work of the Contractor and the Contractor's subcontractors, and all other items for which a mechanic's lien may be asserted in the jurisdiction where the labor, materials, or equipment were furnished.

14.3. *Construction Contract*—The agreement between the Owner and Contractor identified on the cover page, including all Contract Documents and all changes made to the agreement and the Contract Documents.

14.4. *Owner Default*—Failure of the Owner, which has not been remedied or waived, to pay the Contractor as required under the Construction Contract or to perform and complete or comply with the other material terms of the Construction Contract.

14.5. *Contract Documents*—All the documents that comprise the agreement between the Owner and Contractor.

15. If this Bond is issued for an agreement between a contractor and subcontractor, the term Contractor in this Bond will be deemed to be Subcontractor and the term Owner will be deemed to be Contractor.

16. Modifications to this Bond are as follows: None.

GENERAL PROVISIONS

The General Provisions of this construction Contract shall be by reference the General Provisions contained in the Standard Specifications for Public Works Construction, 2021 Edition, prepared by the Southern California Chapter, American Public Works Association, and Southern California Districts, Associated General Contractors of California, a joint cooperative committee, and commonly called the "Green Book."

The edition used shall be listed in the Special Provisions together with any listed addenda or supplements thereto.

NOTICE TO PROCEED

Owner: Burney Water District Owner's Project No.: 306.45
Engineer: PACE Engineering, Inc. Engineer's Project No.: 306.45
Contractor: _____ Contractor's Project No.: _____
Project: Washburn Bue Dog Park Project
Contract Name: Washburn Bue Dog Park Project
Effective Date of Contract: _____

Owner hereby notifies Contractor that the Contract Time under the above Contract will commence to run on **[date Contract Time is to start]**.

On that date, Contractor shall start performing its obligations under the Contract Documents. No Work will be done at the Site prior to such date.

In accordance with the Agreement: **[Select one of the following two alternatives, insert dates or number of days, and delete the other alternative.]**

The number of days to achieve Substantial Completion is 90 days from the date stated above for the commencement of the Contract Time, resulting in a date for Substantial Completion of **[date, calculated from commencement date above]**; and the number of days to achieve readiness for final payment is 120 days from the commencement date of the Contract Time, resulting in a date for readiness for final payment of **[date, calculated from commencement date above]**.

Before starting any Work at the Site, Contractor must comply with the following:

[Note any access limitations, security procedures, or other restrictions]

Owner: Burney Water District
By *(signature)*: _____
Name *(printed)*: _____
Title: _____
Date Issued: _____

Copy: Engineer

Contractor's Application for Payment

Owner: Burney Water District	Owner's Project No.: 306.45
Engineer: PACE Engineering, Inc.	Engineer's Project No.: _____
Contractor: _____	Contractor's Project No.: _____
Project: Washburn Bue Dog Park Project	
Contract: _____	
Application No.: _____	Application Date: _____
Application Period: From _____	to _____

1. Original Contract Price	\$	-
2. Net change by Change Orders	\$	-
3. Current Contract Price (Line 1 + Line 2)	\$	-
4. Total Work completed (Includes Materials On Hand) (Sum of Column F Lump Sum Total)	\$	-
5. Retainage		
a. 5% X \$ - Work Completed	\$	-
6. Amount eligible to date (Line 4 - Line 5.a)	\$	-
7. Less previous payments (Line 6 from prior application)		
8. Amount due this application	\$	-
9. Balance of work to finish (Line 3 - Line 4)	\$	-

Contractor's Certification

The undersigned Contractor certifies, to the best of its knowledge, the following:

(1) All previous progress payments received from Owner on account of Work done under the Contract have been applied on account to discharge Contractor's legitimate obligations incurred in connection with the Work covered by prior Applications for Payment as evidenced by the attached Unconditional Waiver and Release Upon Progress Payment, or Final Payment, as applicable. Owner may accept Conditional Waiver and Releases Upon Progress Payment or Final Payment in the form attached hereto in its discretion;

(2) Title to all Work, materials and equipment incorporated in said Work, or otherwise listed in or covered by this Application for Payment, will pass to Owner at time of payment free and clear of all liens, security interests, and encumbrances (except such as are covered by a bond acceptable to Owner indemnifying Owner against any such liens, security interest, or encumbrances); and

(3) All the Work covered by this Application for Payment is in accordance with the Contract Documents and is not defective

Contractor: _____

Signature: _____ **Date:** _____

Recommended by Engineer	Approved by Owner
By: _____	By: _____
Title: _____	Title: _____
Date: _____	Date: _____
Approved by Funding Agency	
By: _____	By: _____
Title: _____	Title: _____
Date: _____	Date: _____

UNCONDITIONAL WAIVER AND RELEASE
ON PROGRESS PAYMENT
(CIVIL CODE SECTION 8134)

NOTICE TO CLAIMANT: THIS DOCUMENT WAIVES AND RELEASES LIEN, STOP PAYMENT NOTICE, AND PAYMENT BOND RIGHTS UNCONDITIONALLY AND STATES THAT YOU HAVE BEEN PAID FOR GIVING UP THOSE RIGHTS. THIS DOCUMENT IS ENFORCEABLE AGAINST YOU IF YOU SIGN IT, EVEN IF YOU HAVE NOT BEEN PAID. IF YOU HAVE NOT BEEN PAID, USE A CONDITIONAL WAIVER AND RELEASE FORM.

Name of Claimant: _____

Name of Customer: _____

Job Location: _____

Owner: _____

Through Date: _____

Unconditional Waiver and Release

This document waives and releases lien, stop payment notice, and payment bond rights the claimant has for labor and service provided, and equipment and material delivered, to the customer on this job through the Through Date of this document. Rights based upon labor or service provided, or equipment or material delivered, pursuant to a written change order that has been fully executed by the parties prior to the date that this document is signed by the claimant, are waived and released by this document, unless listed as an Exception below. The claimant has received the following progress payment: \$ _____

Exceptions

This document does not affect any of the following:

(1) Retentions.

Extras for which the claimant has not received payment.

Contract rights, including (A) a right based on rescission, abandonment, or breach of contract, and (B) the right to recover compensation for work not compensated by the payment.

Claimant's Signature: _____

Claimant's Title: _____

Date of Signature: _____

UNCONDITIONAL WAIVER AND RELEASE
ON FINAL PAYMENT
(CIVIL CODE SECTION 8138)

NOTICE TO CLAIMANT: THIS DOCUMENT WAIVES AND RELEASES LIEN, STOP PAYMENT NOTICE, AND PAYMENT BOND RIGHTS UNCONDITIONALLY AND STATES THAT YOU HAVE BEEN PAID FOR GIVING UP THOSE RIGHTS. THIS DOCUMENT IS ENFORCEABLE AGAINST YOU IF YOU SIGN IT, EVEN IF YOU HAVE NOT BEEN PAID. IF YOU HAVE NOT BEEN PAID, USE A CONDITIONAL WAIVER AND RELEASE FORM.

Name of Claimant: _____

Name of Customer: _____

Job Location: _____

Owner: _____

Unconditional Waiver and Release

This document waives and releases lien, stop payment notice, and payment bond rights the claimant has for all labor and service provided, and equipment and material delivered, to the customer on this job. Rights based upon labor or service provided, or equipment or material delivered, pursuant to a written change order that has been fully executed by the parties prior to the date that this document is signed by the claimant, are waived and released by this document, unless listed as an Exception below. The claimant has been paid in full.

Exceptions

This document does not affect any of the following: _____

Disputed claims for extras in the amount of: \$ _____

Claimant's Signature: _____

Claimant's Title: _____

Date of Signature: _____

CONDITIONAL WAIVER AND RELEASE
ON PROGRESS PAYMENT
(CIVIL CODE SECTION 8132)

NOTICE: THIS DOCUMENT WAIVES THE CLAIMANT'S LIEN, STOP PAYMENT NOTICE, AND PAYMENT BOND RIGHTS EFFECTIVE ON RECEIPT OF PAYMENT. A PERSON SHOULD NOT RELY ON THIS DOCUMENT UNLESS SATISFIED THAT THE CLAIMANT HAS RECEIVED PAYMENT.

Name of Claimant: _____

Name of Customer: _____

Job Location: _____

Owner: _____

Through Date: _____

Conditional Waiver and Release

This document waives and releases lien, stop payment notice, and payment bond rights the claimant has for labor and service provided, and equipment and material delivered, to the customer on this job through the Through Date of this document. Rights based upon labor or service provided, or equipment or material delivered, pursuant to a written change order that has been fully executed by the parties prior to the date that this document is signed by the claimant, are waived and released by this document, unless listed as an Exception below. This document is effective only on the claimant's receipt of payment from the financial institution on which the following check is drawn:

Maker of Check: _____

Amount of Check: \$ _____

Check Payable to: _____

Exceptions

This document does not affect any of the following:

Retentions.

Extras for which the claimant has not received payment.

The following progress payments for which the claimant has previously given a conditional waiver and release but has not received payment:

Date(s) of waiver and release: _____

Amount(s) of unpaid progress payment(s): \$ _____

Contract rights, including (A) a right based on rescission, abandonment, or breach of contract, and (B) the right to recover compensation for work not compensated by the payment.

Claimant's Signature: _____

Claimant's Title: _____

Date of Signature: _____

CONDITIONAL WAIVER AND RELEASE
ON FINAL PAYMENT
(CIVIL CODE SECTION 8136)

NOTICE: THIS DOCUMENT WAIVES THE CLAIMANT'S LIEN, STOP PAYMENT NOTICE, AND PAYMENT BOND RIGHTS EFFECTIVE ON RECEIPT OF PAYMENT. A PERSON SHOULD NOT RELY ON THIS DOCUMENT UNLESS SATISFIED THAT THE CLAIMANT HAS RECEIVED PAYMENT.

Name of Claimant: _____

Name of Customer: _____

Job Location: _____

Owner: _____

Conditional Waiver and Release

This document waives and releases lien, stop payment notice, and payment bond rights the claimant has for labor and service provided, and equipment and material delivered, to the customer on this job. Rights based upon labor or service provided, or equipment or material delivered, pursuant to a written change order that has been fully executed by the parties prior to the date that this document is signed by the claimant, are waived and released by this document, unless listed as an Exception below. This document is effective only on the claimant's receipt of payment from the financial institution on which the following check is drawn:

Maker of Check:

Amount of Check: \$ _____

Check Payable to: _____

Exceptions

This document does not affect any of the following: _____

Disputed claims for extras in the amount of: \$ _____

Claimant's Signature: _____

Claimant's Title: _____

Date of Signature: _____

Progress Estimate - Lump Sum Work

Contractor's Application for Payment

Owner: _____	Owner's Project No.: _____
Engineer: PACE Engineering, Inc.	Engineer's Project No.: _____
Contractor: _____	Contractor's Project No.: _____
Project: _____	
Contract: _____	

Application No.: _____ Application Period: From _____ to _____ App Date: _____

A	B	C	D	E	F	G	H
Item No.	Description	Scheduled Value (\$)	Work Completed		Work Completed and Materials Stored to Date (D + E) (\$)	% of Scheduled Value (F / C) (%)	Balance to Finish (C - F) (\$)
			(D + E) From Previous Application (\$)	This Period (\$)			
Original Contract							
					-		-
					-		-
					-		-
					-		-
					-		-
					-		-
					-		-
					-		-
					-		-
					-		-
					-		-
					-		-
					-		-
					-		-
					-		-
					-		-
					-		-
Original Contract Totals		\$ -	\$ -	\$ -	\$ -		\$ -
Change Orders							
					-		-
					-		-
					-		-
					-		-
					-		-
Change Order Totals		\$ -	\$ -	\$ -	\$ -		\$ -
Original Contract and Change Orders							
Project Totals		\$ -	\$ -	\$ -	\$ -		\$ -

Materials on Hand Summary

Contractor's Application for Payment

Owner:	<hr/>	Owner's Project	<hr/>
Engineer:	PACE Engineering, Inc.	Engineer's Project	<hr/>
Contractor:	<hr/>	Contractor's	<hr/>
Project:	<hr/>		
Contract:	<hr/>		

Application No.:		Application	From		to	Application Date:					
A	B	C	D	E	F	G	H	I			
Item No. (Lump Sum Tab) or Bid Item No. (Unit Price Tab)	Supplier Invoice No.	Submittal No. (with Specification Section No.)	Description of Materials or Equipment Stored	Storage Location	Application No. When Materials Placed in Storage	Materials Stored					
						Previous Amount Stored (\$)	Amount Stored this Period (\$)	Amount Stored to Date (G+H) (\$)			
								-			
								-			
								-			
								-			
								-			
								-			
								-			
								-			
								-			
								-			
								-			
								-			
								-			
								-			
								-			
								-			
								-			
								-			
								-			
								-			
								-			
								-			
								-			
								-			
								-			
Totals						\$	-	\$	-	\$	-

CERTIFICATE OF SUBSTANTIAL COMPLETION

Owner:	Burney Water District	Owner's Project No.:	306.45
Engineer:	PACE Engineering, Inc.	Engineer's Project No.:	306.45
Contractor:		Contractor's Project No.:	
Project:	Washburn Bue Dog Park Project		
Contract Name:	Washburn Bue Dog Park Project		

This Preliminary Final Certificate of Substantial Completion applies to:

All Work The following specified portions of the Work:

[Describe the portion of the work for which Certificate of Substantial Completion is issued]

Date of Substantial Completion: **[Enter date, as determined by Engineer]**

The Work to which this Certificate applies has been inspected by authorized representatives of Owner, Contractor, and Engineer, and found to be substantially complete. The Date of Substantial Completion of the Work or portion thereof designated above is hereby established, subject to the provisions of the Contract pertaining to Substantial Completion. The date of Substantial Completion in the final Certificate of Substantial Completion marks the commencement of the contractual correction period and applicable warranties required by the Contract.

A punch list of items to be completed or corrected is attached to this Certificate. This list may not be all-inclusive, and the failure to include any items on such list does not alter the responsibility of the Contractor to complete all Work in accordance with the Contract Documents. Warranties shall not commence on punch list work not yet completed or defective work until such work is completed and corrected, as applicable.

Amendments of contractual responsibilities recorded in this Certificate should be the product of mutual agreement of Owner and Contractor.

The responsibilities between Owner and Contractor for security, operation, safety, maintenance, heat, utilities, insurance, and warranties upon Owner's use or occupancy of the Work must be as provided in the Contract, except as amended as follows:

Amendments to Owner's Responsibilities: None As follows:

[List amendments to Owner's Responsibilities]

Amendments to Contractor's Responsibilities: None As follows:

[List amendments to Contractor's Responsibilities]

The following documents are attached to and made a part of this Certificate:

[List attachments such as punch list; other documents]

This Certificate does not constitute an acceptance of Work not in accordance with the Contract Documents, nor is it a release of Contractor's obligation to complete the Work in accordance with the Contract Documents.

Engineer

By *(signature)*: _____

Name *(printed)*: _____

Title: _____

WORK CHANGE DIRECTIVE NO.: _____

Owner: Burney Water District
Engineer: PACE Engineering, Inc.
Contractor:
Project: Washburn Bue Dog Park Project
Contract Name: Washburn Bue Dog Park Project
Date Issued: Effective Date of Work Change Directive:
Owner's Project No.:
Engineer's Project No.: 306.45
Contractor's Project No.: 306.45

Contractor is directed to proceed promptly with the following change(s):

Description:

[Description of the change to the Work]

Attachments:

[List documents related to the change to the Work]

Purpose for the Work Change Directive:

[Describe the purpose for the change to the Work]

Directive to proceed promptly with the Work described herein, prior to agreeing to change in Contract Price and Contract Time, is issued due to:

Notes to User—Check one or both of the following

Non-agreement on pricing of proposed change. Necessity to proceed for schedule or other reasons.

Estimated Change in Contract Price and Contract Times (non-binding, preliminary):

Contract Price: \$ _____ **[increase] [decrease] [not yet estimated].**

Contract Time: _____ days **[increase] [decrease] [not yet estimated].**

Basis of estimated change in Contract Price:

Lump Sum Unit Price Cost of the Work Other

Recommended by Engineer

Authorized by Owner

By: _____

Title: _____

Date: _____

CHANGE ORDER NO.:__

Owner: Burney Water District	Owner's Project No.: 306.45
Engineer: PACE Engineering, Inc.	Engineer's Project No.: 306.45
Contractor:	Contractor's Project No.:
Project: Washburn Bue Dog Park Project	
Contract Name: Washburn Bue Dog Park Project	
Date Issued:	Effective Date of Change Order:

The Contract is modified as follows upon execution of this Change Order:

Description:

[Description of the change]

Attachments:

[List documents related to the change]

Change in Contract Price	Change in Contract Times [State Contract Times as either a specific date or a number of days]
Original Contract Price: \$ _____	Original Contract Times: Substantial Completion: _____ Ready for final payment: _____
[Increase] [Decrease] from previously approved Change Orders No. 1 to No. [Number of previous Change Order] : \$ _____	[Increase] [Decrease] from previously approved Change Orders No.1 to No. [Number of previous Change Order] : Substantial Completion: _____ Ready for final payment: _____
Contract Price prior to this Change Order: \$ _____	Contract Times prior to this Change Order: Substantial Completion: _____ Ready for final payment: _____
[Increase] [Decrease] this Change Order: \$ _____	[Increase] [Decrease] this Change Order: Substantial Completion: _____ Ready for final payment: _____
Contract Price incorporating this Change Order: \$ _____	Contract Times with all approved Change Orders: Substantial Completion: _____ Ready for final payment: _____

The undersigned Contractor approves the foregoing as to the changes, if any, to the Contract Price specified for each item, and as to the extension of time allowed, if any, for completion of the entire work as stated therein, and agrees to furnish all labor, materials, and services and perform all work necessary to complete any additional work specified for the consideration stated therein. Submission of sums which have no basis in fact or which Contractor knows are false are at the sole risk of Contractor and may be a violation of the False Claims Act set forth under Government Code section 12650, et seq.

This change order does not operate to modify the Contract Documents until approved by the governing board of this District and signed by the District. Until such time as this change order is approved by the District's governing board and executed by a duly authorized District representative, this change order is not effective and not binding.

It is expressly understood that the compensation and time, if any, granted herein represent a full accord and satisfaction for any and all time and cost impacts of the items herein, and Contractor waives any and all further compensation, related damages (whether actual or consequential), or time extension based on the items herein. The value of the extra work or changes expressly includes any and all of the Contractor's costs and expenses, both direct and indirect, resulting from additional time required on the Project or resulting from delay to the Project. Contractor expressly waives any costs, expenses, damages, or time extensions not included in this change order. Contractor is not entitled to separately recover amounts for overhead or other indirect costs.

RECOMMENDED:

ACCEPTED:

ACCEPTED:

By: _____ By: _____ By: _____
 Engineer (if required) Owner (Authorized Signature) Contractor (Authorized Signature)
Title: _____ Title: _____ Title: _____
Date: _____ Date: _____ Date: _____

Approved by Funding Agency (if applicable)

By: _____ Date: _____
Title: _____

SPECIAL PROVISIONS
PART 1
MODIFICATIONS TO INSTRUCTIONS TO BIDDERS
AND GENERAL PROVISIONS

1-1	CONTRACT DOCUMENTS	SP-1
1-2	OWNER, AGENCY, OR BOARD	SP-1
1-3	ENGINEER.....	SP-1
1-4	CONTRACT DOCUMENTS FURNISHED TO CONTRACTOR	SP-1
1-5	CONTRACTOR'S MARKUP	SP-1
1-6	TIME OF COMPLETION AND ORDER OF WORK.....	SP-2
1-7	SCHEDULE.....	SP-2
1-8	LIQUIDATED DAMAGES.....	SP-2
1-9	SITE INVESTIGATION AND REPRESENTATION.....	SP-2
1-10	SUBSURFACE DATA	SP-3
1-11	EXCAVATIONS.....	SP-3
1-12	ENVIRONMENTAL REQUIREMENTS	SP-3
1-13	ENCROACHMENT PERMITS	SP-6
1-14	STORM WATER POLLUTION PREVENTION PLAN (SWPPP)	SP-6
1-15	UTILITY LOCATIONS	SP-7
1-16	MAJOR PUBLIC UTILITIES SERVING THE AREA OF WORK	SP-8
1-17	LIABILITY AND WORKERS' COMPENSATION INSURANCE	SP-8
1-18	BUILDER'S RISK "ALL-RISK" INSURANCE	SP-9
1-19	INDEMNITY.....	SP-9
1-20	CLAIMS DISPUTE RESOLUTION.....	SP-9
1-21	ATTORNEY'S FEES	SP-9
1-22	TRAFFIC CONTROL, ACCESS, AND PUBLIC CONVENIENCE	SP-9
1-23	SAFETY	SP-10
1-24	ACCESS BY FEDERAL, STATE AND LOCAL GOVERNMENT OFFICIALS	SP-11
1-25	PRE-CONSTRUCTION CONFERENCE	SP-11
1-26	LAYOUT OF WORK AND SURVEYING.....	SP-11
1-27	PROTECTION OF WORK AND MATERIALS	SP-11
1-28	SUBSTITUTION OF MATERIALS AND EQUIPMENT	SP-11
1-29	PLAN REVISIONS FOR CONTRACTOR'S PROPOSALS OF SUBSTITUTIONS.....	SP-12
1-30	LUMP-SUM PRICE BREAKDOWN	SP-12
1-31	COMPLIANCE WITH STATE SAFETY, OSHA, AND OTHER CODE REQUIREMENTS ...	SP-13
1-32	WATER, SANITATION, POWER, AND TELEPHONE	SP-13
1-33	COORDINATION	SP-13
1-34	EQUIPMENT INFORMATION.....	SP-13
1-35	FORMAT OF TECHNICAL SPECIFICATIONS	SP-14
1-36	SALVAGE OF MATERIALS AND EQUIPMENT.....	SP-14

1-37	OFF-SITE DISPOSAL OF MATERIALS	SP-15
1-38	CONSTRUCTION OBSERVER	SP-15
1-39	SUSPENSION OF WORK	SP-15
1-40	COMPETENT WORKERS	SP-15
1-41	WORKING HOURS.....	SP-15
1-42	LABOR CODE REQUIREMENTS.....	SP-16
1-43	AUTHORITY OF ENGINEER.....	SP-17
1-44	MEASUREMENT AND PAYMENT	SP-17
1-45	FIRE PREVENTION.....	SP-20
1-46	AUTHORITY TO PROVIDE A SERVICE	SP-20
1-47	PRECEDENCE OF CONTRACT DOCUMENTS.....	SP-20
	RELEASE OF CLAIMS.....	SP-21

SPECIAL PROVISIONS
PART 1
MODIFICATIONS TO INSTRUCTIONS TO BIDDERS
AND GENERAL PROVISIONS

1-1 CONTRACT DOCUMENTS

The Contract Documents include all items listed in the form of Agreement. The document hereinafter referred to as the "Standard Specifications," or simply as "SS," is the separately bound 2021 Edition of Standard Specifications for Public Works Construction, commonly called the "Green Book." The entire Part 1 - General Provisions of the Standard Specifications as modified and added to herein by these Special Provisions are part of these Contract Documents. Portions of Parts 2, 3, and 4 of the Standard Specifications shall be included as part of these Contract Documents when referenced herein.

Where other reference specifications such as those of ASTM, AASHTO, etc., have been referred to, the applicable portion of such specifications shall become a part of these Contract Documents.

The words "State Specifications" when used in these Specifications shall mean the Standard Specifications of the State of California, Department of Transportation (Caltrans), 2018 edition.

1-2 OWNER, AGENCY, OR BOARD

Wherever the term "Owner," "Agency," "District," or "Board" is used in these Contract Documents, it shall be understood to mean Burney Water District.

1-3 ENGINEER

Wherever the term "Engineer" is used in these Contract Documents, it shall be understood to mean PACE Engineering, Inc., or its authorized representative.

1-4 CONTRACT DOCUMENTS FURNISHED TO CONTRACTOR

The Engineer will furnish to the Contractor, upon request and free of charge, two (2) copies of Contract Documents, complete with full-sized sets of Drawings. Additional copies of Contract Documents or Drawings will be the responsibility of the Contractor to obtain.

1-5 CONTRACTOR'S MARKUP

Refer to SS 7-4.3 regarding Contractor's allowable markup on extra work. Delete paragraphs 7-4.3.1 and 7-4.3.2 and substitute the following:

7-4.3.1 **Work by Contractor.** The following percentages shall be added to the Contractor's costs and shall constitute the markup for all overhead and profits:

- (1) Labor 15
- (2) Materials 15
- (3) Equipment Rental 15

To the sum of the costs and markups provided for in this subsection, 1 percent shall be added as compensation for bonding.

7-4.3.2 **Work by Subcontractor.** When all or any part of the extra work is performed by a Subcontractor, the markup established above "Work by Contractor," shall be applied to the Subcontractor's actual cost of such work. A markup of 5 percent of the subcontracted portion of the extra work may be added by the Contractor.

1-6 TIME OF COMPLETION AND ORDER OF WORK

Refer to SS 6-3. The time of completion shall be specified in calendar days.

Refer to SS 6-4.1. Delete the reference to "adverse weather or elements necessitating cessation of work" in the fifth line of the first paragraph. Also delete Section 6-3.2, Contract Time Accounting.

All work as set forth in these Contract Documents shall be diligently prosecuted and substantially completed within 90 calendar days from the date of issuance of the Notice to Proceed and completed and ready for final payment within 120 days from the date of issuance of the Notice to Proceed.

No extension of time will be considered for weather conditions normal to the area in which the work is being performed. Unusual weather conditions, if determined by the Engineer to be of a severity that would stop the normal progress of work that could normally be accomplished in that time period, may be considered as cause for an extension of Contract completion time.

In the event there is a change in local, state, or federal law or regulation associated with the service being provided, this will constitute a change in conditions and will result in renegotiations of this Contract.

1-7 NONDISCRIMINATION

Contractor herein agrees not to discriminate in its recruiting, hiring, promotion, demotion, or termination practices on the basis of race, religious creed, color, national origin, ancestry, physical disability, mental disability, medical condition, genetic information, marital status, sex, gender, gender identity, gender expression, age, sexual orientation, or military or veteran status in the performance of this Contract and to comply with the provisions of the California Fair Employment and Housing Act as set forth in part 2.8 of division 3 of the California Government Code, commencing at section 12900; the Federal Civil Rights Act of 1964, as set forth in Public Law 88-352, and all amendments thereto; Executive Order 11246, and all administrative rules and regulations found to be applicable to Contractor and Subcontractor.

1-8 SCHEDULE

Prior to start of any work, the Contractor shall submit its proposed construction schedule to the Engineer for approval. The schedule shall include a plan for coordinating each construction site visit between the Owner and/or Engineer and Contractor.

1-9 LIQUIDATED DAMAGES

The amount of liquidated damages specified in SS 6-9 shall be changed to \$1,000 per calendar day as may be imposed administratively by the State Board or a regional board pursuant to Article 2.5 (commencing with Section 13323) of Chapter 5, per Section 13268(b)(1) of the Porter-Cologne Water Quality Act.

1-10 SITE INVESTIGATION AND REPRESENTATION

The Contractor acknowledges that it has satisfied itself as to the nature and location of the work, the general and local conditions, particularly those bearing upon availability of transportation, disposal, handling and storage of materials, availability of labor, water, electric power, roads, and uncertainties of weather, drainage courses, or similar physical conditions at the site, the conformation and conditions of the ground, the character of equipment and facilities needed preliminary to and during the execution of the work, and all other matters that can in any way affect the work or the cost thereof under this Contract.

The Contractor further acknowledges that it has satisfied itself as to the character, quality, and quantity of surface and subsurface materials to be encountered from inspecting the site, review of information made available by the Engineer and Owner, as well as from information presented by the Drawings and Specifications made a part of this Contract. Any failure by the Contractor to acquaint itself with all the available information will not relieve it from responsibility for properly estimating the difficulty or cost of successfully performing the work.

1-11 SUBSURFACE DATA

No test holes have been dug. The Contractor shall examine the site and make its own investigation.

1-12 EXCAVATIONS

Refer to SS 5-7 Safety regarding shoring plan submittal requirements.

In addition, the following procedures shall be followed in connection with any excavations:

- (1) The Contractor shall promptly, and before the following conditions are disturbed, notify the Owner in writing, of any:
 - (a) Material that the Contractor believes may be material that is hazardous waste, as defined in Section 25117 of the California Health and Safety Code that is required to be removed to a Class I, Class II, or Class III disposal site in accordance with provision of existing Federal, State, and local law.
 - (b) Subsurface or latent physical conditions at the site differing from those indicated.
 - (c) Unknown physical conditions at the site of any unusual nature, different materially from those ordinarily encountered and generally recognized as inherent in work of the character provided for in the contract.
- (2) The Owner shall promptly investigate the conditions, and if it finds that the conditions do involve hazardous waste, and cause a decrease or increase in the Contractor's cost of, or the time required for, performance of any part of the work shall issue a change order under the procedures described in the Contract.
- (3) In the event that a dispute arises between the Owner and the Contractor whether the conditions involve hazardous waste, or cause a decrease or increase in the Contractor's cost of, or time required for, performance of any part of the work, the Contractor shall not be excused from any scheduled completion date provided for by the Contract, but shall proceed with all work to be performed under the Contract. The Contractor shall retain any and all rights provided either by Contract or by law, which pertain to the resolution of disputes and protests between the contracting parties.

1-13 ENVIRONMENTAL REQUIREMENTS

When constructing a project involving trenching and/or other related earth excavations, Contractor shall comply with the following environmental conditions:

- A. *Wetlands* - When disposing of excess, spoil, or other construction materials on public or private property, Contractor shall not fill in or otherwise convert wetlands.

- B. *Floodplains* - When disposing of excess, spoil, or other construction materials on public or private property, Contractor shall not fill in or otherwise convert 100-year floodplain areas delineated on the latest Federal Emergency Management Agency Floodplain maps, or other appropriate maps, i.e., alluvial soils on NRCS Soil Survey maps.
- C. *Historic Preservation* - Any excavation by Contractor that uncovers a historical or archaeological artifact shall be immediately reported to Engineer who will contact a representative of California State Parks. Construction shall be temporarily halted pending the notification process and further direction issued by California State Parks after consultation with the State Historic Preservation Officer (SHPO).
- D. *Endangered Species* - Contractor shall comply with the Endangered Species Act, which provides for protection of endangered and/or threatened species and critical habitat. Should any evidence of the presence of endangered and/or threatened species or their critical habitat be brought to the attention of Contractor, Contractor will immediately report this evidence to Engineer, who will contact a representative of California State Parks. Construction shall be temporarily halted pending notification process and further directions issued by California State Parks after consultation with the U.S. Fish and Wildlife Service.
- E. *Mitigation Measures* - The following environmental mitigation measures are required on this Project:
 - 1. Dust Control
 - a. Where dust is created, either by vehicles of the Contractor or others through work being done by the Contractor, such dust shall be controlled by the Contractor through watering or by cleaning up the material causing the dust. Dust control shall be continued as necessary until the work is accepted by the Owner.
 - b. Apply nontoxic soil stabilizers according to manufacturers' specification to all graded and/or trenched areas that sit inactive for ten days or more.
 - c. Reestablish ground cover on previously vegetated areas disturbed by project-related activities through seeding, revegetating, and watering as appropriate.
 - d. Suspend trenching and/or grading activities when winds (as instantaneous gusts) exceed 15 miles per hour or when winds create construction-induced visible dust plumes moving beyond the project site, in spite of dust control measures.
 - e. Provide temporary traffic control as appropriate during all phases of construction to improve traffic flow.
 - f. Water active construction sites as appropriate to reduce dust.
 - g. All trucks hauling dirt, sand, soil, or other loose materials should be covered or maintain at least two feet of freeboard (i.e., minimum vertical distance between the top of the load and the trailer).
 - h. Sweep streets at the end of the day if visible soil materials are carried onto adjacent public paved roads (recommend water sweeper with reclaimed water).

2. Bird Nesting Survey

If proposed site disturbance and construction activities are planned to occur within the project area during the nesting season for local avian species (typically February 1 through August 31), the Contractor shall retain qualified personnel to conduct a focused survey for active nests of special-status birds within and in the vicinity of (up to 200 feet and no less than 100 feet outside project boundaries, where possible) the disturbance and construction area no more than 30 days prior to ground disturbance or tree removal. If active nests are found, trees/shrubs with nesting birds shall not be disturbed until abandoned by the birds or qualified personnel deem disturbance potential to be minimal (in consultation with the USFWS and/or CDFG, where appropriate). Tree removal shall be restricted to a period following fledging of chicks, which typically occurs between late July and early August.

If an active nest is located within the 100 feet (200 feet for raptors) of construction activities, other restrictions may include establishment of exclusion zones (no ingress of personnel or equipment at a minimum radius of 100 feet or 200 feet, as appropriate, around the nest as confirmed by the appropriate resource agency) or alteration of the construction schedule.

If construction activities or tree removal are proposed to occur during the non-breeding season (September 1 through January 31), a survey is not required, no further studies are necessary, and no mitigation is required.

3. Cultural Resources

If, during the course of project implementation, cultural resources (i.e., prehistoric sites, historic features, isolated artifacts, and features such as concentrations of shell or glass) are discovered, work shall be halted immediately within 50 feet of the discovery, the Contractor shall notify the Engineer. A professional archaeologist that meets the Secretary of the Interior's Professional Qualifications Standards in prehistoric or historical archaeology shall be retained by the Owner to determine the significance of the discovery. The Owner shall consider mitigation recommendations presented by a professional archaeologist and implement a measure or measures that the Owner deems feasible and appropriate. Such measures may include avoidance, preservation in place, excavation, documentation, curation, data recovery, or other appropriate measures.

If, during the course of project implementation, paleontological resources (e.g., fossils) are discovered, work shall be halted immediately within 50 feet of the discovery, the Engineer shall be immediately notified. A qualified paleontologist shall be retained by the Owner to determine the significance of the discovery. The Owner shall consider the mitigation recommendations presented by a professional paleontologist and implement a measure or measures that the Owner deems feasible and appropriate. Such measures may include avoidance, preservation in place, excavation, documentation, curation, data recovery, or other appropriate measures.

If, during the course of project implementation, human remains are discovered, all work shall be halted immediately within 50 feet of the discovery, the Engineer shall be immediately notified, and the County Coroner must be notified, according to Section 5097.98 of the California Public Resources Code and Section 7050.5 of the California Health and Safety Code. If the remains are determined to be Native American, the coroner will notify the Native American Heritage Commission, and the procedures outlined in California Code of Regulations Section 15064.5(d) and (e) shall be followed.

4. Noise

The Contractor shall provide documentation to the Engineer that all construction equipment is regularly maintained. Additionally, all equipment utilized for construction of all phases of the project shall include the following noise reduction devices:

- a. All vehicles and engines shall be equipped with the appropriate manufacturer's noise reduction device(s), including, but not limited to, a manufacturer's muffler (or equivalently rated material) that is free of rust, holes, and exhaust leaks.
- b. All engine housing doors shall be kept closed and noise-insulating material shall be mounted on the engine housing to reduce noise, to the extent practical without interfering with the manufacturer's guidelines for engine operation or exhaust.
- c. Portable compressors, generators, pumps, and other such devices shall be covered with noise-insulating fabric to the extent practical without interfering with the manufacturer's guidelines for engine operation or exhaust, and shall further reduce noise by operating such devices at lower engine speeds during work to the maximum extent possible.
- d. Construction equipment not actively being utilized shall be turned off.
- e. Vehicle idling on-site shall be limited to 5 minutes.
- f. Reduced volume back-up alarms shall be used for all construction vehicles when practicable.

1-14 ENCROACHMENT PERMITS

The Contractor shall confine its operations to Owner property, road rights-of-way, and existing easements.

1-15 STORM WATER POLLUTION PREVENTION PLAN (SWPPP)

A Storm Water Pollution Prevention Plan is not required because the area of disturbance is estimated to be less than one acre. However, before beginning work, the Contractor shall submit an erosion control plan (ECP) for review by the Engineer. The ECP shall utilize best management practice (BMP) guidelines set forth in Section 3 – Erosion and Sediment Control BMPs of the *Storm Water Management Practices Handbook Portal: Construction*.

The Contractor shall address, at a minimum, the following items:

1. Layout, location, and schedule of implementation for erosion control facilities.
 - a. Minimize ground disturbance activities to those areas immediately planned for construction.
 - b. Identification and use of best management practices.
 - c. All exposed stockpiles shall be covered, watered, or treated with soil stabilization material as necessary to prevent wind erosion.
 - d. During wet weather periods, stockpiles shall be covered or sediment traps built around the stockpile to prevent erosion into off-site water courses or storm drains.
 - e. All hazardous materials shall be stored in covered facilities and in properly labeled containers. Any spills shall be immediately cleaned up.
 - f. All equipment shall be properly maintained to prevent leakage of oil, fuel, or other fluids. Drip pans shall be used under leaking equipment that is stationary or idle.
 - g. Contractor shall obtain approval of all permits and Drawings prior to commencing construction activities. The area of potential disturbance has been determined to be

less than one acre and is therefore exempt from obtaining a Storm Water Pollution Prevention Plan (SWPPP). If the Contractor causes the disturbed area to increase to greater than or equal to one (1) acre through its means and methods, then it shall prepare and implement a SWPPP at no extra cost to Owner.

2. Provide, maintain, and operate temporary facilities to control erosion and sediment releases, and to protect work and existing facilities from flooding throughout construction period.
3. Design erosion and sediment controls to handle peak runoff resulting from 25-year, 24-hour storm event based on U.S. Weather Bureau, "Rainfall-Frequency Atlas of the United States for Durations from 30 minutes to 24 hours and Return Periods from 1 to 100 Years," Technical Paper No. 40, 1981.
4. During wet weather periods, no cleaning or grading shall occur in excess of that which can be surfaced stabilized at the end of each workday, or which otherwise endanger the public health and safety or is otherwise prohibited by state and federal regulations.
5. During wet weather periods, October 15 to May 15, all erosion control measures shall be in place unless otherwise directed by the Engineer.

1-16 UTILITY LOCATIONS

Refer to SS 402-1. The location of main line utilities shown on the Drawings (excluding services to each property) is a compilation of records and/or field locations by the various responsible agencies, together with obvious utilities which have been survey located. Many of the records used may be incomplete or inaccurate; consequently, the Contractor should be aware that the location, amount, and extent of utilities shown on the Drawings may be considerably different from what exists. Extreme care will be necessary during excavation not to disturb existing utilities. Utilities, which should not be encountered or are not expected to restrict the Contractor's operations, have not been shown.

The new Washburn Bue Dog Park shall be constructed in such a manner as to maintain the minimum cover requirements and utility clearance requirements as shown on the Drawings. The Contractor shall (pothole) locate and expose the existing utilities to be encountered, including water services and sewer laterals if marked by the utility, sufficiently in advance of the normal pipeline excavation to allow for field changes in the alignment of the pipeline. Unless otherwise approved by the Engineer, potholing shall be accomplished at least two (2) working days before the main excavation occurs at the existing utility. No extra payment will be due to the Contractor for alignment changes (either vertical or horizontal) as may be required to clear existing utilities, unless it can be shown that such utilities have been shown or marked at incorrect locations and their actual location necessitates an increase in the scope of work. Protection of utilities, which have been identified on the Drawings and in the Specifications and correctly marked by the utility operator in the field prior to construction when required by law, will be considered to be in the normal scope of work (not extra work). The Contractor is not responsible, pursuant to California Government Code 4216, for "subsurface installations" that are not found within 2 feet horizontally of either side of the exterior surface of the utility as marked by the utility operator, but the Contractor shall immediately notify the Engineer and Owner of such a condition.

The Engineer's field representative shall be notified immediately of any utilities encountered so that an accurate record of their existence may be prepared and so that verification or need for alignment changes may be considered.

Any utilities encountered, including storm drain pipes, shall be maintained, or repaired if damaged, unless the Contractor can reasonably determine that such utilities have been previously abandoned. Repair methods and materials shall be approved by the agency responsible for maintenance of the utility.

1-17 MAJOR PUBLIC UTILITIES SERVING THE AREA OF WORK

Following is a list of the major public utilities serving the area. The list indicates the name and telephone number of the various utilities that are known to have facilities near the project. The Contractor shall notify USA (811) for subsurface utility locations at least two working days, not including date of notification, prior to commencing excavations for this project.

<u>Name</u>	<u>Telephone No.</u>
Burney Water District	(530) 335-3582
PG&E, Frontier Communications, and Zito Media	(800) 227-2600

1-18 LIABILITY AND WORKERS' COMPENSATION INSURANCE

Refer to SS 5-4.

The Owner, the Engineer, State of California, and consultants, and each of their officers, agents, and employees, shall be specifically named as additional insureds on separate endorsements of the Contractor's comprehensive general liability policy with a waiver of subrogation against such additional insureds. The cancellation clause shall have the following word and phrase struck out: **"endeavor"** and **"but failure to do so shall impose no obligation or liability of any kind upon the insurer, its agents or representatives."**

The Contractor shall obtain and maintain continuously, General Public Liability and Property Damage Insurance coverage (including vehicle coverage) issued to the Contractor and protecting the Contractor from all claims for personal injury, including death, and all claims for destruction of or damage to property, arising out of or in connection with any operations under the Contract Documents, whether such operations be by the Contractor or by any subcontractor employed by the Contractor or anyone directly or indirectly employed by any of them, or by anyone for whose acts any of them may be liable.

The limits of liability insurance shown in SS 5-4 shall be modified to provide coverage for not less than the following amounts or greater, where required by Laws and Regulations:

1. Workers' Compensation and related coverages:
 - a. Employer's Liability: \$1,000,000 per occurrence
2. Contractor's General Liability shall include completed operations and product liability coverages and eliminate the exclusion with respect to property under the care, custody, and control of the Contractor:
 - a. Each Occurrence (Bodily Injury and Property Damage): \$1,000,000
 - b. Personal and Advertising Injury: \$1,000,000
 - c. General Aggregate: \$2,000,000
 - d. Products – Completed Operations Aggregate: \$2,000,000
 - e. Property Damage liability insurance shall provide Explosion, Collapse, and Underground coverages where applicable.
 - f. Excess or Umbrella Liability:
 - i. Each Occurrence: \$1,000,000
 - ii. General Aggregate: \$1,000,000
3. Automobile Liability:
 - a. Combined Single Limit of \$1,000,000.

Coverage for Commercial General Liability (CGL) shall be at least as broad as Insurance Service Office (ISO) "occurrence form CG 00011093, 1993 Edition," and for Automobile Liability shall be at least as broad as ISO "form number CA 0001, ed. 1/87, code 1." AM Best's rating of no less than A:VII or equivalent, as determined by the Owner. Contractor shall include all subcontractors as insured.

Certificates of insurance indicating the above coverage shall be furnished to the Owner along with the executed Agreement and bonds.

1-19 BUILDER'S RISK "ALL-RISK" INSURANCE

The Contractor will not be required to purchase an "All-Risk" insurance policy for this project. However, the Contractor shall be responsible for protection of the work, until project acceptance, or until beneficial use is obtained by the Owner, whichever is sooner, and shall make any necessary repairs to such facilities as may be caused by flood, wind, landslide, collapse, earthquakes, or the results of faulty workmanship, except as may be caused by "Acts of God" resulting in damage in excess of five percent of the Contract Amount, as defined in Section 7105 of the Public Contract Code. The Contractor may want to purchase an "All-Risk," or other type of policy, to protect the Contractor from such loss.

1-20 INDEMNITY

The Contractor shall defend, hold harmless, and indemnify Owner, Engineer, Shasta County, State of California, consultants, and each of their officers, agents, and employees from and against all claims (including but not limited to claims of Contractor's agents and employees), liability, losses, damages, and expenses arising or alleged to arise from or during the performance of the work under this Agreement, except those losses and damages found to be caused by the sole negligence or willful misconduct of the party indemnified hereunder.

1-21 CLAIMS DISPUTE RESOLUTION

Pursuant to modifications to the Public Contract Code Article 1.5 Section 20104, the Contractor and Owner shall resolve all construction claims of less than \$375,000 in accordance with these statutes, unless the Owner decides pursuant to Public Contract Code 20104(a) (2) to use arbitration as referenced, commencing with Section 10240. In summary, these statutes require such claims to be presented and responded to within prescribed deadlines, require a "meet and confer conference" when demanded, followed by a non-binding mediation process, followed by judicial arbitration if still unresolved.

1-22 ATTORNEY'S FEES

Should any litigation, arbitration, or mediation be commenced between the parties to this contract, concerning the contract, any interpretation thereof, or the rights or duties of a party in relation thereto, the party prevailing in such action shall be entitled, in addition to such other relief as may be granted, to recover its court costs and attorney's fees as may be determined in such action.

1-23 TRAFFIC CONTROL, ACCESS, AND PUBLIC CONVENIENCE

Refer to SS 600 Access and SS 601 Temporary Traffic Control.

The Contractor shall thoroughly inspect the roadway surface over which its equipment will move and attempt to schedule only that equipment which will not cause damage to existing roadways. If it is necessary to use equipment that damages the roadway the Contractor shall be liable for

this damage regardless of whether the road meets current design standards, or whether loads by said equipment are allowable. The intent is that the Contractor be responsible for any damage caused by this project. Repair made necessary from non-compliance shall be as directed by the Engineer with the intent that repairs such as patching, grading, etc., shall result in a road surface at least equal to that on adjacent roadway. Appearance of the area shall weigh heavily in determining the extent of repair to be ordered. Cost of repairs shall be borne entirely by the Contractor.

When in roadways, excavated material shall be removed from the work area concurrently with the operation. All material removed from the site shall be the property of the Contractor. Payment for the removal and disposal of all material shall be considered as included in the most applicable unit price bid for this work, and no additional compensation will be allowed therefore.

The Contractor shall maintain all drainage ways encountered in such a fashion that they will always be ready to accept storm flows. Drainage way interruption will not be allowed during periods of imminent storm flows. Interruptions may occur if it appears planned operations will be completed and the drainage way made serviceable before storm flows appear imminent.

The Contractor shall normally maintain a minimum one-way traffic access on all roadways at all times. At the end of each working day the Contractor's operations shall be left such that two-way traffic shall be maintained. Flagmen shall be used at each end of the work area at any time two-way traffic is not being maintained.

The Contractor shall provide for safe, continuous, and uninterrupted pedestrian and vehicular access to each residence and commercial establishment adjacent to the work. The convenience of the general public and residents and the protection of persons and property are of prime importance and shall be provided for in an adequate and satisfactory manner. The Contractor shall keep the residents informed of its proposed work schedule in such a manner that residences will have adequate notice to move their vehicles if access to their dwelling will be temporarily interrupted. Any deviation from this requirement must have prior authorization from the Engineer.

1-24 SAFETY

Refer to SS 5-7 Safety.

The Contractor shall be solely and completely responsible for conditions of the job site, including safety of all persons (including employees) and property during performance of the work. This requirement will apply continuously and not be limited to normal working hours.

Safety provisions shall conform to all applicable Federal, State, County, and local laws, ordinances, and to other rules of law applicable to the work.

The Contractor shall maintain at its office or other well-known place at the job site, all articles necessary for giving first aid to the injured, and shall establish the procedure for the immediate removal to a hospital or a doctor's care of persons (including employees) who may be injured on the job site.

The Duty of the Engineer to conduct construction review of the Contractor's performance is not intended to include review of the adequacy of the Contractor's safety measures in, on, or near the construction site.

If death or serious injuries or serious damages are caused, the accident shall be reported immediately by telephone or messenger to both the Engineer and the Owner. In addition, the Contractor must promptly report in writing to the Engineer all accidents whatsoever arising out of, or in connection with, the performance of the work whether on, or adjacent to the site, giving full details and statements of witnesses.

1-25 ACCESS BY FEDERAL, STATE AND LOCAL GOVERNMENT OFFICIALS

Authorized representatives of federal, state, and local government officials shall at all times have access to the work wherever it is in preparation or progress, and the Contractor shall provide proper facilities for such inspection access.

1-26 PRE-CONSTRUCTION CONFERENCE

The Contractor shall attend a preconstruction conference which will be held by the Engineer and Owner prior to the start of construction.

1-27 LAYOUT OF WORK AND SURVEYING

Refer to SS 3-10 Surveying.

The Drawings are based on aerial photography with contours of one-foot intervals. As such, the actual elevations of the ground surface may vary significantly (by several feet) from the actual elevations. The Contractor shall lay out the work to the lines, grades, and dimensions as shown on the Drawings.

Where construction operations require removal of property corners or pins, the Contractor shall provide for a registered civil engineer or licensed land surveyor to reference these points and replace them.

1-28 PROTECTION OF WORK AND MATERIALS

Refer to SS 4-2 and add the following:

When considered necessary and directed by the Engineer, materials and equipment shall be placed on wooden platforms or other hard, clean surfaces, and not on the ground; and/or they shall be placed under cover.

1-29 SUBSTITUTION OF MATERIALS AND EQUIPMENT

Refer to SS 4-5 and add the following:

The Drawings are detailed on the basis of specified materials and equipment. Due to the variation in available equipment, there are a few cases where it has been necessary to base the Drawings on one manufacturer's equipment only. In these cases, the second-named manufacturer and other approved equipment shall be considered as substituted equipment. Where any modifications or deviations from the Contract Drawings are required by the substitution of approved materials or equipment, the Contractor shall prepare and submit to the Engineer detailed drawings showing all modifications in structures, reinforcing steel, piping, electrical and mechanical work, etc., to adapt the Contract Drawings to the alternate materials or equipment; the Engineer will review such drawings and either approve them or indicate thereon changes necessary to comply with the project requirements. The Contractor shall revise any unapproved drawings and resubmit them to the Engineer.

The cost of the above drawings required as a result of substituted items of materials or equipment and the actual construction cost increase, if any, shall be included in the prices bid in the Proposal.

1-30 PLAN REVISIONS FOR CONTRACTOR'S PROPOSALS OF SUBSTITUTIONS

Proposals for substitutions of equipment or methods that deviate significantly from the Drawings and which will necessitate significant changes in the Engineer's Drawings or review of significantly different design concepts will only be considered if the Contractor is willing to provide for compensation to the Engineer to review the Proposal. Such compensation shall be by a pre-arranged deduction from the Contract Amount which will allow the Owner to compensate the Engineer as Extra Work under the Engineer/Owner Services Agreement.

The Engineer will determine when such Proposals will require significant changes and will promptly notify the Contractor of this determination.

Agreement for such a proposal review will require a proposal letter by the Contractor, accepted and acknowledged by the Engineer and Owner, which would be subsequently included in a Contract Change Order. Agreement to review a proposal will not in any way obligate the Engineer to recommend acceptance of the proposal to the Owner. Proposals will be recommended for approval only if the end product will be in the interest of the Owner after taking into account the costs for subsequent Drawing changes. The Engineer will need to be compensated for such subsequent Drawing changes and additional proposal reviews as necessary as an Extra Work item under the Engineer/Owner Services Agreements. Recommendation of acceptance of the proposal will be dependent on either the Contractor compensating the Owner for such costs in the proposal (by deductions from Contract Amounts) or by demonstrating in the proposal that the Owner will be receiving a superior product that justifies that the cost of Drawing changes be compensated for solely by the Owner. If a proposal is approved by the Owner, it will be incorporated into a Contract Change Order.

Either the time involved to review proposals or the subsequent denial of proposals shall not be considered as a reason for the Contractor to not complete the work within the specified time. However, proposals may involve extensions of time if in the interests of the Owner.

Proposals that result in an improvement to the project are encouraged, but only when the costs of review and administrative time and Drawing changes are included in the evaluation, and also when such proposals do not jeopardize the timely completion of the project.

1-31 LUMP-SUM PRICE BREAKDOWN

Refer to SS 7-2 and add the following:

Only items of work of value to the Owner (in the event of Contractor default) shall be included in the schedule. Items for mobilization, insurance, and other Contractor front-end costs are not allowed unless specifically included in the Proposal. The following items shall be included in the lump sum breakdown unless otherwise approved by the Engineer:

- | | |
|--|-----|
| 1. Bonds: | 1½% |
| 2. Cleanup: | 1% |
| 3. Testing: | 2% |
| 4. Shop Drawing Submittals: | 2% |
| 5. Equipment Information (Operation
and Maintenance Manuals): | ½% |

If shop drawing approval, cleanup, and testing proceed as the job progresses, then partial payments of these amounts will be made accordingly. Payment for bonds shall be paid on the first partial payment request, pursuant to the invoiced amount provided by the Contractor.

The Contractor shall provide a lump sum breakdown for all lump sum items as denoted in the Proposal that exceed \$10,000 in value. The Engineer may furnish the Contractor with a list of subjects and items to include in the lump sum price breakdown. The Contractor shall list after each item the approximate proportioned cost for that item. These costs shall include a pro-rata share of general overhead costs, bonds, insurance, mobilization and demobilization, etc. The Contractor may be asked to verify any items, which, in the Engineer's opinion, are out of balance.

1-32 COMPLIANCE WITH STATE SAFETY, OSHA, AND OTHER CODE REQUIREMENTS

The completed work shall include all necessary permanent safety devices such as machinery guards and similar ordinary safety items required by the State and Federal (OSHA) Industrial Safety Authorities and applicable local and national codes. Further, any features of the work subject to such safety regulations shall be fabricated, furnished, and installed in compliance with these requirements. The Contractor shall notify all manufacturers, equipment suppliers, and subcontractors of the provisions of this article.

In selecting and/or approving equipment for installation in the project, the Owner and Engineer assume no responsibility for injury or claims resulting from failure of the equipment to comply with applicable National, State, and local safety codes or requirements, or the safety requirements of a recognized agency, or failure due to faulty design concepts, or defective workmanship and materials.

1-33 WATER, SANITATION, POWER, AND TELEPHONE

Commercial power, sanitation, and telephone are not available at the construction site. The Contractor shall make the arrangements and pay all costs to provide temporary utilities for construction use. Water is available to the Contractor at no charge provided that it is used judiciously and provides all means of conveyance as required. The Owner will designate fire hydrants from which the Contractor can obtain water through an Owner-provided hydrant meter.

1-34 COORDINATION

Refer to SS 2-4.

Contractors shall cooperate in the coordination of their separate activities in a manner that will provide the least interference with others working in the area and in the interfacing of the separate elements of the overall project work.

All Contractors who have work on this project are subject to this requirement for cooperation and all shall abide by the Engineer's decision in resolving coordination and project sequence problems.

1-35 EQUIPMENT INFORMATION

The Engineer will provide a list of required equipment information, which will be check marked on the SHOP DRAWING AND EQUIPMENT INFORMATION CHECKLIST. This checklist will be supplied to the Contractor with the Notice to Proceed.

Written Equipment Manuals will be prepared by the Contractor from equipment information furnished by the manufacturers and suppliers of the installed equipment and materials. It is the

intent of this provision that reviewed and approved equipment manuals be supplied to the Owner prior to personnel training and facility startup.

The Contractor shall compile two (2) copies of the following information for each piece of electrical, mechanical, plumbing, and process equipment and materials installed in the project.

Original publications are preferred. Clean photocopies will be accepted at the discretion of the Engineer. Faxed or copies of faxed information will not be acceptable.

1. Descriptive literature (catalog cuts and data sheets with specific model numbers pointed out).
2. Parts lists.
3. Installation Manuals (if any exist).
4. Operation Manuals (if any exist).

The above information is required in addition to that furnished as shop drawings, even though for some equipment the final approved shop drawing submittals and the equipment information may be the same.

Each copy of this information shall be placed in a high quality, hard-backed binder with Table of Contents and numbered and labeled tabbed dividers separating the information for each of the major pieces of equipment. The Engineer may provide a Table of Contents sequence and the listing of the tabs to be used. If a sample Table of Contents is provided, the Contractor shall organize the above information in the provided sequence. All of the above information shall be provided to the Engineer before final payment is requested.

Upon receipt of the above information from the Contractor, the Engineer will check to see that the information is complete and correct, and the Contractor shall provide any additional information required by the Engineer to complete the Operation and Maintenance Manuals.

1-36 FORMAT OF TECHNICAL SPECIFICATIONS

Technical specifications are written in an abbreviated outline form and are included on the Drawings.

A reference to any Standard Specification (SS) or any other specification means that the Contractor shall perform the work in conformance with that specification. Statements of work such as excavate, install, provide, furnish, test, etc., without particular reference to who is doing the work shall be understood to be the Contractor. Simple reference of materials and/or equipment means the Contractor shall furnish these materials and/or equipment or an approved equivalent. In the absence of any statement regarding application or installation of materials or equipment, such item shall be installed or applied in accordance with the manufacturer's or supplier's instructions; or in the absence of such instructions, it shall be installed or applied pursuant to standard construction practice as approved by the Engineer.

1-37 SALVAGE OF MATERIALS AND EQUIPMENT

Unless otherwise indicated in the Drawings or Technical Specifications, all materials and equipment which are to be removed from the work, which in the Owner's opinion are valuable, shall remain the property of the Owner, and the Contractor shall carefully remove such materials and/or equipment and give them to the Owner.

1-38 OFF-SITE DISPOSAL OF MATERIALS

The Contractor shall make all arrangements for disposal of excess and waste material at off-site locations and shall pay all costs involved. Arrangements may include, but not be limited to, entering into agreements with property owners and obtaining necessary permits, licenses and environmental clearances. Before disposing of any material off the job site, the Contractor shall furnish to the Engineer satisfactory evidence that the Contractor has entered into agreements with the property owners of the site involved and has obtained said permits, licenses and clearances. The documentation provided shall verify that there will be no significant impact on wetlands, prime farmland, designated flood zones, or other sensitive environmental resources.

Contractor shall obtain necessary grading permits and submit copies to Engineer.

1-39 CONSTRUCTION OBSERVER

Refer to SS 3-4.

The Engineer will assign a Construction Observer as its representative to observe the work for conformance with the Drawings and Specifications. The Construction Observer will be responsible to notify the Contractor of any apparent violations of the Drawings and Specifications. If the Contractor disagrees with this interpretation, he shall notify the Engineer in writing immediately and request its written interpretation of the Drawings and Specifications.

1-40 SUSPENSION OF WORK

Delete SS 6-6.1 and substitute the following:

General. The work may be suspended in whole or in part when determined by the administrative officer of the Owner that the suspension is necessary in the interest of the Owner. The Contractor shall comply immediately with any written order of the Owner suspending work. Such suspension shall be without liability to the Contractor on the part of the Engineer or Owner except as otherwise specified in SS 6-4.3.

1-41 COMPETENT WORKERS

Refer to SS 5-3.1. The Engineer and/or the Owner has the authority to determine if workers are incompetent or otherwise unsuitable per this section, and the Contractor shall remove any such worker upon written request by either the Engineer and/or the Owner.

1-42 WORKING HOURS

The Contractor shall decide the working hours for the project, except that no work will be allowed on Saturdays, Sundays, or holidays officially recognized by the Owner, unless otherwise approved by the Owner and Engineer. Working hours for the Owner are between 8:00 a.m. and 5:00 p.m. The Contractor shall notify the Engineer in writing of its work schedule including hours to be worked and days off. The Contractor's representative shall be available at the work site during the hours indicated in the work schedule. The work schedule will be used by the Engineer to schedule construction observation personnel. No work shall be permitted outside the hours and days indicated by the schedule unless otherwise approved by the Engineer. If work on weekends or holidays is deemed necessary by the Contractor and agreed upon by the Owner and Engineer, the Contractor shall be back charged the cost difference between construction observation during normal working hours versus weekend hours. The back charge shall be processed in the form of a Contract Change Order.

1-43 LABOR CODE REQUIREMENTS

Refer to SS 5-3.

1. Payment of Less than Prevailing Rates

The Contractor and any subcontractor shall pay not less than the specified prevailing rates to all workmen employed in the execution of the Contract.

The Contractor shall, as a penalty to the Owner, forfeit moneys as indicated in the Labor Code for each calendar day, or portion thereof, for each worker paid less than the specified prevailing rates for the work or craft in which the worker is employed for any work done under by the Contractor or by any subcontractor. The amount of the forfeiture shall be determined by the State Labor Commissioner as provided by Section 1775 of the Labor Code. In addition, the difference between the specified prevailing rates and the amount paid each worker for each calendar day or portion thereof for which each worker was paid less than the specified prevailing rates shall be paid to each worker by the Contractor. A source of state wage rate information is the Department of Industrial Relations (DIR) which can be found at www.dir.ca.gov/DLSR/PWD.

2. Employment of Apprentices

The Contractor or a subcontractor who violates Section 1777.5 of the Labor Code governing employment of apprentices shall forfeit the sum of moneys as indicated in the Labor Code for each calendar day of noncompliance per Section 1777.7. Upon receipt of a determination that a penalty has been imposed, the Owner shall withhold the amount of the penalty from Contract progress payments then due or to become due.

3. Overtime Work

Eight hours labor constitutes a legal day's work, and the time of service of any workman shall be limited and restricted to 8 hours during any one calendar day and 40 hours during any one calendar week, except that work performed in excess of those hours shall be compensated for all hours worked in excess of 8 hours per day at not less than 1-½ times the basic rate of pay.

The Contractor shall, as a penalty to the Owner, forfeit moneys as indicated in the Labor Code for each workman employed in the execution of the work by the Contractor or by any subcontractor for each calendar day during which such workman is required or permitted to work more than 8 hours in any one calendar day and 40 hours in any one calendar week in violation of such provisions.

4. Payroll Records

Contractor shall keep accurate payroll records in format specified by the Division of Labor Standards Enforcement. Said information shall include, but not be limited to, a record of the name, address, social security number, work classification, straight time and overtime hours worked each day and week, and actual per diem wages paid to each journeyman, apprentice, or worker employed by the contractor. Copies of such record shall be made available for inspection at all reasonable hours, and a copy shall be made available to employee or its authorized representative, the Division of Labor Standards Enforcement, and the Division of Apprenticeship Standards in compliance with California Labor Code, Section 1776.

Contractor and Subcontractors shall furnish and submit electronic certified payrolls directly to the Labor Commissioner, and duplicate copies available to the Owner.

1-44 AUTHORITY OF ENGINEER

Refer to SS 3-4 and add the following paragraph at the end.

The Engineer will have authority to issue directives to the Contractor to make changes or additions to the work when in the Engineer's opinion it is obvious that delay in making the directive will undoubtedly cost the Owner additional extra work expense or that project completion will be significantly jeopardized. The Engineer will always attempt to secure the Owner's approval prior to the issuance of such directives. Such directives will only be made to achieve originally conceived project goals and not be used for extra nonessential items, except where the Engineer has a written approval of that item from the Owner. Where practical, the Engineer will always attempt to obtain a fair lump sum cost or basis of cost from the Contractor prior to proceeding with the work. In those cases where a directive must be given without an agreed cost, work shall be performed as EXTRA WORK in accordance with SS 7-4 and the Contractor shall provide the Engineer with the actual labor, materials and equipment costs as soon as they can be determined. A Contract Change Order to validate any directive shall be prepared by the Engineer at the earliest practical date.

1-45 MEASUREMENT AND PAYMENT

The prices bid in the Proposal shall be full compensation to the Contractor for furnishing all labor, equipment, supplies, materials (including taxes), tools, transportation, supervision, testing, overhead, profit, and any other related cost items necessary to perform all the work required in these Contract Documents. Items of work required herein but not specifically listed in the Proposal shall be deemed within the scope of work of the most applicable item in the Proposal. Specific limits of work may be established in the Drawings and technical specifications for some of the work items.

Within ten days after the Effective Date of the Contract (or as otherwise required by the Contract Documents), Contractor shall submit to Engineer for timely review a preliminary Schedule of Values for all of the Work including quantities and prices of items, which, when added together, equal the Contract Price and subdivides the Work into component parts in sufficient detail to serve as the basis for progress payments during performance of the Work. Such prices will include an appropriate amount of overhead and profit applicable to each item of Work.

Owner shall make progress payments on the basis of Contractor's Applications for Payment at an Owner/Contractor mutually agreed day of each month during performance of the Work as provided in SS 7-3, provided that such Applications for Payment have been submitted in a timely manner and otherwise meet the requirements of the Contract. All such payments will be measured by the Schedule of Values established as provided in the Special Provisions or, in the event there is no Schedule of Values, as provided elsewhere in the Contract.

1. Prior to Substantial Completion, progress payments will be made in an amount equal to the percentage indicated below but, in each case, less the aggregate of payments previously made and less such amounts as Owner may withhold, including but not limited to liquidated damages, in accordance with the Contract.
 - a. 95 percent of the value of the Work completed (with the balance being retainage).

- b. 95 percent of cost of materials and equipment not incorporated in the Work that has been approved and paid for as Materials On Hand (with the balance being retainage).

Unconditional waiver and releases upon progress payments in the form provided herein must be provided for the work covering the prior month's Application for Payment, unless otherwise agreed by Owner or Engineer. Upon Substantial Completion, Owner shall pay an amount sufficient to increase total payments to Contractor to 100 percent of the Work completed, less such amounts set off by Owner pursuant to SS 7-3, and less 200 percent of Engineer's estimate of the value of Work to be completed or corrected as shown on the punch list of items to be completed or corrected prior to final payment.

Upon final completion and acceptance of the Work, Owner shall pay the remainder of the Contract Price in accordance with SS 7-3 and the Special Provisions.

Progress payments will be made only for work items of value to the Owner in the event that the Contractor should default at any point during the project. Items for mobilization, insurance, and other Contractor's front-end costs are not allowed to be paid unless specifically listed in the Proposal. No payment can be made for construction materials not delivered to the project work site.

Progress payments will include an allowance of 100 percent of the value of acceptable materials and equipment, less the applicable retention, that are furnished and delivered to the project site and properly stored but not used. The Contractor shall furnish the Engineer with copies of invoices of the acceptable materials to assist in the determination of their value and that they are for this project, to establish the Owner's interest. The Contractor shall be responsible for damage or loss of all job-site materials, regardless of payment, until final project acceptance.

In addition to the applicable retention, the whole or part of any payment of the estimated amount due the Contractor may be withheld as an additional retention if, in the Engineer's opinion, such course be deemed necessary to protect the Owner from loss due to the Contractor's failure to perform any of the following: 1) meet its obligations; 2) expedite the work; 3) correct rejected work; 4) settle damages; or 5) meet the deadlines on the approved construction schedule, including approvable shop drawing submittal.

No estimate or payment shall be construed to be an acceptance of any defective work or improper materials.

Monthly progress payments (except for the final pay estimate) will not be made unless the value of the work results in an amount due of more than \$5,000.

The Contractor shall prepare the progress pay estimates using the attached "Contractor's Application for Payment", or similar.

At the request and expense of the Contractor, securities equivalent to the amount withheld may be substituted for such amount by deposit of such securities with the Owner, and the Owner will then pay the amount withheld to the Contractor. Upon satisfactory completion of the Contract, the securities will be returned to the Contractor. Alternately, the Contractor may request and the Owner shall make payment of retentions earned directly to the escrow agent at the expense of the Contractor as restricted by Section 22300 of the Public Contract Code.

Securities eligible for deposit by the Contractor shall include those listed in Section 16430 of the Government Code, bank or savings and loan certificates or deposit, interest bearing demand deposit accounts, standby letters of credit, or any other security mutually agreed to by the Contractor and the Owner.

The Contractor shall be the beneficial owner of any securities substituted for amounts withheld, and shall receive any interest thereon.

An escrow agreement shall be entered into between the Contractor and the Owner in the event the Contractor determines to substitute securities for amounts withheld. The form of the escrow agreement shall be substantially similar to that stated in Section 22300 of the Public Contract Code.

Payment shall be made within 30 calendar days following the submittal to the Owner of an undisputed progress payment request signed by both the Engineer and the Contractor, for the work completed, inspected, and approved by the Engineer.

Upon receipt of a payment request, the Owner shall act in accordance with both of the following:

Each payment request shall be reviewed by the Engineer within ten (10) days after receipt for the purpose of determining that the payment request is a proper payment request.

Any payment request determined not to be a proper payment request suitable for payment shall be returned to the Contractor as soon as practicable, but not later than ten (10) days, after receipt. A request returned pursuant to this paragraph shall be accompanied by a document setting forth in writing the reasons why the payment request is not proper.

Engineer shall submit recommendation of payment request to Owner. Owner shall pay Contractor all undisputed and properly submitted amounts within thirty (30) days after receipt by Owner of an undisputed and properly submitted payment request.

For purposes of this section:

A "progress payment" includes all payments due the Contractor, except that portion of the final payment designated by the Contract as retention earnings.

A payment request shall be considered properly executed if funds are available for payment of the payment request, and payment is not delayed due to an audit inquiry by the financial officer of the Owner.

Prior to substantial completion, the Owner, with the approval of the Engineer and with the concurrence of the Contractor, may use any completed or substantially completed portions of the work. Such use shall not constitute an acceptance of such portions of the work.

Final payment of retention shall be paid within the 60-day time limit after the date of completion of the work of improvement and in full accordance with and subject to any withholding under Public Contracting Code 7107.

In accordance with State of California Public Contract Code 7100, final payment of undisputed contract amounts is contingent upon the Contractor furnishing a release to the Owner and the Engineer as agent of the Owner from all claims and all liability to the Contractor for all things

done or furnished in connection with the undisputed work and every act of the Owner and others relating to or arising out of the work. A form is attached which is to be submitted for this purpose. Disputed contract claims in stated amounts may be specifically excluded by the Contractor from the operation of the release. No payment, however, final or otherwise, shall operate to release the Contractor or its sureties from obligations under this Contract and the Performance Bond, Payment Bond, and other bonds and warranties as herein provided.

1-46 FIRE PREVENTION

The Contractor shall, at all times, exercise extreme care in public and private lands to prevent forest, grass, building (structures) and brush fires. The Contractor, prior to bidding, shall determine all regulations and rules relating to fire prevention and shall abide by them.

1-47 AUTHORITY TO PROVIDE A SERVICE

The Contractor must have legal authority to complete the service they are providing in the state of their residence.

1-48 PRECEDENCE OF CONTRACT DOCUMENTS

Refer to SS 3-7.2. Modify the precedence listing as follows:

The precedence shall be:

- 1) Permits from other agencies as may be required by law.
- 2) Change orders and supplemental agreements, whichever occurs last.
- 3) Contract/Agreement.
- 4) Addenda.
- 5) Bid/Proposal.
- 6) Special Provisions.
- 7) Technical Specifications.
- 8) Drawings.
- 9) Standard Specifications.
- 10) Reference Specifications.

RELEASE OF CLAIMS

PROJECT: WASHBURN BUE DOG PARK PROJECT

OWNER: BURNEY WATER DISTRICT

ENGINEER: PACE ENGINEERING, INC.

CONTRACTOR: _____

The acceptance by the Contractor of the final payment for work shall release the Owner and the Engineer as agent of the Owner from all claims and all liability to the Contractor for all things done or furnished in connection with the work and every act of the Owner and others relating to or arising out of the work, except for previously disputed work. Disputed work will only be considered for possible future payment if it has been properly brought to the Engineer's attention and processed pursuant to General Provisions SS 2-9 CHANGED CONDITIONS and SS 2-10 DISPUTED WORK. The Contractor agrees there are no other claims that will be made, except those properly processed pursuant to these General Provisions. Previously disputed contract claims in stated amounts (if properly processed as disputed work) are specifically excluded by the Contractor from the operation of this release. No payment, however, final or otherwise, shall operate to release the Contractor or its sureties from obligations under this Contract and the Performance Bond, Labor and Materials Bond, and other bonds and warranties as herein provided.

Printed Name of Contractor's Representative
with Authority to Act for Contractor

Signature

Date

BURNEY WATER DISTRICT WASHBURN BUE DOG PARK

FUNDING FOR THIS PROJECT HAS BEEN PROVIDED IN FULL BY STATE OF CALIFORNIA
NATURAL RESOURCES AGENCY DEPARTMENT OF PARKS AND RECREATION PER CAPITA
GRANT PROGRAM PROJECT NO. 18-45-006

LINE LEGEND

---	(E) PAVEMENT
---	(N) PAVEMENT
---	(E) CONC
---	(N) CONC
—w—	(N) WATER LINE
—(E)W—	(E) WATER LINE
—O/H—	(E) OVERHEAD LINE
—x—	(E) FENCE
—□—□—□—	(N) 6' HIGH CHAIN LINK FENCE (295 LF)
—○—○—○—	(N) 5' HIGH CHAIN LINK FENCE (460 LF)
////	DEMO LINE

HATCH LEGEND

[Pattern]	(E) CONCRETE
[Pattern]	(E) PAVEMENT
[Pattern]	(N) 2" HMA OVER 6" AB
[Pattern]	(N) 6" DG

ABBREVIATIONS

AB	AGGREGATE BASE
BWD	BURNEY WATER DISTRICT
∅	DIAMETER
CF	CUBIC FOOT
COMP	COMPRESSION
DG	DECOMPOSED GRANITE
(E)	EXISTING
ELB	ELBOW
EG	EXISTING GRADE
FP	FINISH PAVEMENT
GALV	GALVANIZED
GSP	GALVANIZED STEEL PIPE
HB	HOSE BIB
HMA	HOT MIX ASPHALT
IRR	IRRIGATION
LF	LINEAL FEET
MIN	MINIMUM
MAX	MAXIMUM
(N)	NEW
O.C.	ON CENTER
PE	POLYETHYLENE
PVC	POLYVINYL CHLORIDE
R	RESTRAINED
STD	STANDARD
TBR	TO BE REMOVED
TC	TOP CONC/CURB
VIF	VERIFY IN FIELD
TYP	TYPICAL
W	WATER
W/	WITH
WL	WATER LINE
WS	WATER SERVICE

SYMBOL LEGEND

○	(N) BOLLARD/POST
→	DRAINAGE DIRECTION ARROW
[E]	ELECTRICAL PANEL / BOX
⊕	(E) FIRE HYDRANT
⊕	(N) HOSE BIB
⊕	(E) LIGHT POLE
⊕	(E) JOINT UTILITY POLE
⊕	(E) SANITARY SEWER MANHOLE
⊕	(E) UTILITY VAULT (MISCELLANEOUS)
⊕	(E) WATER METER/BOX
⊕	(E) WATER VALVE
⊕	(N) WATER VALVE
↕	SLOPE DIRECTION MARKERS

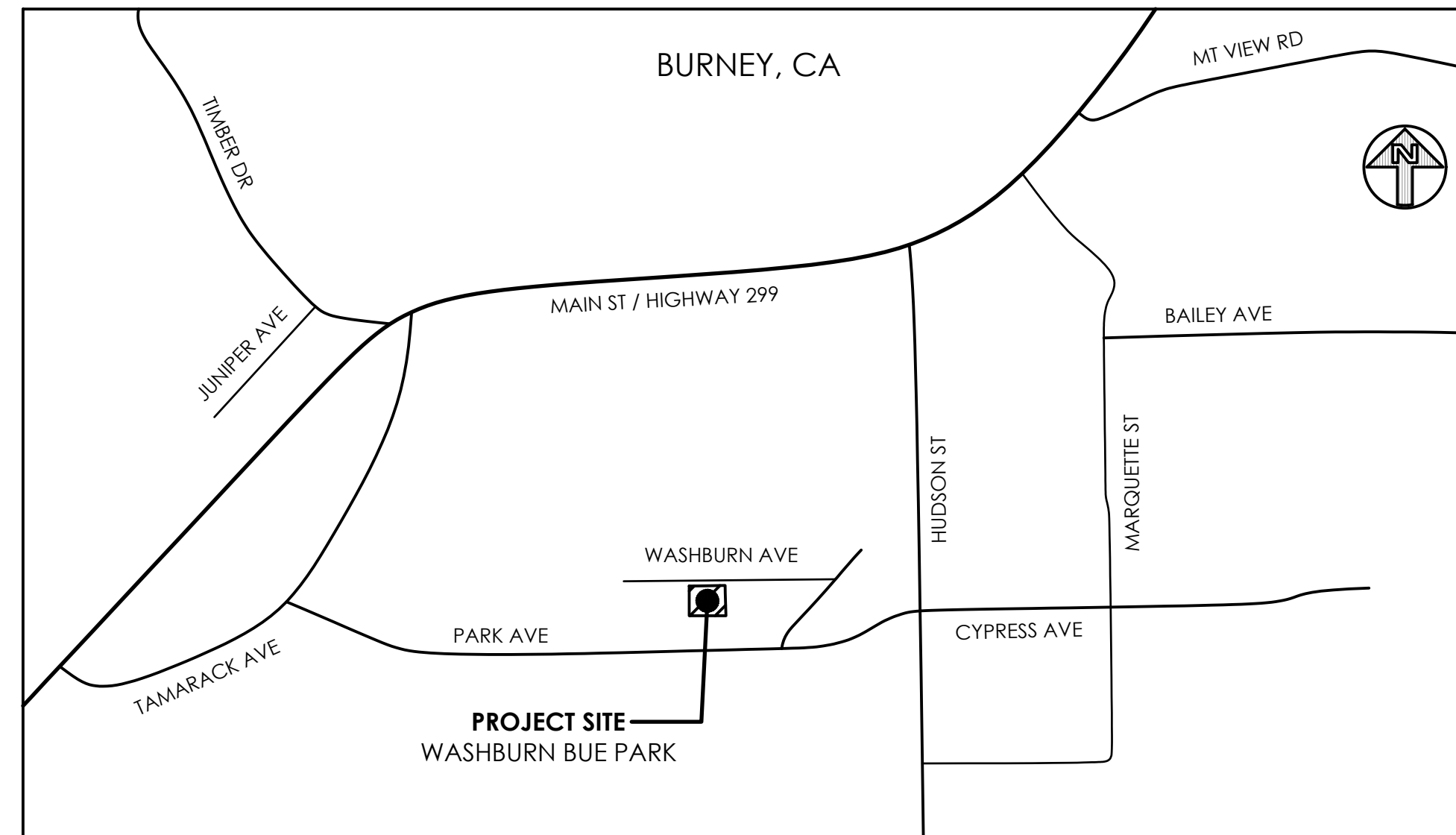

PROJECT LOCATION MAP
NTS

BOARD OF DIRECTORS

BRITTA RODGERS	PRESIDENT
SARAH CLARK	DIRECTOR
JIM HAMLIN	DIRECTOR
FRED RYNESS	DIRECTOR
DAVID BARRY	DIRECTOR

PACE DESIGN TEAM

TROY JONES	PROJECT MANAGER
JESSICA CHANDLER	PROJECT ENGINEER
RYAN TURNER	STAFF ENGINEER

DISTRICT STAFF

DAVID ZEVELY	DISTRICT MANAGER
MIKE SKELLY	FIELD SUPERINTENDENT
STEPHANIE McQUADE	ADMINISTRATIVE ASSISTANT

NOTES

- THE CONSTRUCTION AND INSTALLATION OF IMPROVEMENTS SHALL CONFORM TO THESE PLANS AND THE STANDARD SPECIFICATIONS FOR PUBLIC WORKS CONSTRUCTION (GREEN BOOK).
- CALL USA (1-800-227-2600) TO LOCATE ALL UTILITIES 48 HOURS PRIOR TO ANY CONSTRUCTION.
- USE TRENCH BACKFILL DETAIL 6 ON SHEET C4.1 FOR (N) 1" WATER LINE.
- ALL GRADES SHOWN ARE FINISH GRADES. ALLOW FOR VARIOUS THICKNESS OF BASE, PAVING AND CONCRETE IN PREPARING SUBGRADE.
- GRADE SITE TO THE GRADES SHOWN. COMPACT FILL AREAS AND TOP 6" OF CUT AREAS TO 95% OF MAXIMUM DENSITY AS MEASURED BY ASTM D-1557. IMPORT OR EXPORT AS NECESSARY.
- ALL AREAS TO RECEIVE FILL ARE TO BE SCARIFIED A MINIMUM DEPTH OF 8", MOISTURE CONDITIONED, AND COMPACTED TO 95% OF MAXIMUM DENSITY AS MEASURED BY ASTM D-1557.
- ANY CHANGES IN THESE PLANS ARE TO RECEIVE PRIOR APPROVAL OF BURNEY WATER DISTRICT AND PACE ENGINEERING, INC.
- HOT MIX ASPHALT (HMA) SHALL CONFORM TO THE REQUIREMENTS OF THE STATE OF CALIFORNIA DEPARTMENT OF TRANSPORTATION (CALTRANS) STANDARD SPECIFICATIONS FOR BE TYPE A, 1/2-INCH MAXIMUM SIZE AGGREGATE. ASPHALT BINDER SHALL BE PG 64-28.
- AGGREGATE BASE SHALL BE 3/4" CLASS 2 AGGREGATE BASE PER STATE SPECIFICATIONS, SECTION 26. COMPACT TO 95% OF MAXIMUM DENSITY AS MEASURED BY ASTM D-1557.
- DECOMPOSED GRANATE SHALL BE PER STATE SPECIFICATIONS, SECTION 20-5.03D(2)(g). COMPACT TO 95% OF MAXIMUM DENSITY AS MEASURED BY ASTM D-1557.
- POTHOLE AND VERIFY LOCATIONS OF ALL PIPE AND UTILITY CROSSINGS, IF ANY, PRIOR TO CONSTRUCTION.
- ALL (N) PARK EQUIPMENT AND ACCESSORIES SHALL BE INSTALLED PER MANUFACTURES RECOMMENDATIONS.
- PARK BENCHES TO PLACED IN A LOCATION AS DIRECTED BY DISTRICT.

SHEET INDEX		
PAGE	SHEET	TITLE
1	T1.0	TITLE SHEET
2	C1.0	DEMOLITION PLAN
3	C2.0	SITE PLAN
4	C3.0	GRADING AND UTILITY PLAN
5	C4.0	DETAILS
6	C4.1	DETAILS



GENERAL INFORMATION

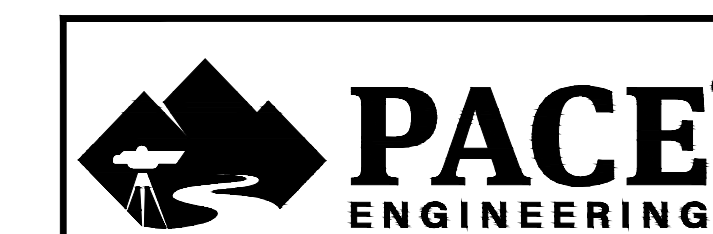
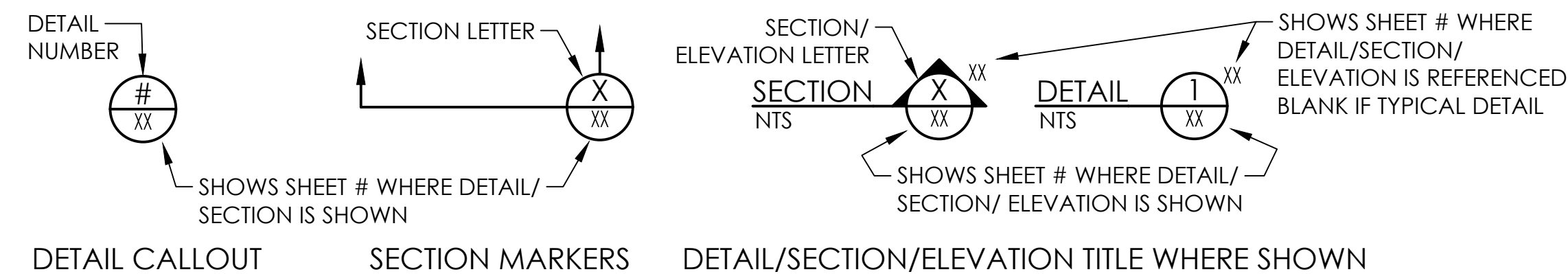

03/31/23

0306.45

SHEET
T1.0
PG 1 OF 6

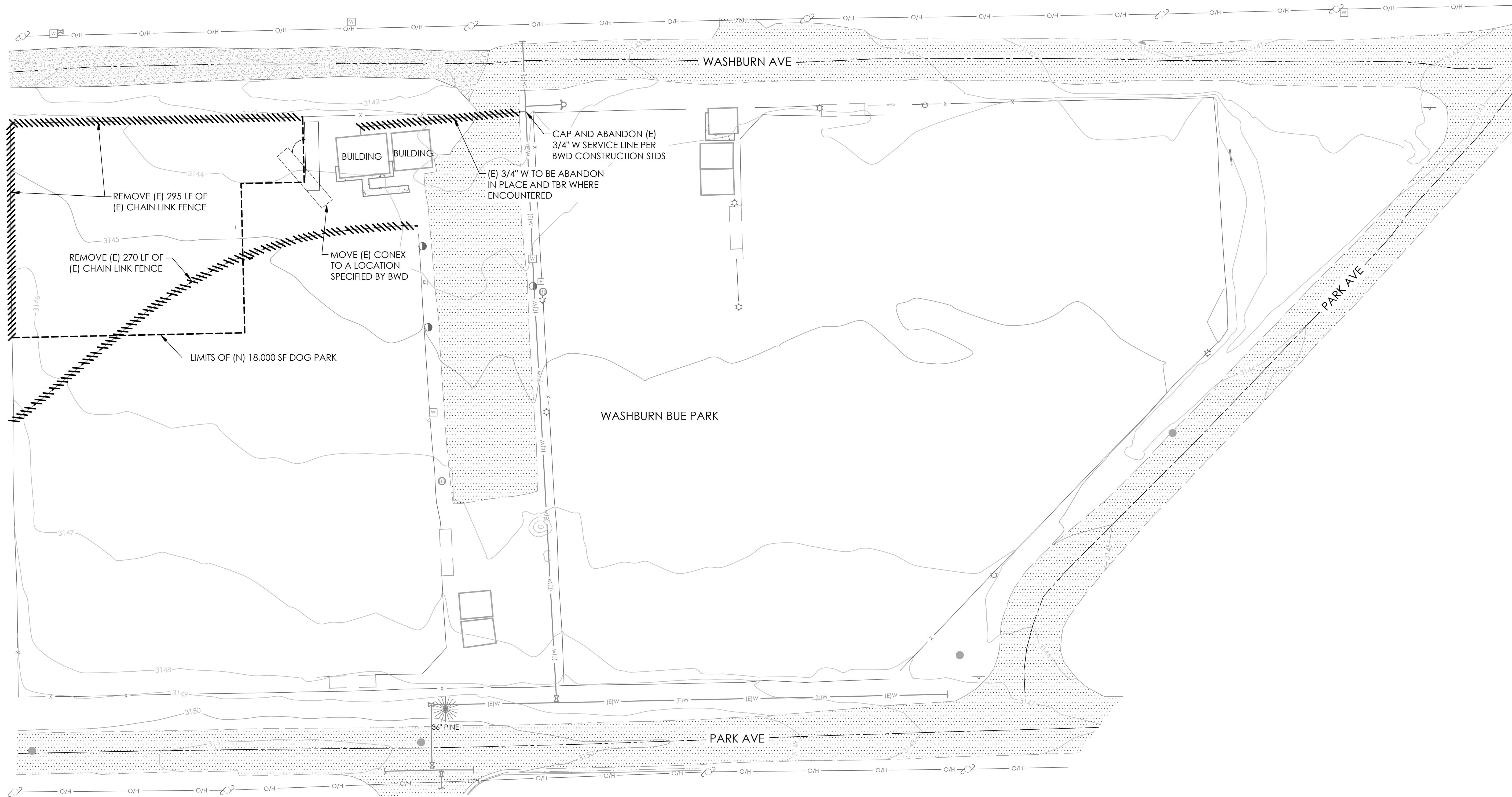

NOTES
 1. SEE SHEET T1.0 FOR LEGEND AND ABBREVIATIONS



DEMOLITION PLAN
 1" = 30'

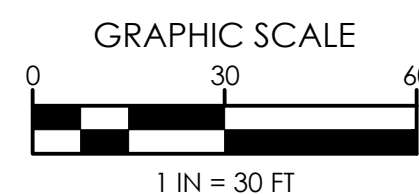

BAR IS ONE INCH ON ORIGINAL DRAWING
 0' ————— 1"
 IF NOT ONE INCH ON THIS SHEET, ADJUST SCALES ACCORDINGLY.

REVISIONS		
NO	DATE	DESCRIPTION

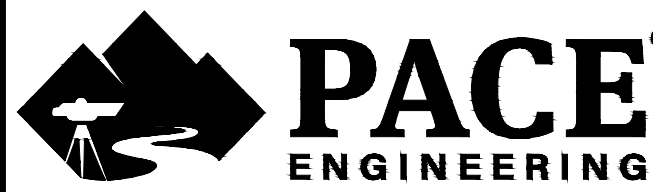

DES: TJ/RT CKD: TJ JOB NO.
 DRN: RT DATE: 03/31/23 0306.45

SIGNED _____

BURNEY WATER DISTRICT
 WASHBURN BUE DOG PARK
 DEMOLITION PLAN

SHEET
C1.0
 PG 2 OF 6

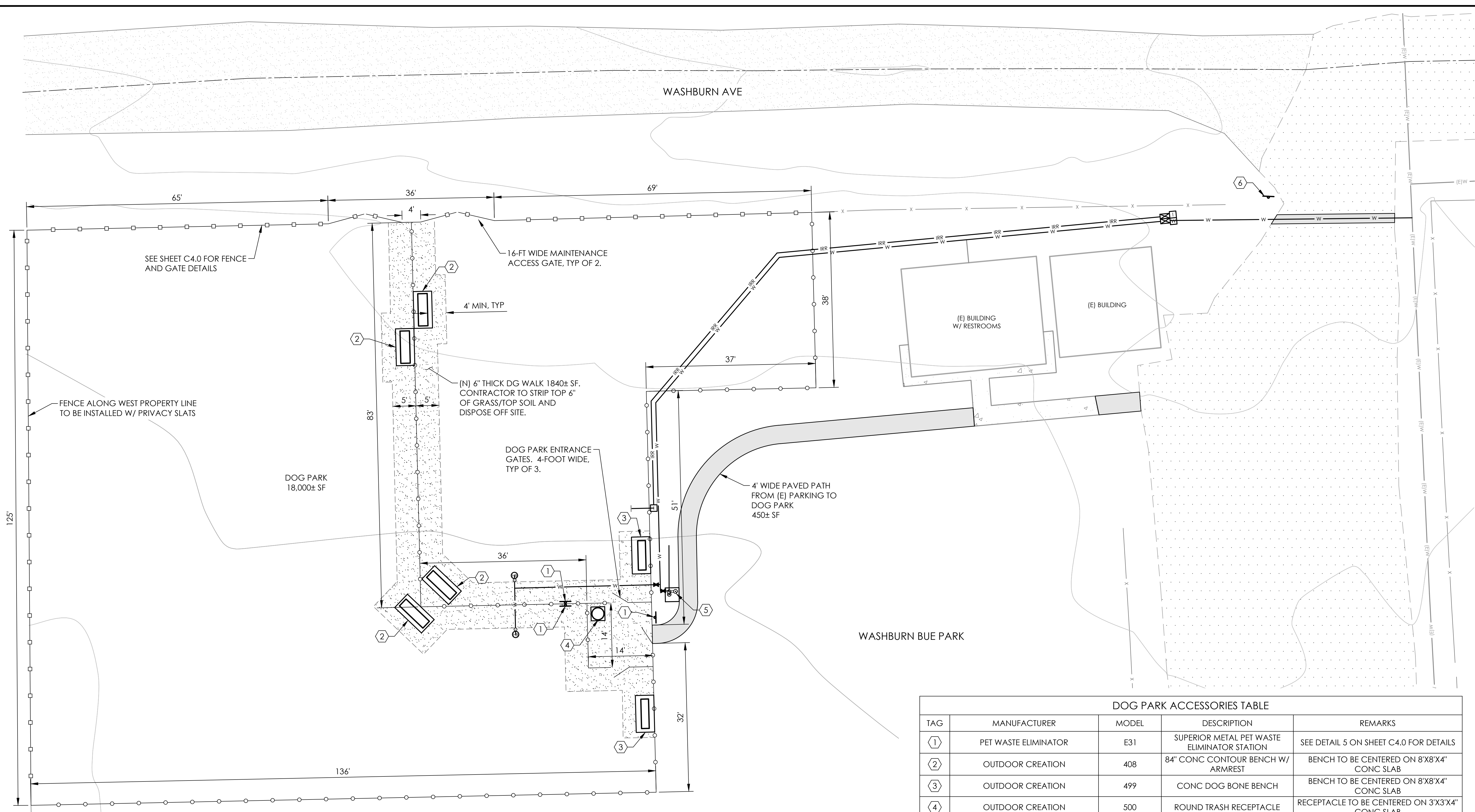

- NOTES
- SEE SHEET T1.0 FOR LEGEND AND ABBREVIATIONS
 - FINAL BENCH LOCATIONS TO BE DETERMINED BY THE OWNER



DOG PARK ACCESSORIES TABLE				
TAG	MANUFACTURER	MODEL	DESCRIPTION	REMARKS
①	PET WASTE ELIMINATOR	E31	SUPERIOR METAL PET WASTE ELIMINATOR STATION	SEE DETAIL 5 ON SHEET C4.0 FOR DETAILS
②	OUTDOOR CREATION	408	84" CONC CONTOUR BENCH W/ ARMREST	BENCH TO BE CENTERED ON 8'X8'X4" CONC SLAB
③	OUTDOOR CREATION	499	CONC DOG BONE BENCH	BENCH TO BE CENTERED ON 8'X8'X4" CONC SLAB
④	OUTDOOR CREATION	500	ROUND TRASH RECEPTACLE	RECEPTACLE TO BE CENTERED ON 3'X3'X4" CONC SLAB
⑤	MOST DEPENDABLE FOUNTAINS .INC	440 SM	OUTDOOR DRINKING FOUNTAIN W/ ATTACHED PET FOUNDATION	BI-LEVEL PEDESTAL WITH PET FOUNDATION CENTERED ON 3'X3'X4" CONC SLAB
⑥	CAMPGROUND SIGNS	K-6961 & K-5274	PARK RULES SIGNS	SEE DETAIL 3 ON SHEET C4.0 FOR DETAILS

REVISIONS		
NO	DATE	DESCRIPTION

PACE ENGINEERING

DES: TJ/RT CKD: TJ JOB NO. 0306.45
 DRN: RT DATE: 03/31/23

SIGNED

BURNEY WATER DISTRICT
 WASHBURN BUE DOG PARK

SITE PLAN

SHEET

C2.0

PG 3 OF 6

Plot Date: March 31, 2023 - 2:20 pm Login Name: tjones
 File Name: M:\land projects\0306.45 washburn bue dog park\0401 Site Plan.dwg Layout: SITE PLAN

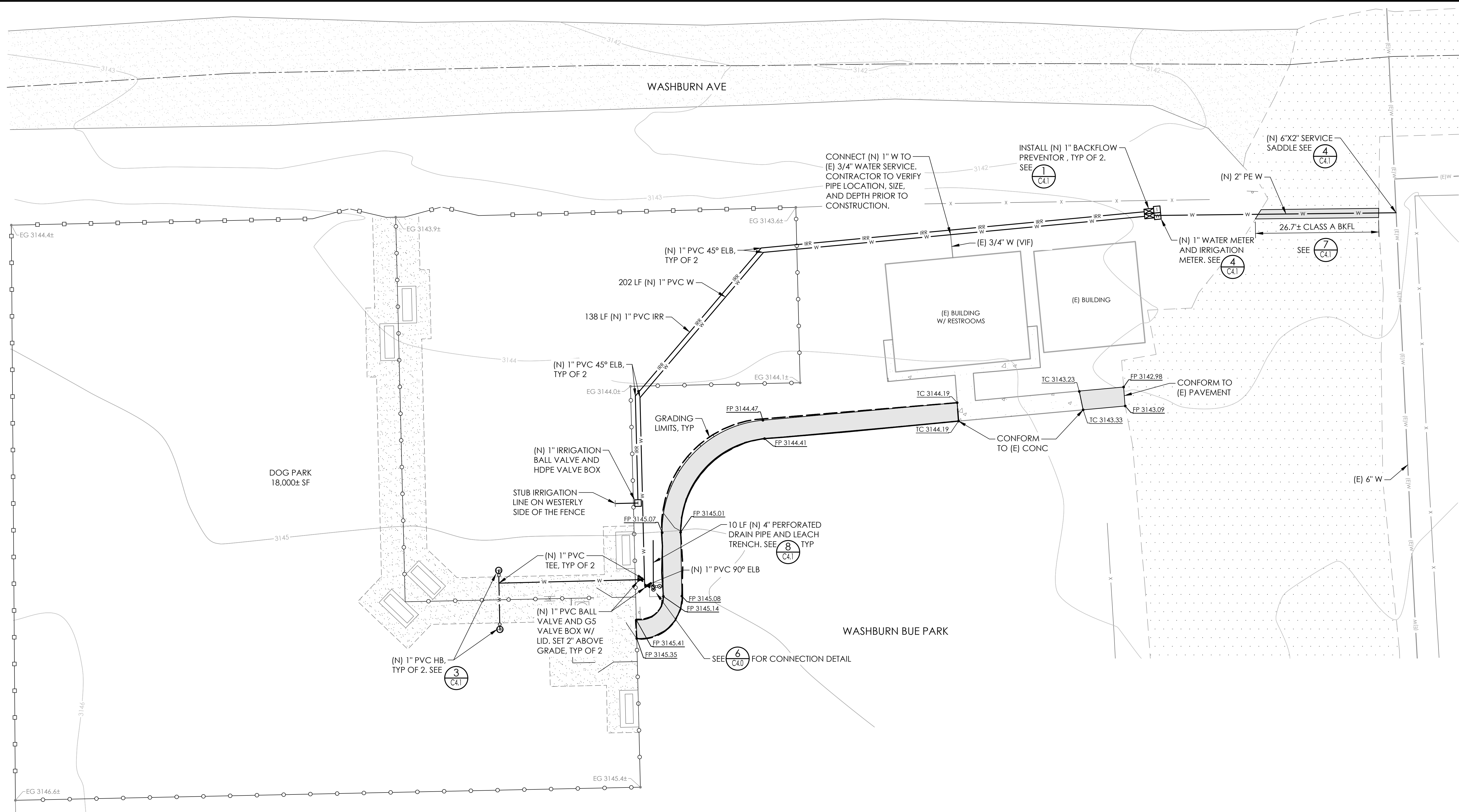

NOTES
 1. SEE SHEET T1.0 FOR LEGEND AND ABBREVIATIONS



BAR IS ONE INCH ON ORIGINAL DRAWING
 0' 1"
 IF NOT ONE INCH ON THIS SHEET, ADJUST SCALES ACCORDINGLY.

REVISIONS		
NO	DATE	DESCRIPTION

DES: TJ/RT CKD: TJ JOB NO. 0306.45
 DRN: RT DATE: 03/31/23

SIGNED

BURNEY WATER DISTRICT
 WASHBURN BUE DOG PARK
 GRADING AND UTILITY PLAN

SHEET
C3.0
 PG 4 OF 6

TYPICAL MEMBER DIMENSIONS		
	H = 5'-0"	H = 6'-0"
D	2'-6"	2'-6"
B	8"	10"
X	1-1/2" (MIN)	2" (MIN)

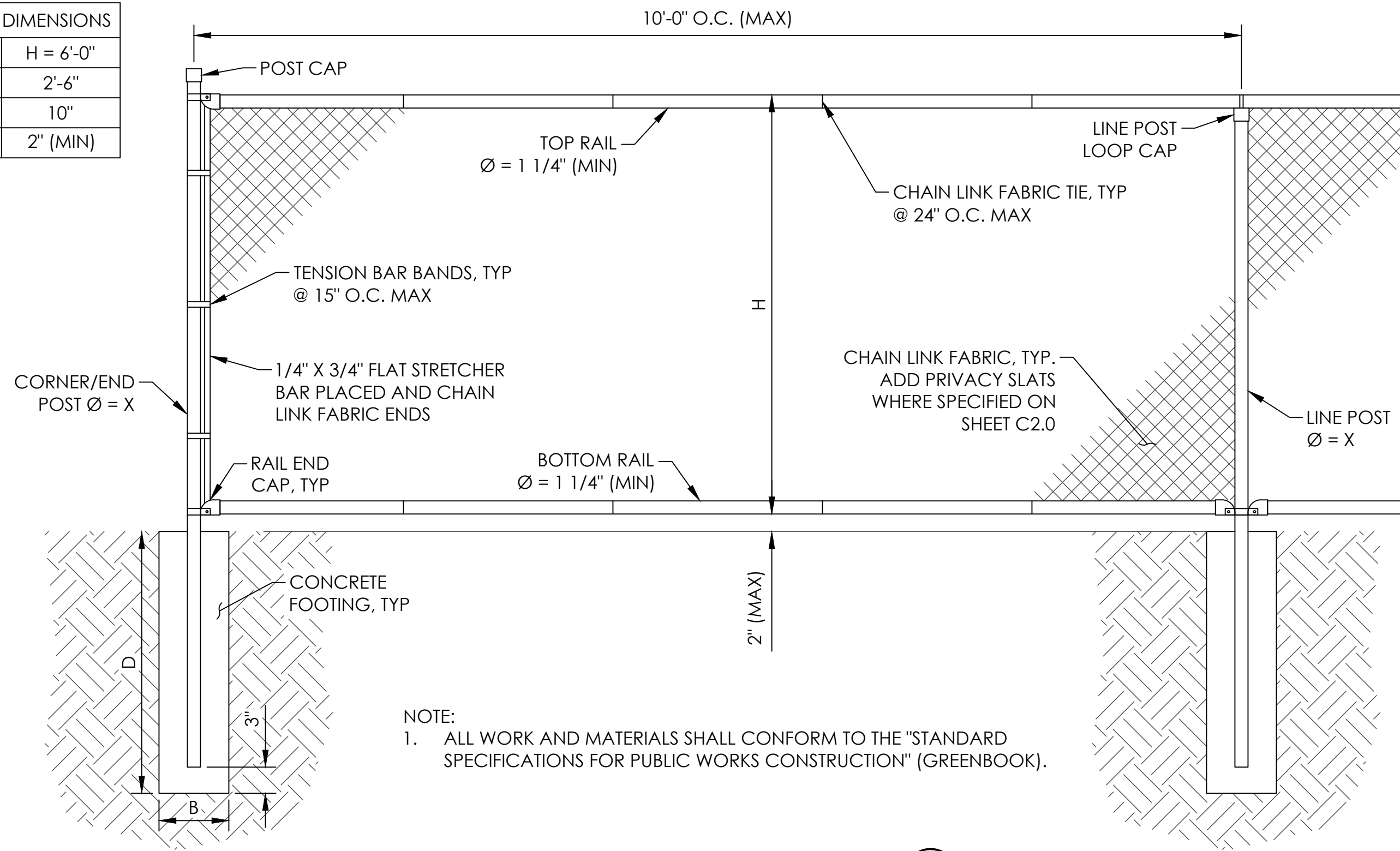

TYPICAL CHAIN LINK FENCE DETAIL
NTS (1) C4.0

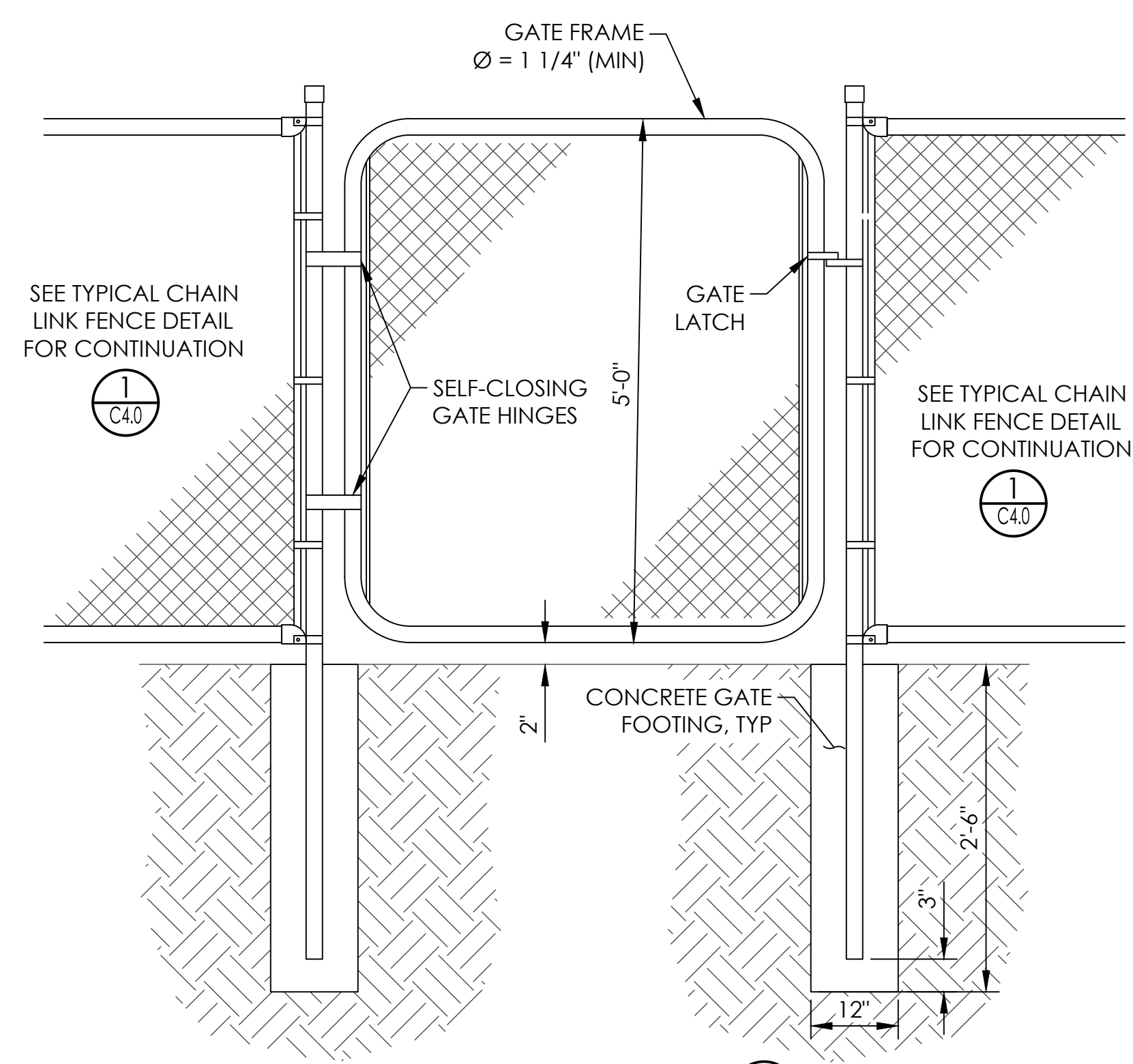

ENTRANCE GATE DETAIL
NTS (2) C4.0

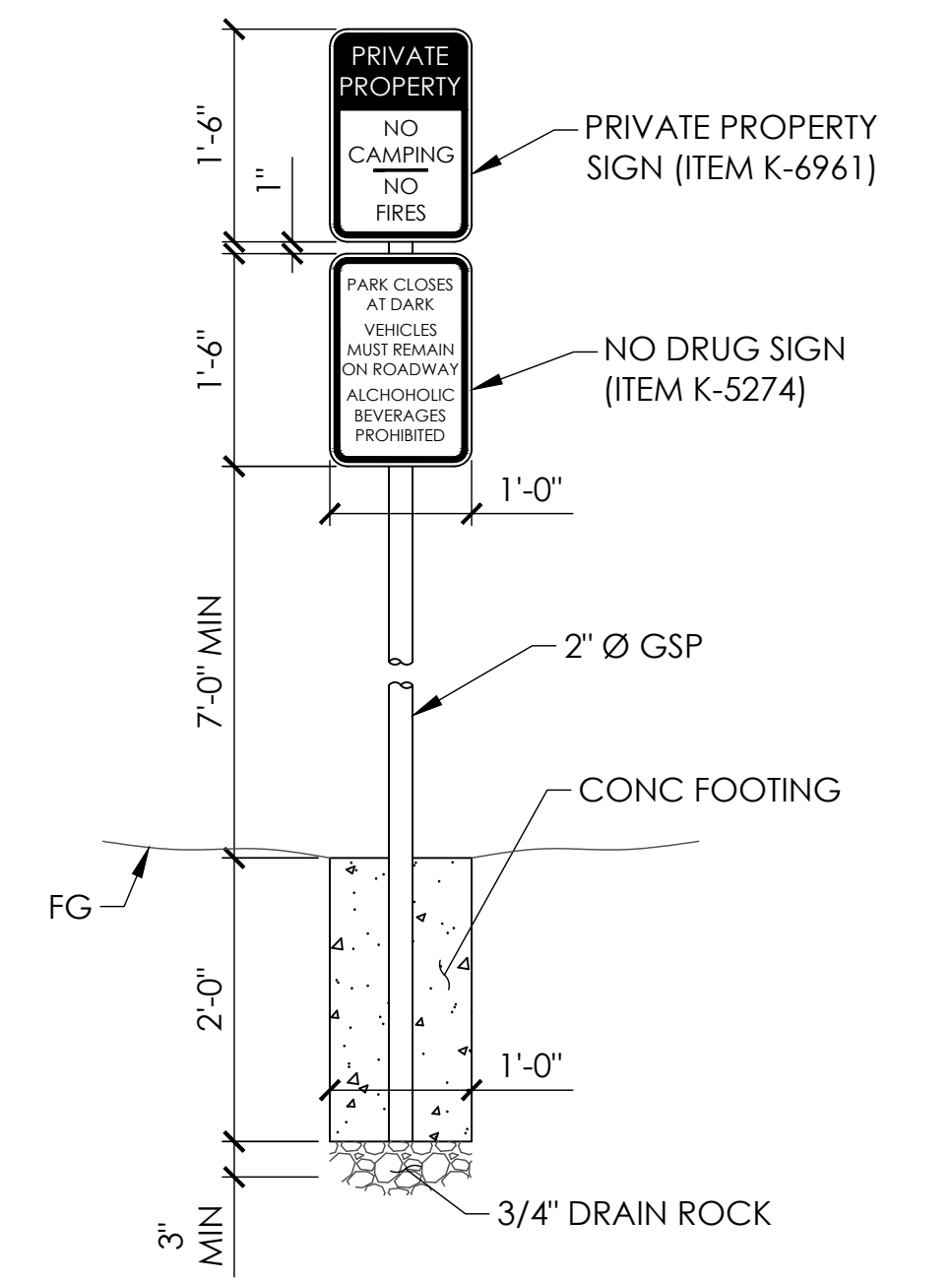

NOTES:
1. ITEMS SHOWN ARE PER CAMPGROUNDSIGNS.COM, OR APPROVED EQUAL.
2. INSTALLATION TO BE COMPLETED IN ACCORDANCE WITH MANUFACTURER'S SPECIFICATIONS.

PARK RULES SIGNAGE DETAIL
NTS (3) C4.0

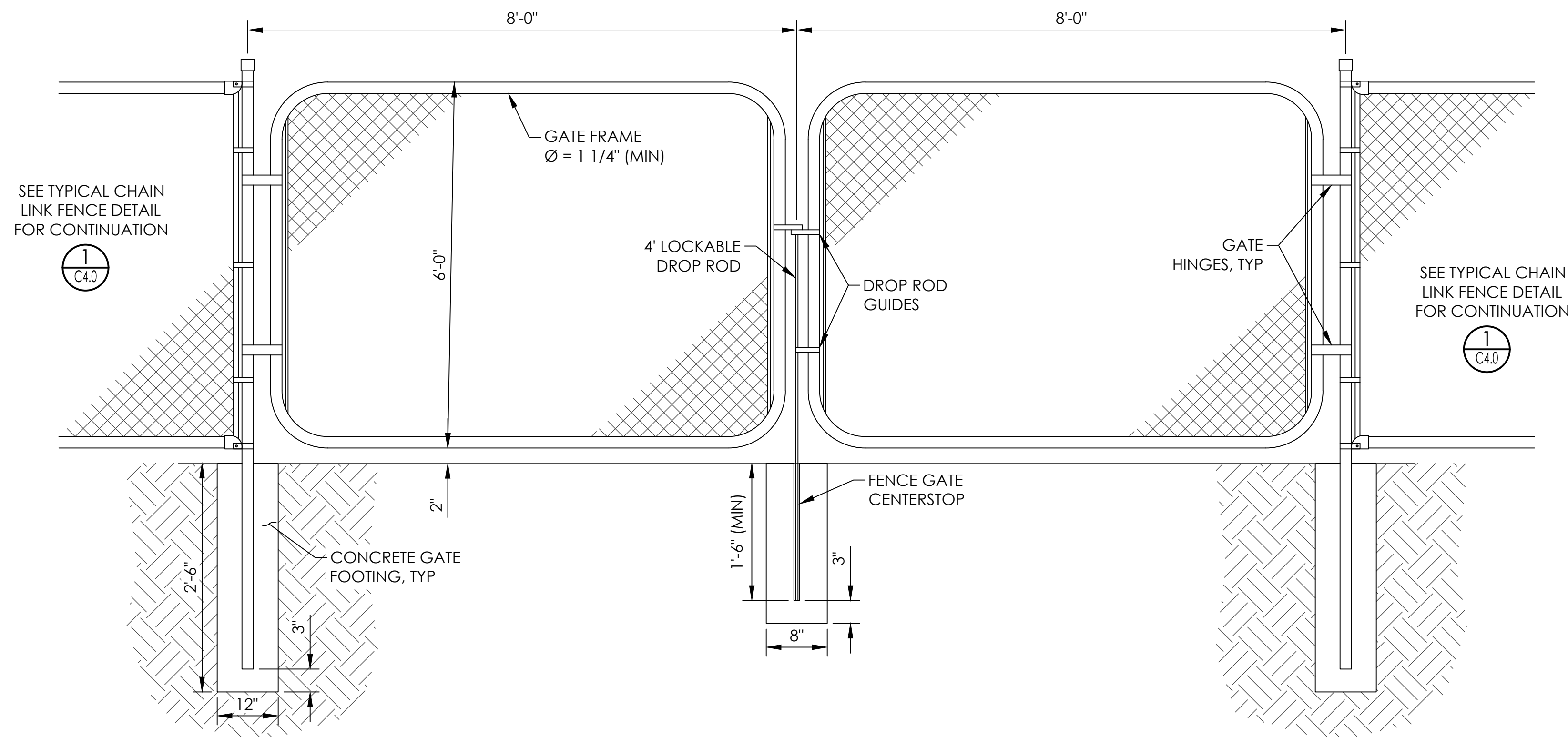

DRIVABLE GATE DETAIL
NTS (4) C4.0

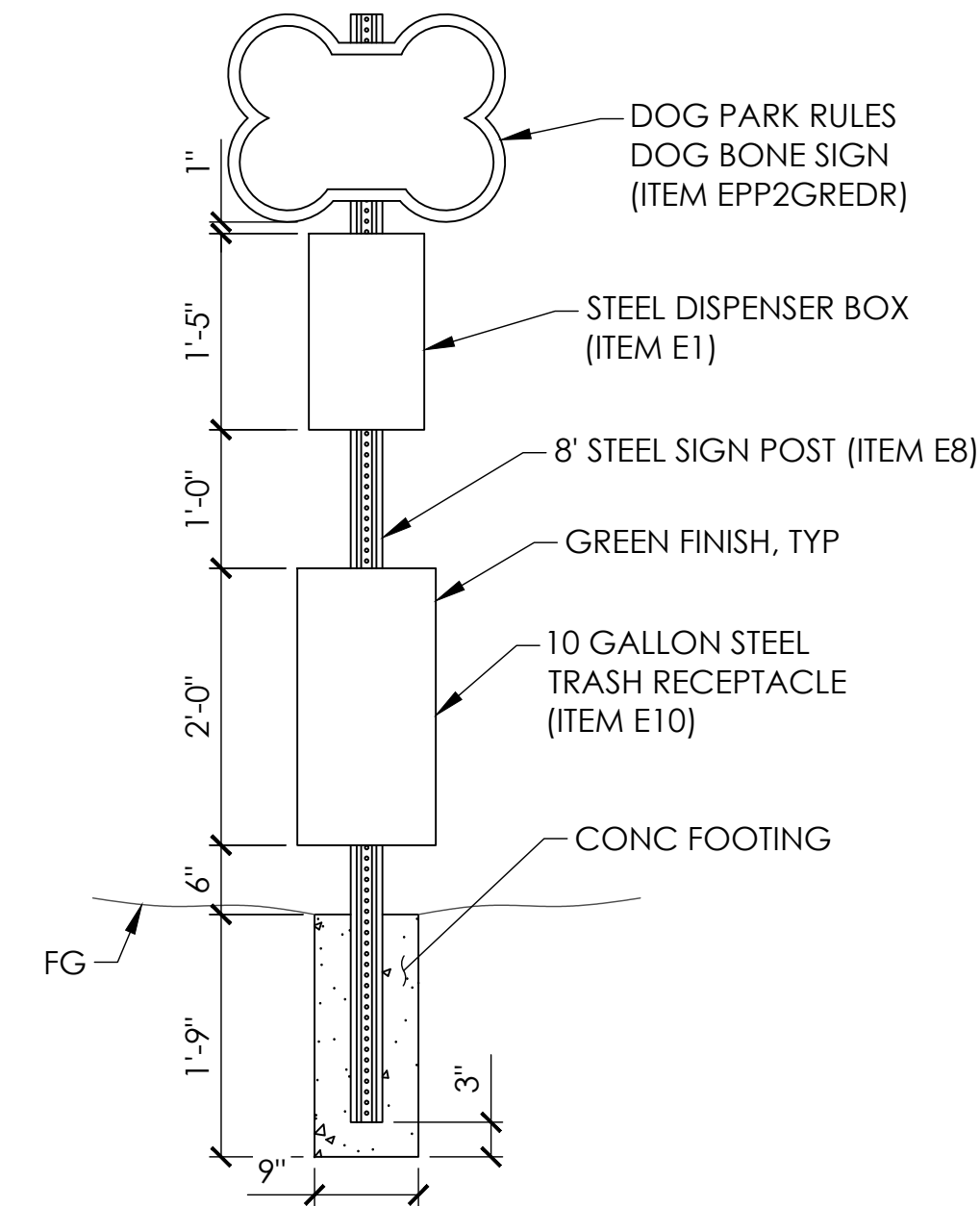

NOTES:
1. ITEMS SHOWN ARE PER PET WASTE ELIMINATOR COMMERCIAL PET WASTE DISPOSAL SYSTEMS, OR APPROVED EQUAL.
2. INSTALLATION TO BE COMPLETED IN ACCORDANCE WITH MANUFACTURER'S SPECIFICATIONS.

PET WASTE STATION DETAIL
NTS (5) C4.0

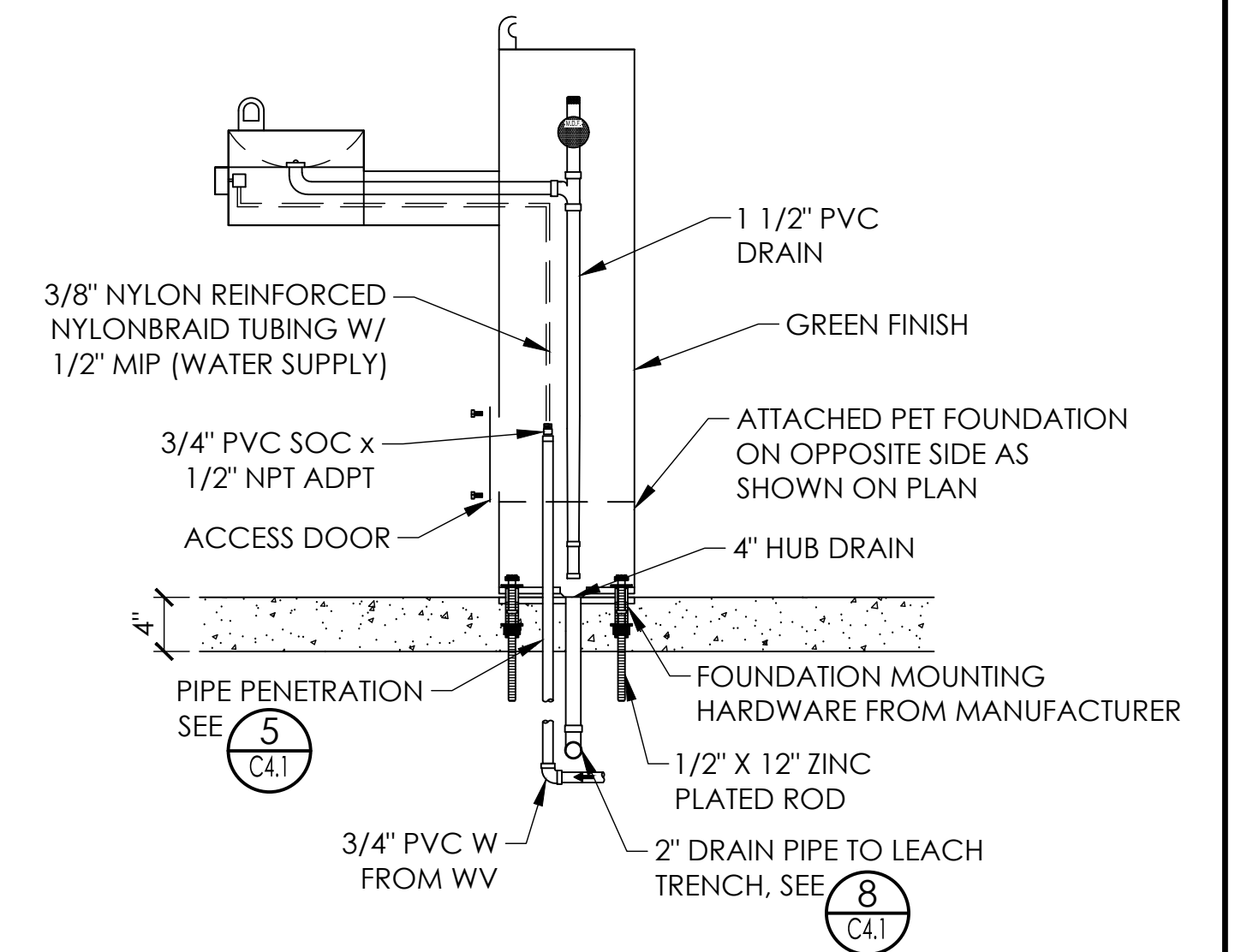

NOTES:
1. DRINKING FOUNTAIN TO BE MODEL 440 SM W/ ATTACHED PET FOUNDATION PER MOST DEPENDABLE FOUNTAINS INC, OR APPROVED EQUAL.
2. INSTALLATION TO BE COMPLETED IN ACCORDANCE WITH MANUFACTURER'S SPECIFICATIONS.

MDF MODEL 440 SM CONNECTION DETAIL
NTS (6) C4.0

BAR IS ONE INCH ON ORIGINAL DRAWING

0" 1"

IF NOT ONE INCH ON THIS SHEET, ADJUST SCALES ACCORDINGLY.

REVISIONS		
NO	DATE	DESCRIPTION

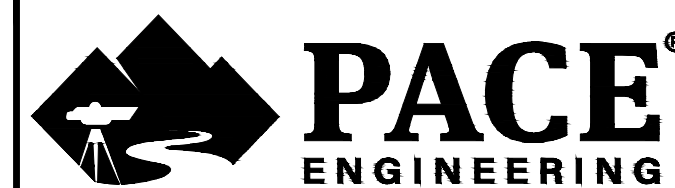

DES: TJ/RT CKD: TJ/JC JOB NO. 0306.45
DRN: RT DATE: 03/31/23

SIGNED

BURNEY WATER DISTRICT
WASHBURN BUE DOG PARK

DETAILS

SHEET

C4.0

PG 5 OF 6

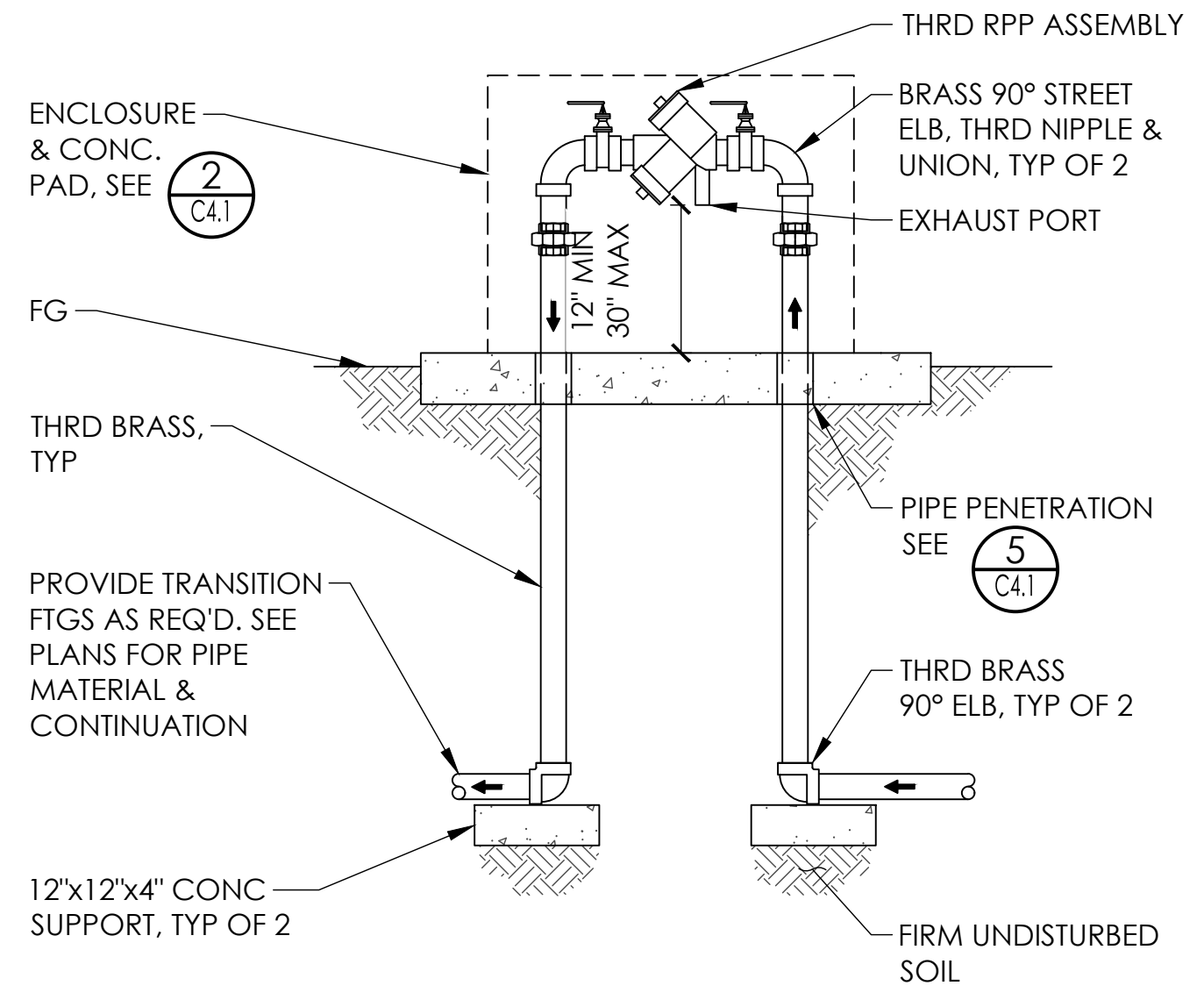

NOTES:
1. CONTRACTOR SHALL PROVIDE INSULATING BLANKET

BACKFLOW PREVENTOR DETAIL (1) NTS C4.1

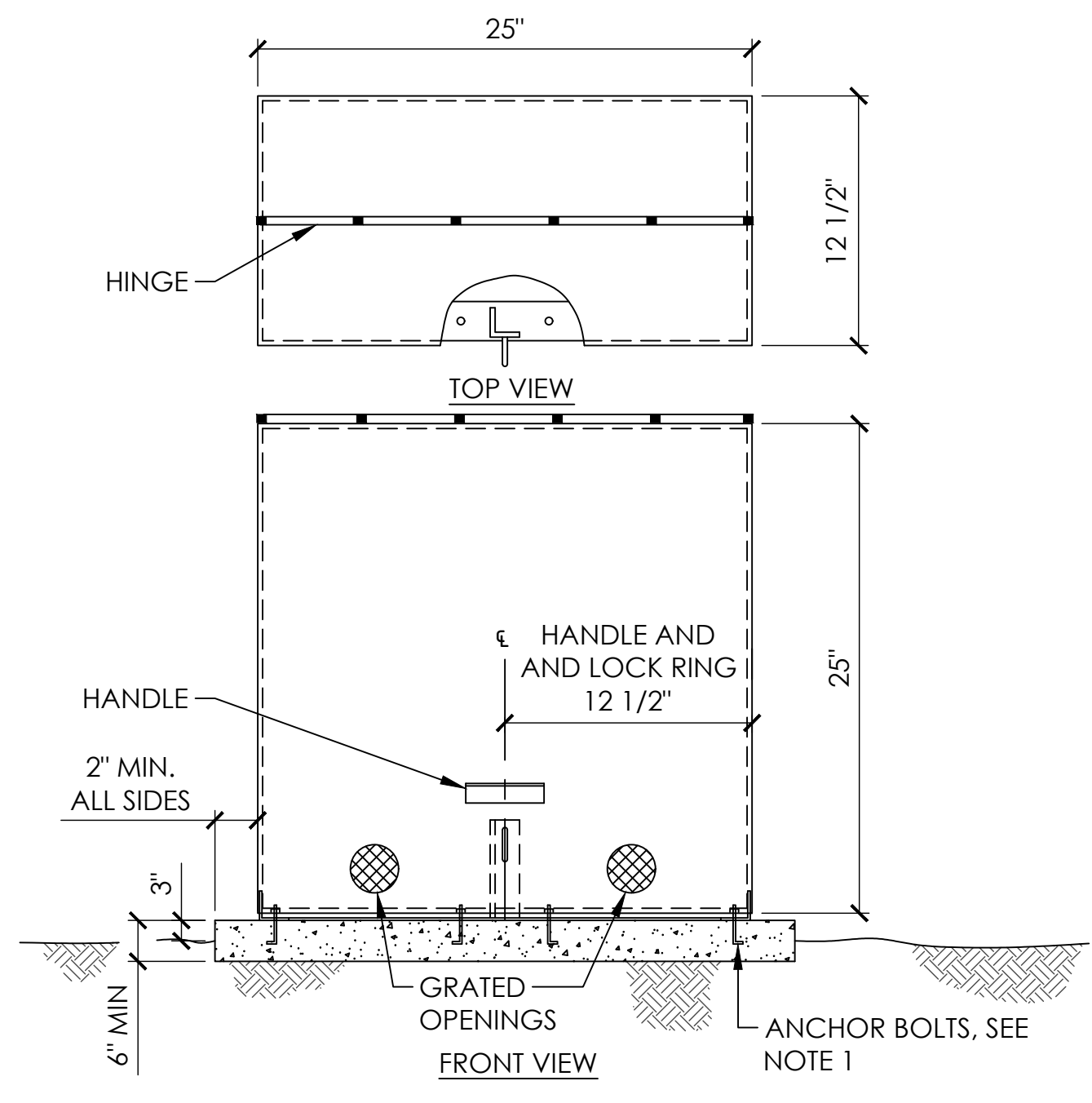

NOTES:
1. CABINET SHALL BE MOUNTED WITH 3/8"x4" 'J' BOLTS (TYP. OF 6).

BACKFLOW DEVICE ENCLOSURE (2) NTS C4.1

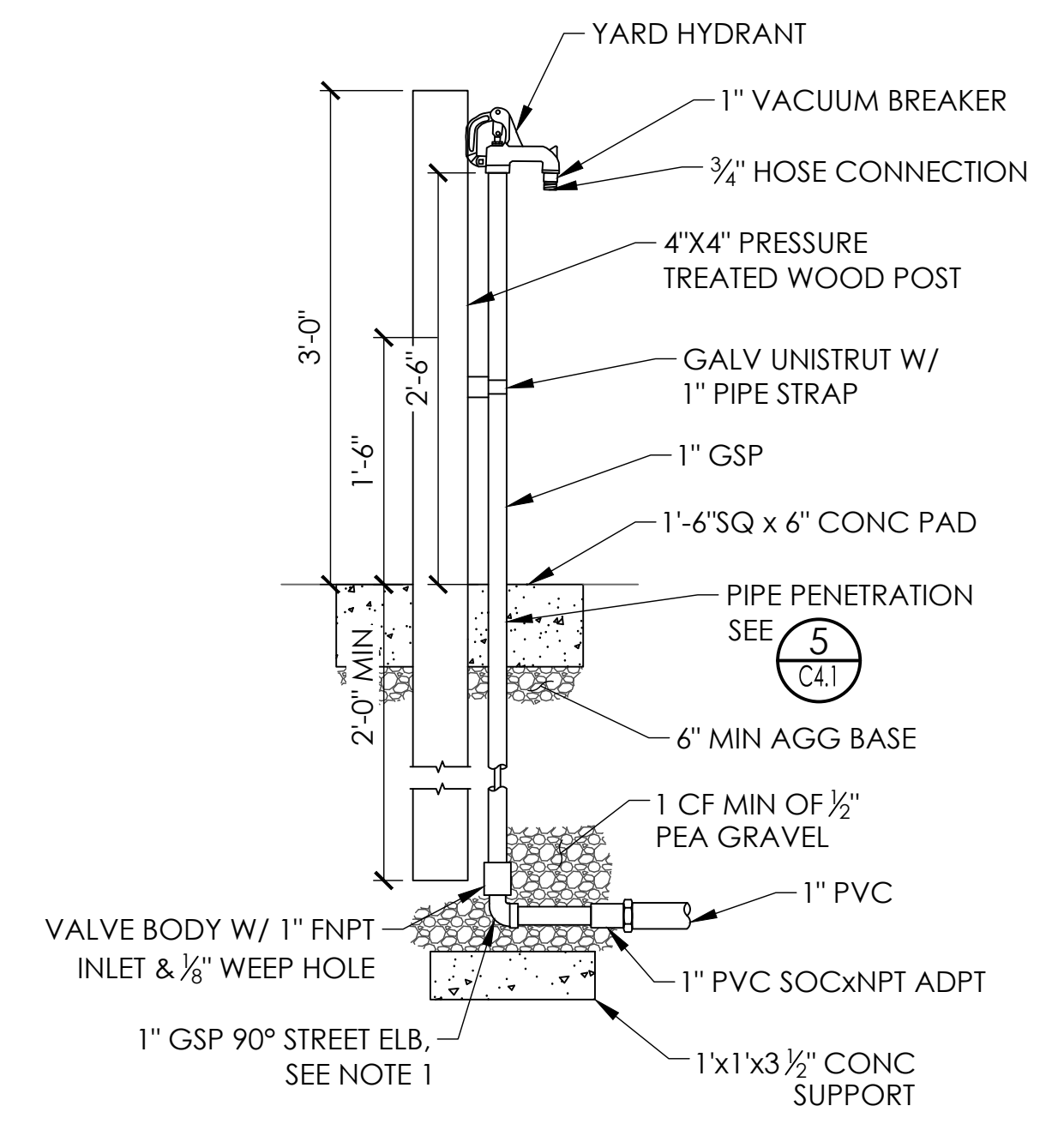

NOTES:
1. IF 1 IN PVC SUPPLY IS NOT HORIZ, AN ADDITIONAL 90° STREET ELB SHALL BE PROVIDED TO PLUMB RISER.
2. ALL GALVANIZED PIPE AND FITTINGS UNDERGROUND SHALL BE DOUBLE WRAPPED W/ 20MM PVC PIPE WRAP.

HOSE BIB DETAIL (3) NTS C4.1

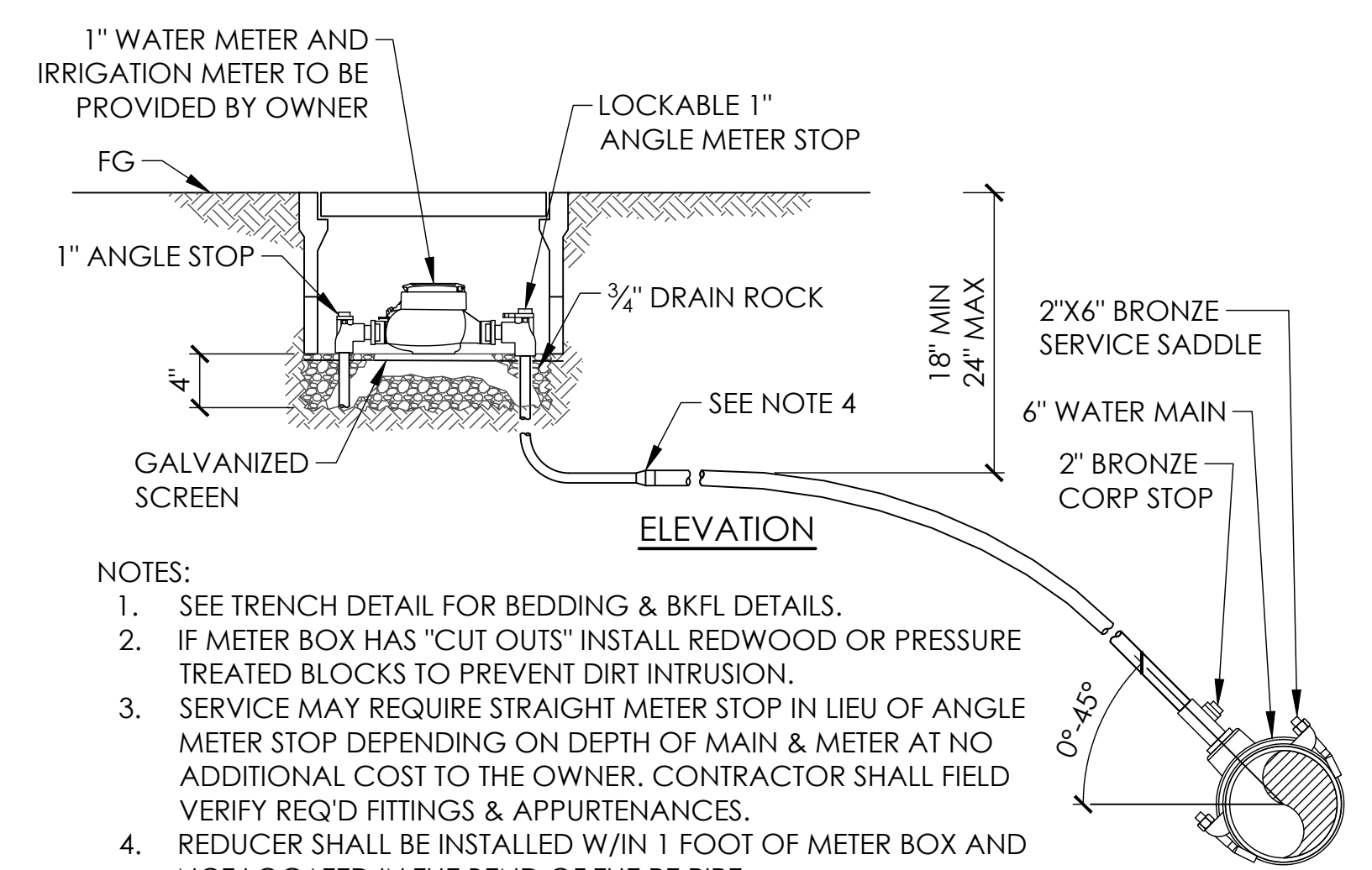
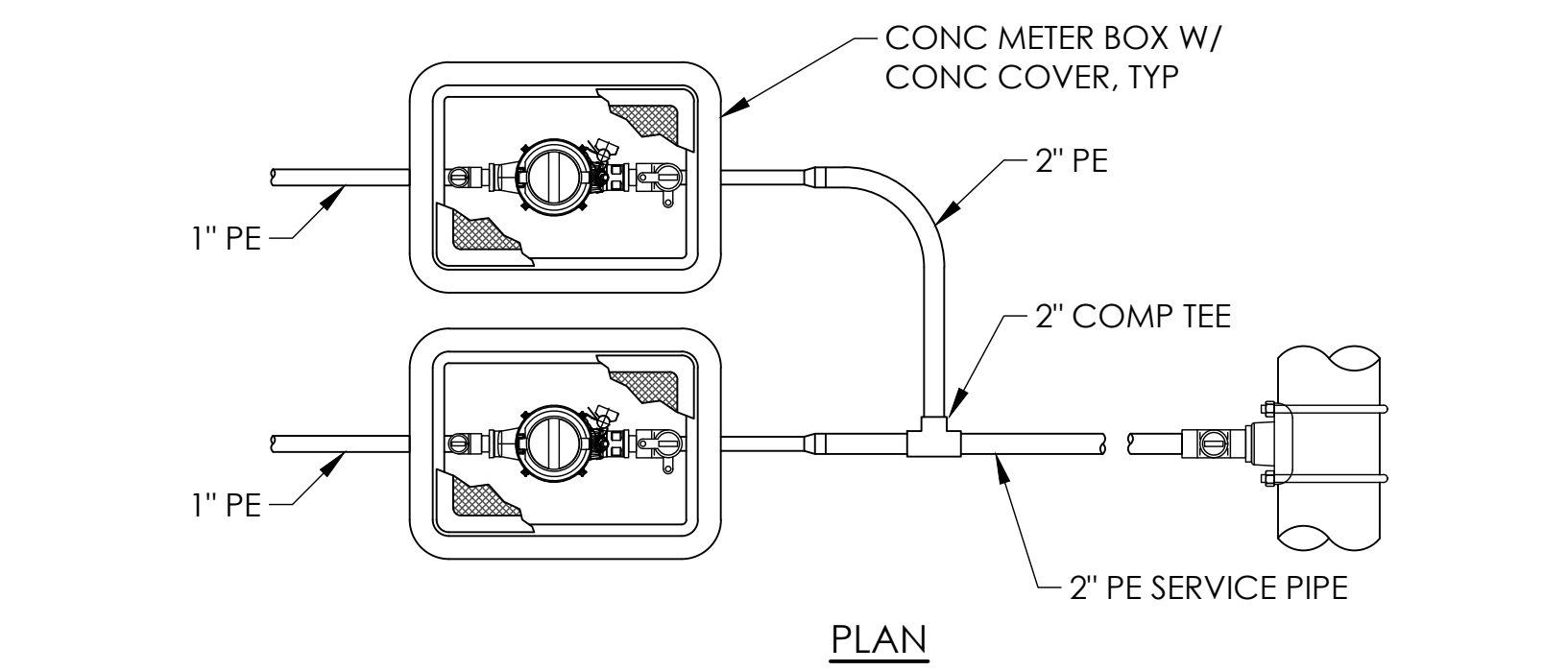

NOTES:
1. SEE TRENCH DETAIL FOR BEDDING & BKFL DETAILS.
2. IF METER BOX HAS "CUT OUTS" INSTALL REDWOOD OR PRESSURE TREATED BLOCKS TO PREVENT DIRT INTRUSION.
3. SERVICE MAY REQUIRE STRAIGHT METER STOP IN LIEU OF ANGLE METER STOP DEPENDING ON DEPTH OF MAIN & METER AT NO ADDITIONAL COST TO THE OWNER. CONTRACTOR SHALL FIELD VERIFY REQ'D FITTINGS & APPURTENANCES.
4. REDUCER SHALL BE INSTALLED W/IN 1 FOOT OF METER BOX AND NOT LOCATED IN THE BEND OF THE PE PIPE
5. PE PIPE SHALL HAVE A FLANGED 304 SS TUBING INSERT SUITABLE FOR HDPE PIPE AND COMPRESSION FITTINGS.
6. ALL WATER PIPE SHALL BE SDR 9 CTS 200 PSI FLEX PIPE.

WATER SERVICE CONNECTION (4) NTS C4.1

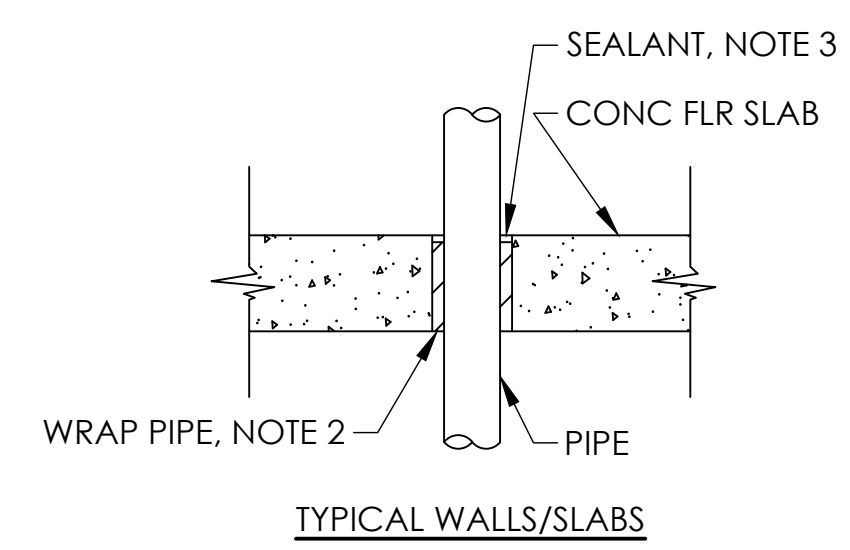

NOTES:
1. CORE DRILL LOCATIONS SHALL BE DETERMINED BY CONTR DURING REINF PLACEMENT TO AVOID CONFLICT. CONC REINF SHALL NOT BE CUT.
2. PIPE SHALL BE WRAPPED W/ 6 IN WIDE WHITE CAP POLY FOAM TAPE, OR EQUAL. WRAP 1/2 IN MIN THICK W/ SCORED LINE NEAR FG
3. REMOVE TOP OF FOAM WRAP @ SCORE. FILL VOID W/ POLYURETHANE SEALANT. PROVIDE SMOOTH PROFILE FROM CONC FLR TO PIPE.

PIPE PENETRATION SEAL (5) NTS C4.1

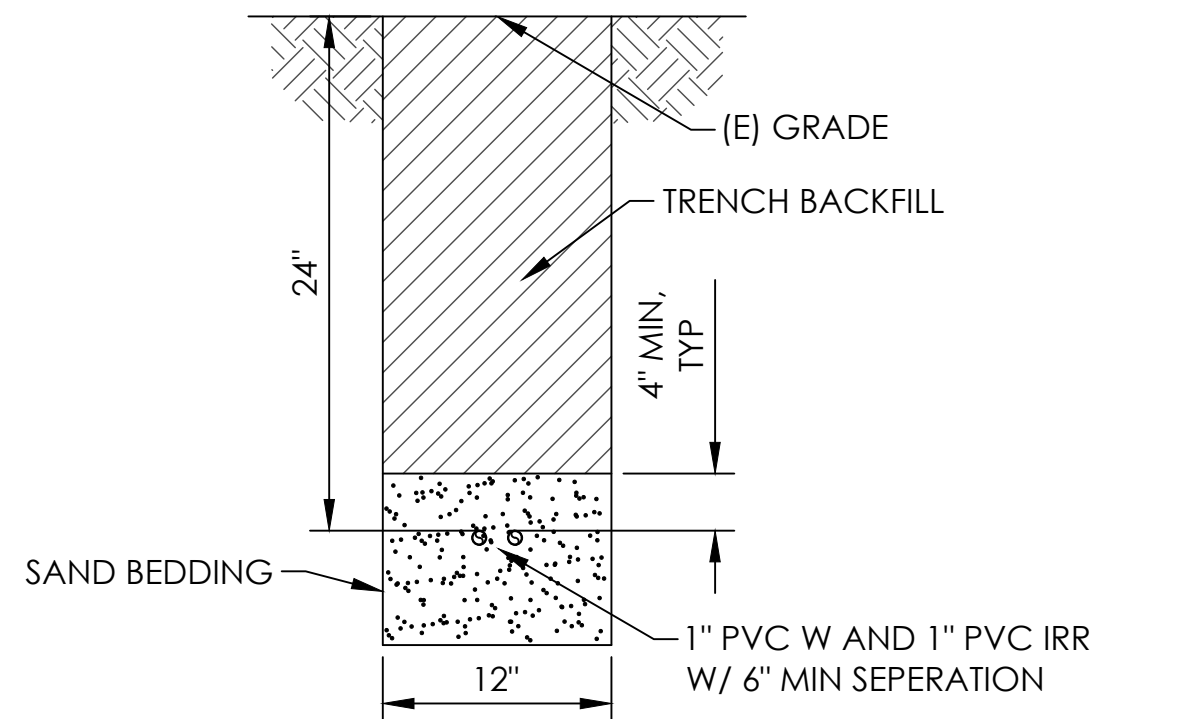

NOTES:
1. THE BOTTOM OF TRENCHES SHALL BE TRUE TO GRADE AND FREE OF PROTRUDING STONES, ROOTS, OR OTHER MATTER WHICH WOULD PREVENT PROPER BEDDING OF PIPE.
2. BACKFILL MATERIAL SHALL BE: NATIVE MATERIAL, AND FREE FROM DEBRIS, VEGETATIVE MATERIAL, ROCKS OVER ONE (1) INCH IN DIAMETER, AND OTHER COARSE UNDESIRABLE MATERIAL.
3. PLACE BACKFILL MATERIALS IN SIX (6) INCH LAYERS AND COMPACT BY JETTING OR TAMPING TO A MINIMUM COMPACTION OF 90 PERCENT OF ORIGINAL SOIL DENSITY.
4. BACKFILL ONLY AFTER PIPING HAS BEEN TESTED, INSPECTED AND APPROVED.
5. A WATER PRESSURE TEST SHALL BE PERFORMED ON ALL PRESSURE MAINS BEFORE ANY COUPLINGS, FITTINGS, AND/OR VALVES ARE CONCEALED. THE TEST SHALL BE PERFORMED AT A CONSTANT PRESSURE OF 125 PSI FOR A DURATION OF THREE (3) HOURS.
6. ALL TRENCH SETTLEMENTS SHALL BE BROUGHT BACK TO ORIGINAL FINISH GRADE. THE CONTRACTOR SHALL REPAIR AND REPLACE ALL LAWN, PLANTED, HARDSCAPED, AND OTHER PAVEMENT AREAS DAMAGED DUE TO TRENCH SETTLEMENT.

BACKFILL AND PIPE BEDDING DETAIL (6) NTS C4.1

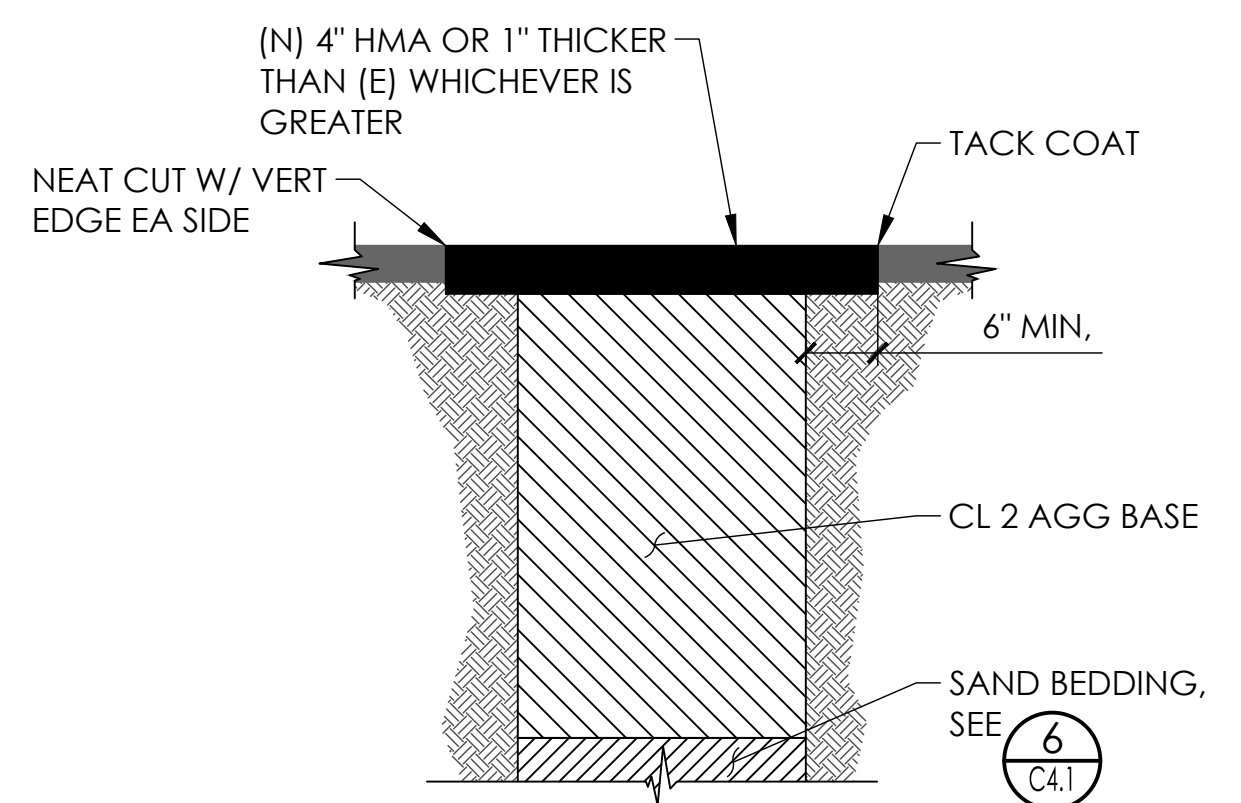

NOTES:
1. CLASS "A3" BKFL SHALL BE USED IN ALL PAVED AREAS.

CLASS A3 BACKFILL DETAIL (7) NTS C4.1

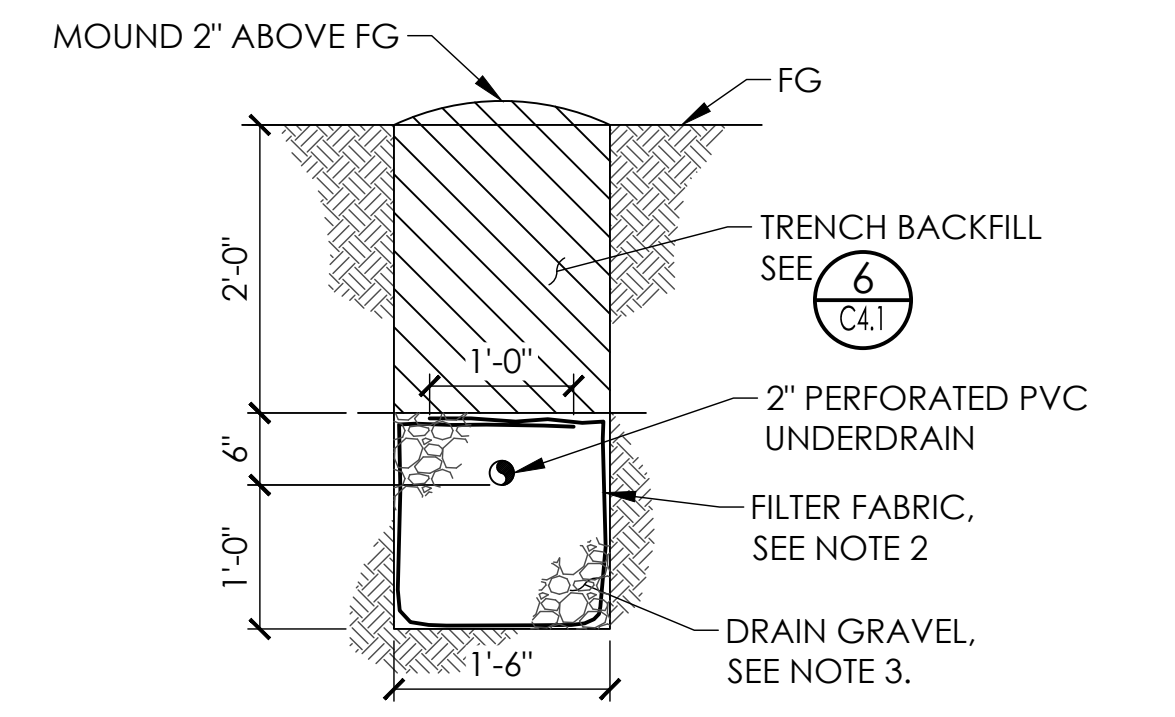

NOTES:
1. TERMINATE TRANSPORT PIPE 4" INSIDE OF THE GRAVELLESS CHAMBER END CAP. PLACE 1/4 CUBIC FOOT OF PEA GRAVEL OR CRUSHED ROCK BELOW INVERT OF THE TRANSPORT PIPING INSIDE THE CHAMBER TO LIMIT SPLASHING OF THE INFLUENT.
2. WRAP TRENCH WITH MIRAFI 160N GEOTEXTILE FABRIC, OR APPROVED EQUAL.
3. GRAVEL OR SIMILAR FILTER MATERIALS, CLEAN IN APPEARANCE AND VARYING IN SIZE FROM 3/4" INCH TO 2 1/2".

LEACH TRENCH DETAIL (8) NTS C4.1

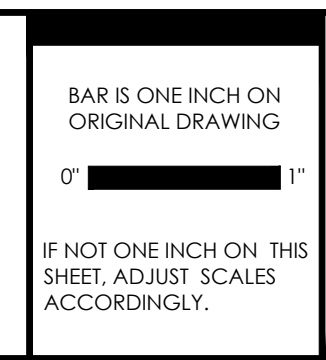

REVISIONS		
NO	DATE	DESCRIPTION

PACE ENGINEERING

DES: TJ/RT CKD: TJ/JC JOB NO. 0306.45
DRN: RT DATE: 03/31/23

SIGNED

BURNEY WATER DISTRICT
WASHBURN BUE DOG PARK

DETAILS

SHEET

C4.1

PG 6 OF 6