

BURNEY WATER DISTRICT

SEWER SYSTEM MANAGEMENT PLAN

Revised 2022/2023 by District Staff and PACE Engineering
Original Document Completed in 2017 by PACE Engineering

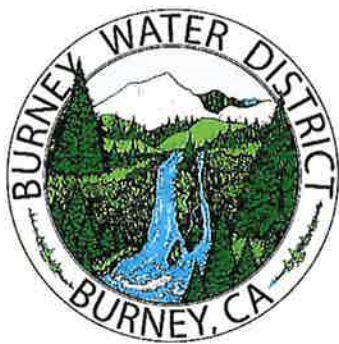

Table of Contents

Introduction	1
Background.....	1
System Overview	2
Element 1: Goals	3
1.1 Regulatory Requirements for Goals Element.....	3
1.2 Goals Discussion	3
Element 2: Organization.....	4
2.1 Regulatory Requirements for Organization Element.....	4
2.2 Organization Discussion	5
2.2.1 Description of Responsibilities	6
2.2.2 Legally Responsible Official	7
2.2.3 Responsibility for SSMP Implementation	7
2.2.4 Chain of Communication for Responding to an SSO	7
2.2.5 Chain of Communication for Reporting an SSO.....	8
Element 3: Legal Authority	12
3.1 Regulatory Requirements for Legal Authority Element	12
3.2 Legal Authority Discussion.....	13
3.2.1 Sewer Ordinance No. 90-01.....	13
Element 4: Measures and Activities	15
4.1 Regulatory Requirements for Measures and Activities	15
4.2 Measures and Activities Discussion.....	16
4.2.1 Map.....	16
4.2.2 Preventive Maintenance.....	16
4.2.3 Condition Assessment	19
4.2.4 Equipment.....	20
4.2.5 Training.....	21
Element 5: Design and Construction Standards	22
5.1 Regulatory Requirements for Design and Construction Standards.....	22
5.2 Design and Construction Standards Discussion	22
5.2.1 Installation, Rehabilitation, and Repair.....	23
5.2.2 Inspection and Testing of New and Rehabilitated Facilities	23

Element 6: Sanitary Sewer Overflow Emergency Response Plan	24
6.1 Regulatory Requirements for Overflow Emergency Response Plan.....	24
6.2 Overflow Emergency Response Plan Discussion	25
6.2.1 SSO Notification.....	25
6.2.2 SSO Response	26
6.2.3 SSO Reporting.....	26
6.2.4 SSO Impact Mitigation	26
Element 7: Fats, Oils, and Grease Control Program.....	27
7.1 Regulatory Requirements for FOG Control Program	27
7.2 FOG Control Program Discussion.....	28
7.2.1 Public Education Outreach Program.....	28
7.2.2 Disposal of FOG	29
7.2.3 Legal Authority	29
7.2.4 Requirements for Grease Removal Devices	30
7.2.5 Authority to Inspect	33
7.2.6 Cleaning Schedule for Identified FOG Prone Sewer Segments.....	33
7.2.7 Source Control Measures	34
Element 8: Capacity Management.....	35
8.1 Regulatory Requirement for Capacity Management	35
8.2 Capacity Management Discussion.....	36
8.2.1 System Evaluation and Capacity Assessment.....	36
8.2.2 Capacity Assurance Plan.....	36
Element 9: Monitoring, Measurement, and Program Modifications.....	38
9.1 Regulatory Requirements for Monitoring, Measurement, and Program Modifications Element.....	38
9.2 Monitoring, Measurement, and Program Modifications Discussion.....	38
Element 10: SSMP Audits.....	40
10.1 Regulatory Requirements for the SSMP Audits Element	40
10.2 SSMP Audit Discussion	40
Element 11: Communication Plan.....	41
11.1 Regulatory Requirements for the Communication Plan Element.....	41
11.2 Communication Plan Discussion.....	41

TABLES

Table 2-1 – SSO Notification and Reporting Requirements	10
Table 2-2 – Contact Numbers for District SSO Chain of Communication.....	11

FIGURES

Figure 2-1 – Organization Chart	5
Figure 2-2 – SSO Responding Procedures Flow Chart.....	8
Figure 2-3 – SSO Reporting Procedures.....	9

APPENDICES AT END OF TEXT

Appendix A	Names and Contact Information of Current Staff
Appendix B	Sanitary Sewer Overflow Emergency Response Plan
Appendix C	City of Redding Standard Specifications and Details for Design and Construction of Wastewater Collection Facilities
Appendix D	Revision Records

ABBREVIATIONS

BMP	Best Management Practice
BWD	Burney Water District
CCTV	Closed-Circuit Television
CIP	Capital Improvement Plan
CIWQS	California Integrated Water Quality System
District	Burney Water District
FOG	Fats, Oils, and Grease
GIS	Geographic Information Systems
IIPP	Injury and Illness Prevention Plan
MRP	Master Reclamation Permit
NPDES	National Pollution Discharge Elimination System
OES	Office of Emergency Services
PACE	PACE Engineering, Inc.
SMP	Sewer Master Plan
SSMP	Sewer System Management Plan
SSO	Sanitary Sewer Overflow
SSOERP	Sanitary Sewer Overflow Emergency Response Plan
SWRCB	State Water Resources Control Board
WDR	Waste Discharge Requirements
WWTP	Wastewater Treatment Plant

Introduction

This introduction section provides background information on the purpose and organization of the Sewer System Management Plan (SSMP) and provides a brief overview of the Burney Water District (BWD or District) area and sewer system.

Background

This SSMP has been prepared in compliance with requirements of the State Water Resources Control Board's General Waste Discharge Requirements (WDR), Order No. 2006-0003-DWQ (statewide WDR) and exec 2013-0058.

The State Water Resources Control Board (SWRCB) acted at its meeting on May 2, 2006 to require all public wastewater collection system agencies in California with greater than one mile of sewers to be regulated under the statewide WDR. The SWRCB action, which applies to BWD, also mandates the development of an SSMP and the reporting of Sanitary Sewer Overflows (SSO) using an electronic reporting system, CIWQS.

PACE Engineering, Inc. (PACE), together with BWD staff prepared the current SSMP Update in February 2017. The intent of this SSMP update is to meet requirements of the Statewide WDR and be a meaningful document the District refers to for management of the wastewater collection system. The organization of this document is consistent with SWRCB requirements. The SSMP includes eleven elements, as follows:

1. Goals
2. Organization
3. Legal Authority
4. Operation and Maintenance
5. Design and Performance
6. Overflow Emergency Response Plan
7. Fats, Oils, and Grease (FOG) Control Plan
8. System Evaluation and Capacity Assurance Plan
9. Monitoring, Measurement, and Program Modifications

10. SSMP Audits

11. Communication Plan

System Overview

BWD is classified as a Special District and is located in northeastern Shasta County. BWD provides potable water, sewer, pool, and parks service to a community with a population of approximately 3,000 people.

BWD's sewer system consists of approximately 22 miles of pipe, ranging from 6 to 15 inches in diameter, and two lift stations (Main Lift Station on Black Ranch Road and Bartel Lift Station on Bartel Street). BWD does not receive wastewater flow from areas outside of the District Boundary.

BWD maintains its own sewer system and occasionally utilizes contract services for specialized maintenance, such as pump rebuilding or electrical repairs.

Element 1: Goals

This SSMP element identifies goals BWD has established for the management, operation, and maintenance of the sewer system and discusses the role of the SSMP in supporting these goals. These goals provide focus for BWD staff to continue high-quality work and to implement improvements in the management of the District's wastewater collection system. This section fulfills the Goals requirement (Element 1) of the SWRCB SSMP requirements.

1.1 Regulatory Requirements for Goals Element

The summarized requirements for the Goals Element of the SSMP are as follows:

The collection system agency must develop goals to properly manage, operate, and maintain all parts of its wastewater collection system in order to reduce and prevent SSOs, as well as to mitigate any SSOs that may occur.

1.2 Goals Discussion

The mission of BWD is to provide a safe and reliable water supply, environmentally safe disposal of wastewater, and responsible governance of pools and parks. In support of this mission, BWD has developed the following goals for operation and maintenance of the sewer system:

1. Avoid sanitary sewer overflows and respond to sanitary sewer overflows quickly and mitigate impact of the overflow to prevent public health hazards.
2. Provide excellent customer service through efficient system operation and effective communication strategies. Protect the investment in the collection system by maintaining adequate capacities and extending the useful life span of the system.
3. Avoid unnecessary damage to public and private property.
4. Use funds available for sewer operation in the most efficient manner and establish a capital improvement fund for the sewer system.
5. Convey wastewater to ponds with a minimum amount of infiltration, inflow, and exfiltration.
6. Provide adequate capacity to convey peak flows.
7. Perform all operations in a safe manner to avoid personal injury and property damage.
8. Provide training for Wastewater Collection staff.
9. Meet all applicable regulatory notification and reporting requirements.

Element 2: Organization

The intent of this section of the SSMP is to identify District staff who are responsible for implementing this SSMP, responding to SSO events, and meeting SSO reporting requirements. This section also includes the designation of the Authorized Representative to meet SWRCB requirements for completing and certifying spill reports. This section fulfills the Organization requirement (Element 2) of the SWRCB SSMP requirements.

2.1 Regulatory Requirements for Organization Element

The summarized requirements for the Organization Element of the SSMP are as follows:

The collection system agency's SSMP must identify:

1. The name of the responsible or authorized representative.
2. The names and telephone numbers for management, administrative, and maintenance positions responsible for implementing specific measures in the SSMP program. Include lines of authority as shown in an organization chart or similar document with a narrative explanation.
3. The chain of communication for reporting SSOs from receipt of a complaint or other information, including the person responsible for reporting SSOs to the State and Regional Water Board and other agencies, if applicable [such as County Health Officer, County Environmental Health Agency, Regional Water Quality Control Board, and/or State Office of Emergency Services (OES)].

2.2 Organization Discussion

This section discusses the organization and roles of wastewater staff, the authorized representative to the SWRCB, and key staff responsible for implementing and maintaining the SSMP. Names and contact information for all current staff is available in Appendix A.

Figure 2-1 – Organization Chart

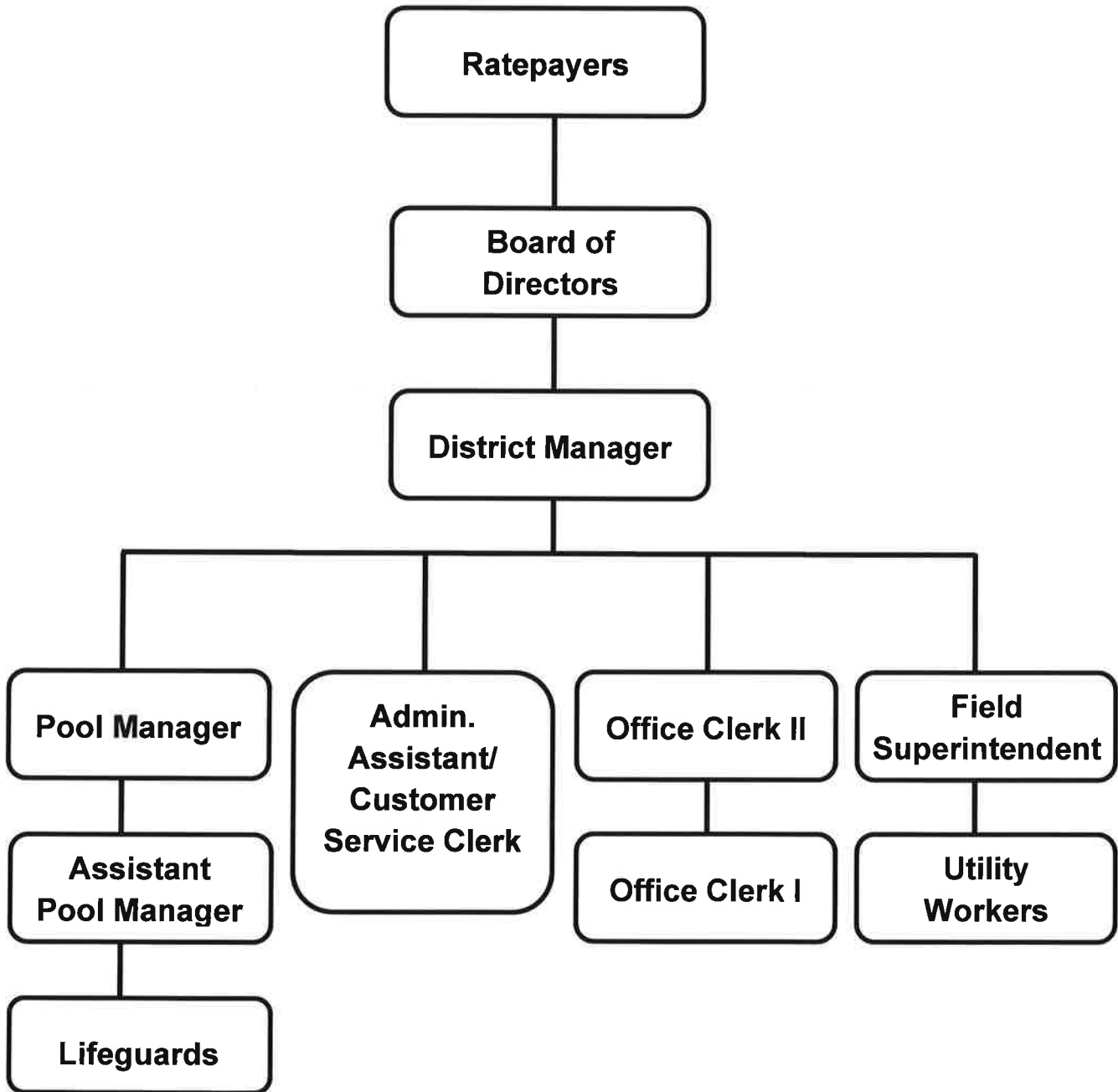

2.2.1 Description of Responsibilities

Note: Only responsibilities relevant to sewer system operations are described below:

Board of Directors

Establish policy.

District Manager

Plans, organizes, directs, performs, and supervises all work activities of BWD, including maintenance and repairs of sewer infrastructure. The District Manager advises the Board of Directors on public works and/or engineering matters. The District Manager confers with contractors, engineers, and members of the general public on construction and maintenance problems and procedures. The District Manager prepares the budget, while the Board of Directors approves the budget. The District Manager prepares cost estimates and obtains approval of the Board of Directors for all impending public work other than normal repairs and maintenance. The District Manager aids contractors with plans and specifications for public work projects if approved by the Board of Directors.

Field Superintendent

Responsible for plant operations and collection system maintenance. The Field Superintendent supervises utility operators, schedules work assignments, and maintains records of assigned projects, supplies, and equipment. The Field Superintendent is responsible for maintaining written documents of all public works, records, maintenance schedules, and regulatory reports. The Field Superintendent also investigates sewer-related complaints from the general public and estimates needed equipment and equipment maintenance.

Utility Worker

Works as a member of a field maintenance crew to clean, unplug, and repair sewer lines and inspect lift stations. Utility Workers locate and raise manholes and operate power equipment. Utility Workers are responsible for scheduling sewer

cleaning with outside contractors upon Board approval. Utility Workers are first responders who are responsible for underground service alerts.

2.2.2 Legally Responsible Official

The District's authorized representative in all wastewater collection system matters is the District Manager. The District Manager is authorized to certify electronic spill reports submitted to the SWRCB and can submit SSO reports to appropriate government agencies. The Field Superintendent and Utility Worker positions can also perform these functions when authorized by the District Manager. The name and contact information of the current District Manager who is the legally responsible official is included in Appendix A.

2.2.3 Responsibility for SSMP Implementation

The District Manager is responsible for implementing and maintaining all elements of this SSMP.

2.2.4 Chain of Communication for Responding to an SSO

The chain of communication for responding to an SSO is shown in Figure 2-2. Contact information for the chain of communication is shown in Table 2-2. An overview of BWD's overflow response procedure can be found in Element 6: Sanitary Sewer Overflow Emergency Response Plan. Detailed information is given in the District's complete Sanitary Sewer Overflow Emergency Response Plan in Appendix B.

Figure 2-2 – SSO Responding Procedures Flow Chart

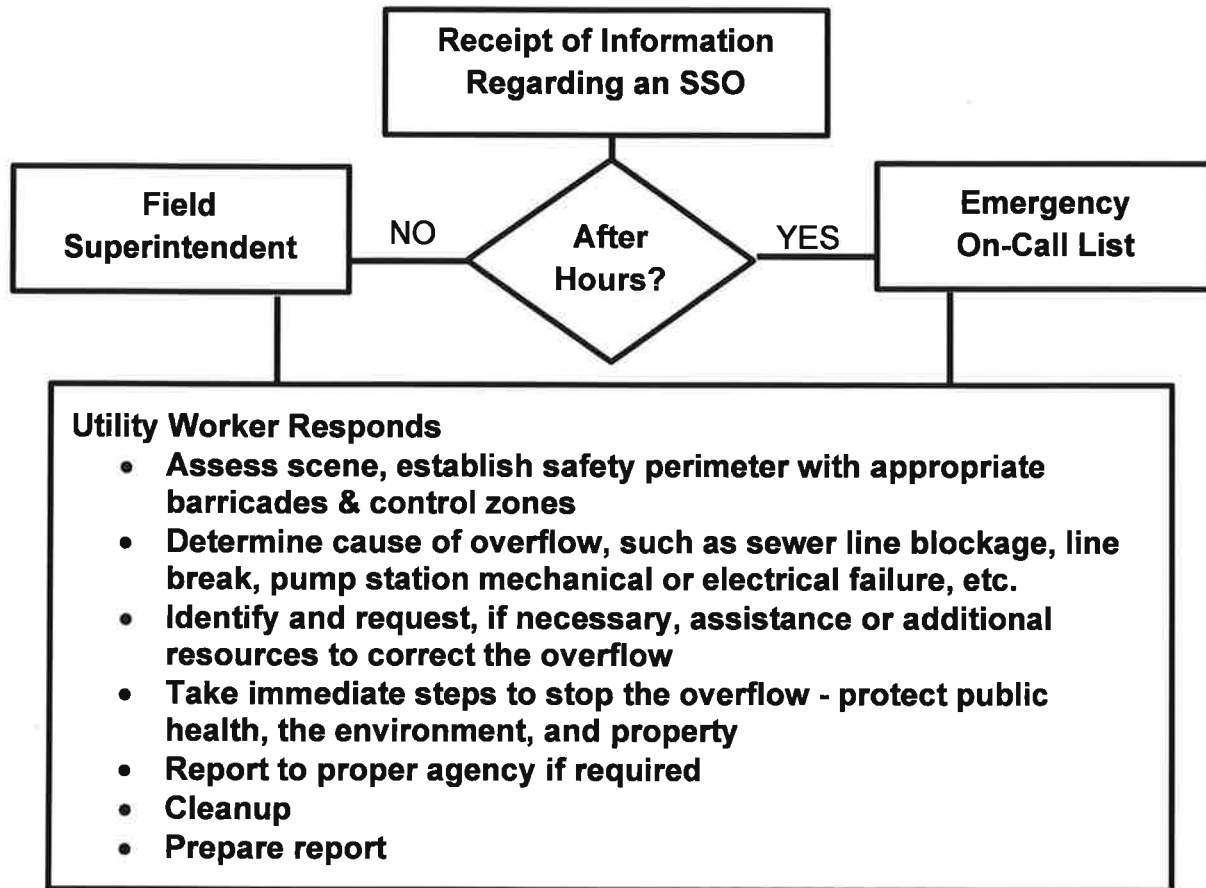

2.2.5 Chain of Communication for Reporting an SSO

Categorizing the chain of responsibilities for reporting SSOs to the various required regulatory agencies is shown in Figure 2-3, with reporting requirements indicated in Table 2-1. All SSOs are required to be reported to the SSO database regardless of the SSO volume. An overview of SSO reporting can be found under Element 6: Sanitary Sewer Overflow Emergency Response Plan. Detailed information is given in the District’s complete Sanitary Sewer Overflow Emergency Response Plan in Appendix B.

Figure 2-3 – SSO Reporting Procedures

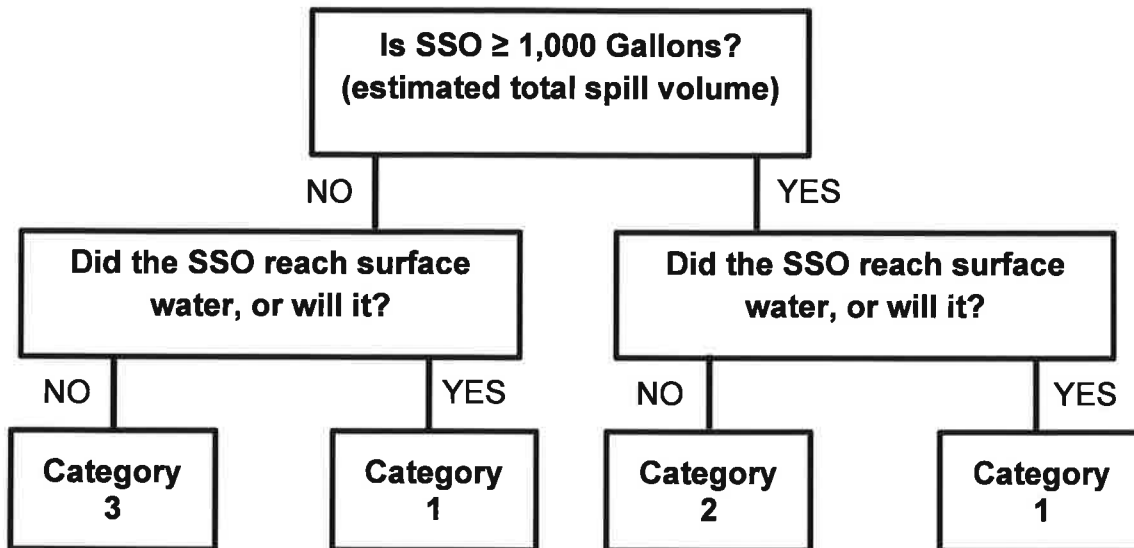

Table 2-1 – SSO Notification and Reporting Requirements

Category	Notification Contact	Notification Time Frame	Reporting
1	Office of Emergency Services	Within 2 hours	Submit draft report within 3 business days of becoming aware of the SSO and certify within 15 calendar days of SSO end date
	Shasta County Health Department		
	Department of Fish and Game		
	Regional Water Quality Control Board		
	CIWQS	Within 48 hours	Conduct water quality sampling after initial SSO notification for any Category 1 SSO in which 50,000 gallons or greater are spilled to surface waters
CIWQS	Within 45 calendar days after end date of spill	SSO Technical Report for any Category 1 SSO in which 50,000 gallons or greater are spilled to surface waters	
2	Shasta County Health Department	Within 2 hours	Submit draft report within 3 business days of becoming aware of the SSO and certify within 15 calendar days of the SSO end date
3	No Notification Required	N/A	Submit certified report within 30 calendar days of the end of the month in which the SSO occurred
N/A	CIWQS	Within 30 calendar days of the end of the month or, if reporting quarterly, the quarter in which no SSOs occurred	"No Spill" Certification
N/A	CIWQS	Every 12 months	Update and certify Collection System Questionnaire

Table 2-2 – Contact Numbers for District SSO Chain of Communication

Contact	Position	Office Phone Number	Work Cell Phone
David Zevely	District Manager	530-335-3582	530-238-7833
Mike Skelly	Field Superintendent	530-335-3582	530-238-7774
Willie Lyons	Utility Worker	530-335-3582	530-238-7774
Keith Moore	Utility Worker	530-335-3582	530-238-7774
Valerie Rasmussen	SWRCB	530-224-6130	
Shasta County Health Department		530-225-5073	
Office of Emergency Services (CA State)		800-852-7550	
Department of Fish and Game		530-225-2300	

Element 3: Legal Authority

This element of the SSMP discusses the District's Legal Authority, including its Sanitary Code. This section fulfills the Legal Authority requirement (Element 3) of the SWRCB SSMP.

3.1 Regulatory Requirements for Legal Authority Element

The requirements for the Legal Authority Element of the SSMP are summarized below:

The District must demonstrate, through collection system use ordinances, service agreements, or other legally binding procedures, that it possesses the necessary legal authority to:

1. Prevent illicit discharges into the sanitary sewer system (examples may include but are not limited to storm water, chemical dumping, unauthorized debris, cut roots, etc.).
2. Control infiltration and inflow from satellite collection systems and laterals.
3. Require that mains and laterals be properly designed and constructed including all new and rehabilitated sewer systems and connections.
4. Ensure access for maintenance, inspection, or repairs for portions of the lateral owned or maintained by BWD.
5. Limit the discharge of fats, oils, grease, and other debris that may cause blockages.
6. Enforce any violations of its sewer ordinances.

Refer to BWD current Sewer Ordinance and amendments (if any).

3.2 Legal Authority Discussion

BWD has the legal authority to:

1. Assign responsibility for private laterals.
2. Prevent illicit discharges.
3. Require proper design and construction of mains and laterals.
4. Access facilities owned by the District for maintenance, inspection, and repairs.
5. Limit the discharge of fats, oils, grease, and debris.
6. Enforce the provisions of Sewer Ordinance.

At the time of this SSMP, Sewer Ordinance No. 90-01 is the current Sewer Ordinance. The District intends to update this ordinance, in which case section numbers referenced herein may change and will require updating. Refer to the most current Sewer Ordinance when reviewing BWD legal authority.

3.2.1 Sewer Ordinance No. 90-01

BWD Sewer Ordinance No. 90-01 was adopted by the District Board to establish rules and regulations pertaining to the use, maintenance, and charges for the sewage works within the boundaries of BWD to protect the health, safety, and general welfare of the citizens of the District.

Responsibility for Maintenance Laterals

BWD Sewer Ordinance No. 90-01 Section 9.02 establishes the owner as the responsible party for ownership and maintenance of the service lateral and cleanouts beyond the Shasta County right-of-way.

Prevention of Illicit Discharges

BWD Sewer Ordinance No. 90-01 Section 10.04 states that if substances are discharged and found to be in violation of Section 10 of the Ordinance, the owner shall immediately cease discharging, shall be subject to penalties as outlined, and shall bear the cost of all laboratory charges.

Proper Design and Construction of Sewers and Connections

BWD Sewer Ordinance No. 90-01 Section 3 contains all regulations required by the District as to material and manner of construction of the sewer system and connections.

Access for Maintenance, Inspection, and Repairs

BWD Sewer Ordinance No. 90-01 Section 9.01 states BWD shall own, operate, and maintain all sewer mains. BWD will exercise reasonable diligence and care to provide continuous operation of its sewage disposal facilities. The District shall have access to cleanouts at all times.

Limit Discharge of Fats, Oils, Grease, and Debris

BWD Sewer Ordinance No. 90-01 Section 5 requires “grease traps or interceptors be installed in all establishments which handle, prepare, cook, or serve foods or produce, or when in the opinion of the District Manager, an establishment may introduce grease into the sanitary sewer in quantities that can affect the proper functioning of the sewage works.”

Section 10 prohibits the discharge of any water or waste containing fats, wax, grease, or oils, whether emulsified or not, in excess of 100 mg/L or containing substances which may solidify or become viscous at temperatures below 60 degrees Fahrenheit.

Enforcement Measures

BWD Sewer Ordinance No. 90-01 Section 11 states all persons who are subject to the provisions of this Ordinance are also subject to the penalties as set forth in Section 11 for violations of this Ordinance.

Element 4: Measures and Activities

This element of the SSMP discusses the District's operation and maintenance program. This section fulfills the Operation and Maintenance Program requirement (Element 4) of the SWRCB SSMP.

4.1 Regulatory Requirements for Measures and Activities

The requirements for the Measures and Activities Element of the SSMP are summarized below:

Maps

The District must maintain an up-to-date map of the sanitary sewer system, showing all gravity line segments, manholes, pumping facilities, pressure pipes, valves, and applicable storm water conveyance facilities.

Preventative Maintenance

The District must describe routine preventative operation and maintenance activities by staff and contractors, including a system for scheduling regular maintenance and cleaning of the sanitary sewer system with more frequent cleaning and maintenance targeted at known problem areas. The preventative maintenance program should have a system to document scheduled and conducted activities, such as work orders.

Condition Assessment

The District must develop a rehabilitation and replacement plan to identify and prioritize system deficiencies and implement short-term and long-term rehabilitation actions to address each deficiency. The program should include regular visual and TV inspections of manholes and sewer pipes and a system for ranking the condition of sewer pipes and scheduling rehabilitation. Rehabilitation and replacement should focus on sewer pipes that are at risk of collapse or prone to more frequent blockages due to pipe defects. Finally, the rehabilitation and replacement plan should include a capital improvement plan that addresses proper management and protection of infrastructure assets. The plan shall include a time schedule for implementing the short- and long-term plans, plus a schedule for developing the funds needed for the capital improvement plan.

Equipment

The District must provide equipment and replacement part inventories, including identification of critical replacement parts.

Training

The District must provide training on a regular basis for staff in sanitary sewer system operation and maintenance and require contractors to be appropriately trained.

4.2 Measures and Activities Discussion

The section summarizes the measures and activities of BWD to manage the sewer system. For a detailed description of these activities performed at the wastewater treatment plant (WWTP), refer to Operation and Maintenance Manual for the Water Pollution Control Facilities completed by CDM Inc., October 1975 (O&M Manual). This will soon be updated upon completion of the WWTP Improvement Project currently under construction.

4.2.1 Map

Sewer system maps are on file at the BWD office. PACE and BWD created an updated Water and Sewer Atlas, which was most recently revised in 2021. BWD intends to convert their sewer mapping to web-based Geographic Information Systems (GIS) in the near future. The District Manager is responsible for updating maps as facilities are added and rehabilitated and as corrections are identified through field work.

4.2.2 Preventive Maintenance

Pipeline Cleaning Program

BWD received grant funding to complete cleaning and closed-circuit television (CCTV) inspection of most of the collection system in 2016. BWD utilizes a trailer-mounted high-pressure sewer jetter to perform pipeline cleaning on the sanitary sewer system throughout the year. BWD is in the process of implementing a pipeline cleaning program to include a rotating schedule of cleaning. The goal of the rotating schedule is to clean the entire system over a three- to five-year period. Specific sections of the

system will be targeted for cleaning each year, then rescheduled again for cleaning in three to five years. BWD maintains records of all scheduled or emergency pipeline cleaning by way of request for service forms, call out forms, or daily field staff work reports at the BWD office. These records will be used to identify possible problem areas in the system and to maintain compliance with regulatory agencies.

Pipeline Monitoring Program

The funding BWD received launched the Pipeline Monitoring Program along with the aforementioned Pipeline Cleaning Program in 2016. A sewer video camera was used to inspect the majority of collection system pipelines after high-pressure cleaning to identify areas of the system that may require increased inspection and preventive maintenance activity or future repair or replacement. This should assist in reducing the need for emergency maintenance and possible SSO issues. Inspection and cleaning will continue in the future, and areas deemed as potential problem areas, or where problems have already been identified, will be assigned a work order. BWD staff will repair or replace the affected portion of the system identified in the work order. All records of this maintenance will be documented and kept on file.

Preventive Root Maintenance Program

As part of the ongoing Pipeline Cleaning and Monitoring Programs, areas of the sanitary sewer system that are found to have root intrusion will be identified.

Depending on the severity of the root intrusion, preventive maintenance activity frequency may be increased or the affected portion of the system may require repair or replacement. BWD has not yet adopted an annual chemical root control program but will consider this option based on the findings of the Pipeline Cleaning and Monitoring Programs.

Fats, Oils, and Grease (FOG) Program

BWD has residential and commercial connections to the sanitary sewer system. There are a number of restaurants and community halls in town with fully functional kitchens. Only a small number have grease traps installed. As part of this SSMP update, BWD

has developed a FOG Control Program and intends to implement it with adoption of the SSMP, see Element 7.

Lift Station Preventive Maintenance Program

BWD performs annual preventive maintenance and/or cleaning of the three lift stations in the system. Maintenance can include pressure washing the wet wells, visual inspections of the tank and all equipment, occasional addition of an environmentally friendly degreasing agent, and documenting any potential problems or damage requiring repair or replacement. Work orders are issued as needed, and BWD staff repair or replace the affected portions of the lift stations. All records of this maintenance are documented and kept on file.

System Blind Spots

There are a number of system blind spots in the BWD sanitary sewer system where an SSO could go unnoticed for a significant amount of time. BWD field staff routinely perform visual inspections of these locations in an attempt to identify flow blockages and other issues before they become an SSO. The following manholes are inspected weekly for backups:

- 184A
- 88
- 92I
- 271
- 66
- 202
- 5B
- 82A
- 209
- 41B
- 63A

Work Order System

BWD is in the process of implementing an electronic work order system to allow for documentation and the tracking of progress and potential hot spots within the system. A work order will be written for all repairs and maintenance done on the system prior to work being completed, with the exception of a system emergency where a work order will be written after the initial emergency has concluded or all repairs have been completed.

Work order records will be used to determine how much of the system was cleaned, repaired, or replaced during a year. The records will also identify the exact location of all work completed on the system and will identify areas more often affected than others.

Customer Complaints

If there is a customer complaint, a work order will be issued to allow BWD staff to investigate the nature of the complaint. The results of this investigation will remain documented at the BWD office. If there is no identifiable problem, this will be documented on the work order and kept on file. If a problem is identified, BWD staff will work to promptly resolve the problem. If the problem is identified in an area that is not property of BWD, the homeowner will be advised of the problem and on the procedures to follow to resolve the problem. If a homeowner does not resolve the problem, BWD may do so with all costs to include labor, materials, permits, and administration fees to be charged back to the homeowner. If the homeowner refuses to pay said costs, legal action and possible termination of services provided by BWD may be pursued to resolve the debt incurred to BWD.

4.2.3 Condition Assessment

BWD has implemented a rehabilitation and replacement program to update, repair, and replace infrastructure that is no longer working at the highest level of efficiency. The capital improvement plan (CIP) is discussed in Element 8, and complete details can be found in the BWD Sewer Master Plan (SMP) completed by PACE in January 2014.

Projects are categorized as immediate-term, near-term, intermediate-term, or long-term projects. Projects will be determined based on the financial impact on BWD. If the yearly allotted budget will not allow for the cost of a repair, and it does not need to be immediately corrected, it will be deemed a long-term project. Long-term projects will also include any rehabilitation or repair that will require the use of finances from an outside source or future revenues.

Significant capital improvements will be addressed as long-term projects. To assist in funding future long-term projects, a sewer capital improvement reserve fund has been set

up to aid in financing future growth-related projects. The District intends to set up another reserve fund for existing equipment replacement when rates have been increased to fund such an account.

The final step of the rehabilitation and replacement plan will be to continually reevaluate areas after rehabilitation has been completed. This will allow for proper maintenance, upkeep, and an estimated time that future repair or replacement may need to take place. It will allow BWD to see from start to completion, the time necessary to make such repairs or replacements and will allow for better estimates of funds needed to continue such projects. It will also allow BWD to evaluate the effectiveness of repairs and replacements to assure optimal efficiency of the system as a whole.

Since completion of the SMP, BWD received funding to launch the Pipeline Monitoring Program. CCTV inspection was completed, following jetting cleaning, to inspect and assess the condition of the entire gravity collection system.

In 2017, PACE and BWD completed a Project Report, which recommended completion of the majority of immediate and near-term improvements from the SMP. Due to limited funding available at the time, this only included replacement of the worst sections of pipeline that were identified during review of the CCTV results. Construction funding was subsequently received, and construction is now currently underway to complete the following collection system-related improvements: lining or replacement of approximately 2,700 feet of 6-inch through 12-inch pipelines; replacement of five open-cut spot repairs; eleven internal patch repairs; and rehabilitation of four manholes. Subsequent collection system improvement projects will be required in the future to address the next most-immediate system needs.

4.2.4 Equipment

BWD maintains an inventory of general equipment and emergency repair parts. Specialty equipment, emergency repair parts, and contracted repair services can typically be obtained from local area vendors within a 24-hour period.

4.2.5 Training

BWD trains employees on all equipment used in the sanitary sewer system according to manufacturers' recommendations and/or industry best practices. BWD developed an Injury and Illness Prevention Plan (IIPP) that includes associated safe working practices and required employee training. The District intends to update the IIPP and complete staff training on it. BWD uses outside trainers to maintain compliance with Cal-OSHA training requirements.

Element 5: Design and Construction Standards

This element of the SSMP discusses the design and performance provisions for the District. This section fulfills the Design and Construction Standards requirement (Element 5) of the SWRCB SSMP.

5.1 Regulatory Requirements for Design and Construction Standards

The requirements for the Design and Construction Standards Element of the SSMP are summarized below:

Installation, Rehabilitation, and Repair

The District must identify design and construction standards and specifications for the installation of new sewer systems, pump stations, and other appurtenances and for the rehabilitation and repair of existing sewer systems.

Inspection and Testing of New and Rehabilitated Facilities

The District must have procedure and standards for inspecting and testing the installation of new sewers, pumps, and other appurtenances and for rehabilitation and repair projects.

5.2 Design and Construction Standards Discussion

BWD is in the process of obtaining grant funding to formalize design and construction standards that will be used by BWD staff and communicated to consulting engineers and/or developers as needed. BWD intends to adopt current City of Redding Design and Construction Standards and modify them to include BWD specific requirements and exceptions. BWD maintains current construction standards in Section 3 of Sewer Ordinance No. 90-01. Current standards include information on the material and manner of construction of sewer service laterals. The City of Redding Construction Standards include design, construction, and testing criteria for the installation of new sewer systems and pump stations.

5.2.1 Installation, Rehabilitation, and Repair

BWD shall only approve sewer construction plans that meet the requirements of the District's criteria. The District intends to adopt City of Redding Construction Standards Sections 300.00 through 390.00, which are applicable to the wastewater system and modify them to include BWD requirements. The City of Redding Construction Standards include standard plans and specifications for the construction of sanitary sewers and appurtenances to ensure that sewer lines and connections are properly designed and constructed. The current version of the City of Redding published standards is included for reference in Appendix C. The construction standards are periodically updated as changes develop, which can be found on the City of Redding website.

5.2.2 Inspection and Testing of New and Rehabilitated Facilities

The process for testing and inspecting of new rehabilitated or repaired facilities is available within the City of Redding Construction Standards Sections 300.00, 300.10, and 300.50 that BWD intends to adopt. As written into the standards, all testing equipment and labor shall be provided by the contractor. Inspection shall be performed by BWD or its contracted engineer to ensure compliance has been achieved.

Element 6: Sanitary Sewer Overflow Emergency Response Plan

This section of the SSMP provides a summary of the District's Sanitary Sewer Overflow Emergency Response Plan (SSOERP). The complete plan is attached in Appendix B. This section fulfills the Overflow Emergency Response Plan requirement (Element 6) of the SWRCB SSMP requirements.

6.1 Regulatory Requirements for Overflow Emergency Response Plan

The summarized requirements for the SSOERP Element of the SSMP are as follows:

The District shall develop and implement an overflow emergency response plan that identifies measures to protect public health and the environment. At a minimum, this plan must include the following:

- a. Proper notification procedures so that primary responders and regulatory agencies are informed of all SSOs in a timely manner.
- b. A program to ensure appropriate response to all overflows.
- c. Procedures to ensure prompt notification to appropriate regulatory agencies and other potentially affected entities (e.g., health agencies, regional water boards, water suppliers, etc.) of all SSOs that potentially affect public health or reach the waters of the state in accordance with the Monitoring and Reporting Program (MRP). All SSOs shall be reported in accordance with this MRP, the California Water Code, other state law, and other applicable Regional Water Board WDRs or National Pollution Discharge Elimination System (NPDES) permit requirements. The SSMP should identify the officials who will receive immediate notification.
- d. Procedures to ensure appropriate staff and contractor personnel are aware of and follow the SSOERP and are appropriately trained.
- e. Procedure to address emergency operations such as traffic and crowd control and other necessary response activities.

- f. A program to ensure all reasonable steps are taken to contain untreated wastewater, prevent discharge of untreated wastewater to waters of the United States, and minimize or correct any adverse impact on the environment resulting from the SSOs, including such accelerated or additional monitoring as may be necessary to determine the nature and impact of discharge.

6.2 Overflow Emergency Response Plan Discussion

The SSOERP is summarized in the sections below. The complete plan is attached in Appendix B

The SSOERP is divided into nine sections as follows:

- I. Purpose
- II. General
- III. Overflow Response Procedure
- IV. Regulatory Agency Notification Procedure
- V. Distribution and Maintenance of SSOERP
- VI. Emergency Response Procedures
- VII. Appendix A – SSO Reporting Form & Chain of Communication for Reporting SSOs
- VIII. Appendix B – SSO Volume Estimation Methods
- IX. Appendix C – Water Quality Sampling Guidelines for Spills Greater Than 50,000 Gallons

6.2.1 SSO Notification

Section 3 of the SSOERP covers spill detection, including the procedure for getting the first responder to the site of a potential SSO. The District receives phone calls at one main telephone number that is staffed during business hours. After business hours, the calling party receives a message telling them to contact the on-call operator via on-call cell phone. The District publishes the main telephone number in the local telephone book, on the District website, as well as posting it at the District office. When District staff observe an SSO during the course of their regular activities, they are instructed to call in and notify the main office and to begin responding to the situation if possible.

6.2.2 SSO Response

Section 3 of the SSOERP also covers spill response, including responsible parties, safety, and initial containment measures. During regular business hours, District office staff dispatches one or more District operators to respond to a potential SSO notification. The District goal for responding to an SSO during business hours is 15 minutes from receipt of call to arrival at the scene of the problem. During non-business hours, the reporting party contacts the on-call operator to respond to a potential SSO. The District goal for responding to an SSO during non-business hours is 60 minutes, including time for the on-call operator to arrive at the District office, retrieve response equipment, and arrive at the scene of the problem. The on-call operator becomes the SSO first responder and is responsible for mitigation, documentation, most reporting, and follow-up.

6.2.3 SSO Reporting

Section 4 and Appendix A of the SSOERP covers spill reporting, including internal BWD reporting and external state and local agency reporting.

6.2.4 SSO Impact Mitigation

Section 3 of the SSOERP covers spill mitigation and cleanup including procedures for handling a prolonged SSO situation. Section 6 of the SSOERP covers SSO response for different situations including wet weather overflows, pump station failures, and force main breaks. Mitigation efforts include instructions for setting up perimeters and control zones to contain an SSO and prevent sewage from reaching surface waters, storm drains, or other sensitive environments.

Element 7: Fats, Oils, and Grease Control Program

This section of the SSMP discusses the District's FOG control measures, including identification of problem areas, focused cleaning, and source control. This section fulfills the FOG Control Program requirement (Element 7) for the SWRCB SSMP.

7.1 Regulatory Requirements for FOG Control Program

The requirements for the FOG Control Program Element of the SSMP are summarized below:

The District shall evaluate its service area to determine whether a FOG control program is needed. If the District determines that a FOG program is not needed, the District must provide justification for why it is not needed. If FOG is found to be a problem, the District must prepare and implement a FOG source control program to reduce the amount of these substances discharged to the sanitary sewer system. The FOG source control program shall include the following as appropriate:

1. An implementation plan and schedule for a public education outreach program that promotes proper disposal of FOG.
2. A plan and schedule for the disposal of FOG generated within the sanitary sewer system service area. This may include a list of acceptable disposal facilities and/or additional facilities needed to adequately dispose of FOG generated within a sanitary sewer system area.
3. The legal authority to prohibit discharges to the system and identify measures to prevent SSOs and blockages caused by FOG.
4. Requirements to install grease removal devices (such as traps or interceptors), design standards for grease removal devices, maintenance requirements, BMP requirements, record keeping, and reporting requirements.

5. Authority to inspect grease-producing facilities, enforcement authorities, and determination of whether the District has sufficient staff to inspect and enforce the FOG ordinance.
6. An identification of sewer system sections subject to FOG blockages and establish a cleaning maintenance schedule for each section.
7. Development and implementation of source control measures for all sources of FOG discharged to the sewer system for each sewer system section identified in (6) above.

7.2 FOG Control Program Discussion

BWD has residential and commercial properties connected to the sanitary sewer system. There are a number of restaurants and community halls in town with fully functional kitchens. Only a small number have grease traps installed.

7.2.1 Public Education Outreach Program

BWD will notify sewer customers of their new FOG control program in a variety of ways. Information on proper disposal of FOG and other SSO prevention measures, including installation of grease traps, backwater valves, sewer lateral maintenance, etc. will be distributed through publication of brochures, utility bill inserts, and/or individual notices to property owners annually. These notifications provide descriptions of grease control efforts that can be undertaken by homeowners and businesses alike. These methods are usually effective in relaying information to a community on proper disposal of FOG and other SSO prevention methods. Other effective ways to communicate with the public are being considered, such as use of the door hangers, participation in community events, the District's web page, and social media.

FOG in the local sewer system can be a prime contributor to an SSO. Related health and safety issues can also result from the discharge of pharmaceuticals and pesticides into the wastewater collection system. Although not usually a causative factor in sewer overflows, these chemicals have the potential to be toxic and have disruptive environmental and

biological effects. Preventing discharges of such chemical compounds into the sewers should be part of the community education and outreach program as well.

7.2.2 Disposal of FOG

The FOG control program will inform sewer customers of proper disposal options through various public outreach efforts. If FOG is found in the public sewer system during scheduled cleaning operations or clearing of a blockage, the FOG is collected and removed from the system to a paved sludge drying bed for later hauling to the landfill. FOG in liquid form is flushed down by hydro jetting to designated treatment facilities for disposal.

7.2.3 Legal Authority

The District's Sewer Ordinance, discussed in Chapter 3 herein, provides legal authority to prohibit illegal discharges, FOG blockages, and prevent SSOs. The District intends to update this ordinance in which case section numbers may change. Refer to the most current Sewer Ordinance when reviewing BWD legal authority. Sewer Ordinance No. 90-01 Section 10.01 prohibits discharge of "any water or waste containing fats, wax, grease, or oils, whether emulsified or not, in excess of one hundred (100) mg/L or containing substances which may solidify or become viscous at temperatures below 60 degrees F," as well as other materials that cannot be discharged into the sewer system.

Section 11.03 of Sewer Ordinance No. 90-01 states: "Any person found to be in violation of any provision of this Ordinance shall be served by the District with written notice stating the nature of the violation and provided a reasonable time limit for satisfactory correction. The offender shall, within the period of time stated in such notice, permanently cease all violation. Any person who shall continue any violation beyond the limit specified in the written notice above, shall be subject to disconnection from the District's services, including but not limited to the sanitary sewers upon five (5) days' written notice, or shall be fined an amount not exceeding five hundred (\$500.00) dollars, or be imprisoned for not more than six (6) months in the county jail, or penalized by both fine and imprisonment for each violation. Each day in which any such violation shall continue shall be deemed a separate offense."

Although no industrial users currently exist in the District, any future discharges from industrial classification facilities will be controlled under the terms of an industrial wastewater discharge permit, which is issued and monitored by the District.

7.2.4 Requirements for Grease Removal Devices

The District requires all establishments that handle, prepare, cook, or serve foods or produce, or when in the opinion of the District Manager, an establishment may introduce grease into a sanitary sewer in quantities that can affect the proper functioning of the sewage works, to install grease removal devices per the requirements of Section 5 of Sewer Ordinance No. 90-01. Grease removal devices are not required for private living quarters or dwelling units. All automotive service bays and repair shops must also have floor drains connected to the sanitary sewer. All drains must have an approved grease trap or oil separator.

Best management practices (BMPs) described below will be included in public outreach materials and reviewed with major contributors of FOG to the sewer system during routine grease trap inspections and on an as-needed basis.

Bulk or Dry Cleanup

- Practice using bulk and dry materials cleanup before using methods that use water.
- Remove bulk or other solid food and grease laden substances into a suitable container before rinsing or washing the initial containers or surfaces that will drain into the plumbing system.
- Keep drain screens in place and fully serviceable to avoid clogging drains or accumulating FOG or grit on the interiors of pipes.
- Do not pour grease, fats, or oils down the drain, nor place food scraps in the drain.
- Use food grade paper to soak up oils and grease and dispose of appropriately.
- Use paper towels to wipe down surfaces and work areas. Cloth towels require washing and thereby introducing FOG back into drains.
- Success of bulk or dry cleanup is dependent upon the behavior of individuals and their access to tools and materials for use in removing bulk and dry materials before washing.

Spill Prevention

- Preventing spills reduces the amount of waste that will require cleanup.
- A dry surface work place is safer for everyone in avoiding slips, trips, and falls.
- Capture bulk or dryer materials and place them into an appropriate container.
- Do not overfill containers and avoid spills.
- Cover any FOG container before transporting to the rendering storage container.
- Provide employees with proper tools to transport materials without spilling.

Maintenance

- Whatever method(s) are being used to collect, filter, and store FOG, ensure that equipment is regularly maintained.
- Employees should be aware of and trained to perform correct and scheduled cleaning procedures.
- A daily and weekly maintenance schedule is highly recommended.
- Contract with a responsible service company to regularly and thoroughly clean larger components and spaces requiring specialized equipment and skills (e.g., large hood filters, hot tanks, floor drain pipes, specialty tools).
- Smaller and less complex elements can be cleaned by hand by the user (e.g., small hood filters, counter/bench tops, sinks, storage areas, daily tools).
- Skim/filter fryer grease daily and test the oil to determine when change is necessary. This extends the life of both the fryer and the oil. Build-up of carbon deposits on the bottom of the fryer acts as an insulator that forces the fryer to heat longer, thus causing the oil to break down sooner.
- Avoid discharging fryer oil into a drain or grease trap, but dispose into a rendering container for transport to a rendering company.
- Cleaning intervals depend upon the type of product being prepared and the typical deposition of materials experienced. The larger the volume produced and deposits incurred, the more frequent the cleaning. This may warrant setting up a system of high use, high deposition work to be done on certain equipment that is cleaned more frequently than others to confine maintenance efforts.

Grease Traps and Interceptors

- For grease traps and interceptors to be effective, the units must be properly sized, constructed, and installed in a location to provide an adequate retention time for settling and accumulation of the FOG.
- For information on properly locating, constructing, and sizing grease traps and interceptors, review Section 5.02 of Sewer Ordinance No. 90-01.
- Ensure all grease-bearing drains discharge to the grease trap/interceptor.
- No toilet or shower waste should be plumbed to the trap/interceptor.

Oil and Grease Collection/Recycling and Food Donations

- FOG consists of commodities that if handled properly can be treated as a valuable resource.
- Some rendering companies will offer services free of charge, and others will give a rebate on the materials collected. Contact local rendering representative for specific information and details.
- Use only covered rendering barrels and make sure all drain screens are installed.
- Use a three-compartment sink for dishware washing. Begin with a hot pre-wash, then a scouring detergent wash, and then a hot rinse. Each step should be trapped to capture non-emulsified FOG.
- Donations can reduce disposal costs. Ensure that edible food is not washed or flushed down the drain. Edible food waste may be donated to a local food bank. Inedible food waste can be collected by a garbage feeder that will use discards for feeding livestock.

7.2.5 Authority to Inspect

The District intends to update the current Sewer Ordinance to add the legal authority to inspect and enforce FOG compliance and ensure grease traps and interceptors are properly maintained and serviced. Sewer Ordinance No. 90-01 Section 10 contains language that prohibits the discharge of any substance that can harm the sewage works, the sewage treatment plant, and the health, safety and general welfare of the public. To complete these inspections and enforce FOG noncompliance, the District may need to hire additional staff or partner with the Fire Department to complete grease interceptor and fire code inspections simultaneously.

Inspection and public outreach to system users with grease traps, or those needing them, is a critical component of the District's source control program. Owners are required to maintain, at their expense, grease traps and interceptors in continuous and efficient operation at all times. Sewer Ordinance No. 90-01 grants the District legal authority to prohibit illegal discharges, FOG blockages, and SSOs. The District intends to update the Ordinance to include the following: specific language regarding the District's authority to inspect grease traps, and specific details as to when a grease trap is required; what to do about illegal connections, including having an amnesty clause allowing time to come into compliance; and requiring proof of maintenance upon request of those who have grease traps. The Field Superintendent will determine the source of FOG blockages, and the District Manager will work with the owner to determine the cause and appropriate remedy. Enforcement will be conducted as needed in response to the problem identified by BWD.

7.2.6 Cleaning Schedule for Identified FOG Prone Sewer Segments

The District will identify segments of the collection system as prone to FOG areas and label them as hot spots. These hot spots will be included in the preventive maintenance program. Portions of the collection system with persistent FOG problems will be inspected and cleaned more frequently, depending on the magnitude of the problem. If these areas continue to have FOG problems, BWD may implement regular use of an environmentally friendly degreasing agent as part of this program. Consideration of this or other degreasing options will primarily be based on findings of the Pipeline Cleaning and Monitoring Programs.

7.2.7 Source Control Measures

As part of the FOG control program, the District will develop and implement source control measures. Source control measures will include identifying effective maintenance for each hot spot location, public outreach, enforcement, and maintenance activities described previously in this element. These activities will be reviewed and amended as needed and as conditions change.

Element 8: Capacity Management

This section of the SSMP discusses the District's System Evaluation and Capital Improvement Program. This section fulfills the System Evaluation and Capacity Assurance Plan requirement as well as the Capacity Assessment requirement (Element 8) for the SWRCB SSMP.

8.1 Regulatory Requirement for Capacity Management

The requirement for the System Evaluation and Capacity Assurance Plan Element of the SSMP are summarized below:

- **System Evaluation and Capacity Assessment** - The District must evaluate those portions of the sanitary sewer system that are experiencing or contributing to an SSO discharge caused by hydraulic deficiency. The evaluation must provide estimates of peak flows (including flows from SSOs that escape the system) associated with conditions similar to these causing overflow events, estimates of the capacity of key system components, hydraulic deficiencies (including components of the system with limiting capacity), and major sources that contribute to the peak flows associated with overflow events. Where design criteria do not exist or are deficient, the District must establish appropriate design criteria.
- **Capacity Assurance Plan** - The district must establish a short- and long-term CIP to address identified hydraulic deficiencies including prioritization, alternatives analysis, and schedules. The CIP may include increase in pipe size, I/I reduction programs, increase and redundancy in pumping capacity, and storage facilities. The CIP shall include an implementation schedule and shall identify sources of funding. The District shall develop a schedule of completion dates for all portions of the CIP. This schedule shall be reviewed and updated at least every two years.

8.2 Capacity Management Discussion

BWD's system evaluation and capacity enhancement measures are discussed below.

8.2.1 System Evaluation and Capacity Assessment

According to the hydraulic modeling completed as part of the SMP, the collection system in general appears to have adequate capacity for existing conditions and projected flows, with a couple of exceptions. One sewer segment within the existing collection system currently shows some signs of surcharging during peak rain events in the model, although this has not been observed in the field and requires further consideration for corrective action in order to increase sewer capacity (i.e., Park Avenue sewer). Another sewer shows a potential for blockage and possible overflow due to apparent deficiencies in sewer grade and construction (i.e., Bartel Street sewer). For a full summary of collection system capacity and conditions, refer to the BWD SMP.

As part of future growth, analysis will need to be done to determine the need to increase capacity of the infrastructure to maintain compliance with this SSMP and all other state regulations. Projected future growth for the next 60 years is discussed in the BWD SMP.

8.2.2 Capacity Assurance Plan

The need for sewer improvements has been determined using the best available information regarding existing design capacity and flow conditions. As described in the SMP, improvements have been scheduled into the four different time periods listed below:

1. **Immediate-Term (Present to 2022):** Improvements where existing capacity is clearly less than the calculated theoretical and are thus needed as soon as possible, or are needed to improve safety or performance of existing facilities (preferably completed within 5 to 10 years).
2. **Near-Term (2022 to 2032):** Other improvements that are marginal in capacity, or will be over the theoretical capacity in the next 10 to 20 years, or are needed to improve performance or efficiency.

3. Intermediate-Term (2032 to 2052): Improvements that are marginal in capacity, or will be over the theoretical capacity in the next 20 to 40 years, or are needed to improve performance or efficiency.
4. Long-Term (2052 to 2072): Remaining improvements that are theoretically needed to have adequate capacity to meet proposed 60-year development. Scheduling of these sewer facilities will likely be more definite in future Master Plan updates.

A preliminary cost estimate for the staged WWTP and general sewer collection system improvements is shown in Table 7 of the BWD SMP. Funding for these improvements will likely come from wastewater revenues in combination with grants and low-interest loans. Growth-related improvements will come from capacity charges, local improvement costs, and service connection fees as determined in the Estimates of Cost and Financial Considerations section of the BWD SMP. Refer to the SMP for details of the CIP.

As previously discussed herein, since completion of the SMP, grant funding was obtained for planning, design, and construction of a significant WWTP and collection system improvement project. Construction of most SMP immediate- and near-term recommended improvements is currently underway. Unfortunately, due to funding limitations in place at the time of funding acquisition, not all needed improvements are able to be completed. As such, subsequent grant funding applications and improvement projects to address existing system deficiencies are anticipated for years to come.

Element 9: Monitoring, Measurement, and Program Modifications

This section of the SSMP outlines the process that the District will follow to evaluate the effectiveness of the SSMP and to identify updates that may be needed for a more effective program. This section fulfills the Monitoring, Measurement, and Program Modifications requirement (Element 9) for the SWRCB SSMP.

9.1 Regulatory Requirements for Monitoring, Measurement, and Program Modifications Element

The requirement for the Monitoring, Measurement, and Program Modifications Element of the SSMP are summarized below:

The District shall:

1. Maintain relevant information that can be used to establish and prioritize appropriate SSMP activities.
2. Monitor the implementation and, where appropriate, measure the effectiveness of each element of the SSMP.
3. Assess the success of the preventive maintenance program.
4. Update the program elements, as appropriate, based on monitoring or performance evaluations.
5. Identify and illustrate SSO trends, including frequency, location, and volume.

9.2 Monitoring, Measurement, and Program Modifications Discussion

BWD maintains complaint and blockage records in a hard copy format, maintains hard copy logs of cleaning and other preventive maintenance activities, and records problems (e.g., excessive debris, observed manhole defects) identified through regular sewer maintenance activities on work order forms. The District intends to develop a formal process of electronically maintaining records of these activities.

BWD will evaluate the performance of the wastewater collection system at least annually. BWD will update the data and analysis in this section at the time of evaluation. BWD may

use other performance measures in the evaluation. BWD will prioritize the actions and initiate changes to this SSMP and the related programs based on results of the evaluation.

The indicators that BWD will use to measure the performance of the wastewater collection system and the effectiveness of the SSMP are:

1. Total number of SSOs.
2. Number of SSOs by each cause (roots, grease debris, pipe failure, capacity, pump station failures, and other).
3. Portion of sewage contained compared to total volume spilled.
4. Volume of spilled sewage discharged to surface water.
5. Planned to actual performance for preventive maintenance.

BWD will create a baseline from the above criteria as soon as the preventive maintenance program is implemented. Trends will be added when the quantity of data is adequate to determine effectiveness of the SSMP.

Element 10: SSMP Audits

This section of the SSMP outlines who will audit the SSMP and how often. This section fulfills the SSMP Audit requirement (Element 10) for the SWRCB SSMP.

10.1 Regulatory Requirements for the SSMP Audits Element

Requirements for the SSMP Audits Element of the SSMP are summarized below:

The District shall conduct periodic internal audits appropriate to the size of the system and the number of SSOs. At a minimum, these audits must occur every two years, and a report must be prepared and kept on file. This audit shall focus on evaluating the effectiveness of the SSMP and the District's compliance with the SSMP requirements, including identification of any deficiencies in the SSMP and steps to correct them.

10.2 SSMP Audit Discussion

BWD will complete audits of the SSMP every two years. Audits will be completed internally. The audits will include:

1. Review of progress made on development of SSMP elements.
2. Identification of successes of implementing SSMP elements and needed improvements.
3. Description of system improvements during previous two years.
4. Description of system improvements planned for the next two years.

Element 11: Communication Plan

This section of the SSMP outlines the process involved in communicating with interested members of the public regarding the development, implementation, and performance of this plan. This section fulfills the Communication Program requirement (Element 11) for the SWRCB SSMP.

11.1 Regulatory Requirements for the Communication Plan Element

Requirements for the Communication Plan Element of the SSMP are summarized below:

The District shall communicate on a regular basis with the public on the development, implementation, and performance of the SSMP. The communication system shall provide the public with the opportunity to provide input to the District as the program is developed and implemented. The District shall also create a plan of communication with systems that are tributary and/or satellite to the District's sanitary sewer system.

11.2 Communication Plan Discussion

BWD will report the performance of the SSMP and results of the internal audit to the Board of Directors every two years at regularly scheduled meetings. The performance information will be included in the minutes of that public meeting. Performance information will include the performance indicators listed in the SSMP under Element 9: Monitoring, Measurement, and Program Modifications.

BWD reports SSOs electronically to the California Integrated Water Quality System (CIWQS). The electronic SSO data, as well as information regarding regulatory actions, is available at: <http://www.waterboards.ca.gov/ciwqs/publicreports.html>. BWD will direct interested parties to the CIWQS public access website. The District will also begin to internally track SSO trends.

BWD does not use or have any satellite collection systems at this time. In the event that a change occurs, an agreement with the added satellite collection system would be completed and kept on file with the District Office in compliance with all requirements set forth in the SSMP.

APPENDIX A

NAMES AND CONTACT INFORMATION OF CURRENT STAFF

Contact	Position	Office Phone Number	Work Cell Phone
David Zevely	District Manager	530-335-3582	530-238-7833
Mike Skelly	Field Superintendent	530-335-3582	530-524-4395
Willie Lyons	Utility Worker	530-335-3582	530-524-4395
Keith Moore	Utility Worker	530-335-3582	530-524-4395
District Office	Administration / After Hours	530-335-3582	530-335-3582

APPENDIX B

SANITARY SEWER OVERFLOW EMERGENCY RESPONSE PLAN

APPENDIX C

CITY OF REDDING STANDARD SPECIFICATIONS AND DETAILS FOR DESIGN AND CONSTRUCTION OF WASTEWATER COLLECTION FACILITIES

1. ACCEPTABLE PIPE MATERIALS:

WASTEWATER MAINS (8"-60"),

PVC SOLID WALL SDR 26 PER ASTM D-3034
 HDPE, HIGH DENSITY POLYETHYLENE (DR17 MINIMUM)
 FUSIBLE PVC SOLID WALL PIPE (SCHEDULE 80, DR25 MINIMUM)
 PVC SOLID WALL PIPE (C900)
 VCP, VITRIFIED CLAY PIPE (EXTRA STRENGTH) - ONLY 18" AND LARGER
 (WHEN APPROVED BY CITY ENGINEER)

WASTEWATER CONNECTIONS/
 LATERALS (4" OR 6"):

ABS SOLID WALL PIPE SDR 23.5 ASTM D-2751
 ABS SOLID WALL PIPE SDR 26 ASTM D-2751
 ABS SOLID WALL PIPE (DWV SCHEDULE 40)
 PVC SOLID WALL PIPE SDR 23.5 ASTM D-3034
 PVC SOLID WALL PIPE SDR 26 ASTM D-3034
 FUSIBLE PVC SOLID WALL PIPE (SCHEDULE 80, DR25 MINIMUM)
 HDPE DR26 MINIMUM

2. THE CITY OF REDDING MAY REQUIRE THE USE OF FUSED (PVC OR HDPE) PIPE IN AREAS OF HIGH GROUNDWATER, SHALLOW COVER OR UNSTABLE GROUND CONDITIONS.
3. THE LARGEST PIPELINE THAT CAN BE TAPPED FOR A SEWER CONNECTION LATERAL IS 15 INCH UNLESS APPROVED BY THE CITY ENGINEER.
4. PRIOR TO ACCEPTANCE OF THE SEWER, THE PIPELINES SHALL BE PROPERLY CLEANED OF ALL DEBRIS, AIR PRESSURE TESTED PER STANDARD SPECIFICATIONS SECTION 306-7.8.2.4, AND MANDRELLED (WHEN APPLICABLE) BY THE CONTRACTOR; AND THEN TELEVIEWED. PROPER CLEANING TECHNIQUES AND DEVICES SHALL BE UTILIZED TO ENSURE NO DEBRIS, SAND, GRAVEL OR SILT WILL ENTER THE EXISTING CITY SEWER SYSTEM.
5. THE DOWNSTREAM END OF ALL NEW PIPELINES WHICH ARE NOT ACTIVE IN SERVICE SHALL BE PLUGGED UNTIL THE SEWER IS ACCEPTED BY THE CITY.
6. MANDREL TESTING SHALL BE REQUIRED FOR ALL PLASTIC PIPE PER STANDARD SPECIFICATIONS SECTION 306-7.8.3.
7. PRIOR TO ACCEPTANCE, ALL MANHOLES CONSTRUCTED OR REHABILITATED SHALL SUCCESSFULLY PASS A VACUUM TEST PER CITY OF REDDING CONSTRUCTION STANDARD PAGE 300.10.
8. MINIMUM DEPTH OF COVER:
 - A. 5.0 FEET OVER SEWER MAIN
 - B. 4.5 FEET OVER SEWER CONNECTIONS/LATERALS AT PROPERTY LINE (PER PAGE 301.00 & 622.00)
9. THE MINIMUM RADIUS CURVATURE FOR SEWER MAINS SHALL BE 1.5 TIMES THE MANUFACTURER'S RECOMMENDATION. ALL CURVATURE OF FLEXIBLE PIPE SHALL BE MADE BY BENDING THE PIPE. NO DEFLECTION OF THE PIPE JOINTS SHALL BE ALLOWED. SHARPER CURVES MAY BE OBTAINED BY USING 3" COUPLINGS (18" MINIMUM BETWEEN COUPLINGS).
10. SEWER TAPS ON LIVE SEWER MAINS SHALL BE PERFORMED BY THE CITY. CONTACT THE CITY PUBLIC WORKS INSPECTION TO SCHEDULE THE TAP. PHONE: 225-4170.
11. WATER STOPS SHALL BE M&H, FERNCO, OR EQUAL, IN ACCORDANCE WITH THE STANDARD SPECIFICATIONS.
12. NON-METALLIC PIPE SHALL HAVE LOCATING WIRE AND WARNING TAPE PER PAGE 608.00.
13. ALL HDPE, PVC AND FPVC PIPE INTERIOR SHALL BE LIGHT GREEN OR GRAY IN COLOR.
14. PIPE SHALL MARKED "SEWER" ON THE EXTERIOR OR HAVE A GREEN STRIPE COEXTRUDED INTO THE PIPE MATERIAL.

P:\STANDARDS\CONSTRUCTION STANDARDS\DWG\300\30000.DWG, 300.00 PDF, 9/22/2022 9:43:56 AM, daniels, Adobe PDF

DWG DATE: 7/85		SCALE: NTS	CITY OF REDDING • PUBLIC WORKS DEPARTMENT • ENGINEERING DIVISION	
10	9/22	EDIT NOTES	APPROVED BY  9-22-22 CITY ENGINEER	SANITARY SEWER CONSTRUCTION CRITERIA
9	12/18	EDIT NOTES		
8	3/18	EDIT NOTES		
7	1/18	EDIT NOTE		
6	10/16	EDIT NOTE		
5	7/13	EDIT NOTES		
MARK	DATE	REVISION		

1. EACH MANHOLE SHALL BE VACUUM TESTED IN THE PRESENCE OF THE CITY INSPECTOR FOR ACCEPTANCE PRIOR TO FINAL PAVING AND AFTER ALL BACKFILLING AND COMPACTION IS COMPLETED. INDUSTRY STANDARDS RECOMMEND THAT THE MANHOLES BE PRE-TESTED IMMEDIATELY AFTER ASSEMBLY AND PRIOR TO BACKFILLING. SUCH PRE-TESTING IS FOR THE CONTRACTOR'S CONVENIENCE AND NEED NOT BE IN THE PRESENCE OF THE INSPECTOR.
2. ALL TESTING EQUIPMENT AND LABOR SHALL BE PROVIDED BY THE CONTRACTOR.
3. ALL PIPES ENTERING THE MANHOLE SHALL BE PLUGGED, TAKING CARE TO SECURELY BRACE THE PLUGS FROM BEING DRAWN INTO THE MANHOLE.
4. THE TEST HEAD SHALL BE PLACED AT THE INSIDE OF THE TOP OF THE CONE SECTION AND THE SEAL INFLATED IN ACCORDANCE WITH THE MANUFACTURER'S RECOMMENDATION.
5. A VACUUM OF 10 INCHES OF MERCURY SHALL BE DRAWN AND THE VACUUM PUMP SHUT OFF. WITH THE VALVES CLOSED, THE TIME SHALL BE MEASURED FOR THE VACUUM TO DROP TO NINE INCHES. THE MANHOLE SHALL PASS IF THE TIME IS GREATER THAN 60 SECONDS FOR 48" DIAMETER MANHOLES, 75 SECONDS FOR 60" DIAMETER MANHOLES, AND 90 SECONDS FOR 72" DIAMETER MANHOLES.
6. IF THE MANHOLE FAILS THE INITIAL TEST, NECESSARY REPAIRS SHALL BE MADE WITH A NON-SHRINK GROUT OR EPOXY. RETESTING SHALL PROCEED UNTIL A SATISFACTORY TEST IS OBTAINED. NO GROUT SHALL BE PLACED IN THE HORIZONTAL JOINTS BEFORE TESTING.

P:\STANDARDS\CONSTRUCTION\STANDARDS\DWG\300\300.10.DWG, 8.5X11.PDF, 2/23/2018 2:34:11 PM, DANIELS

DWG DATE: 1/98		SCALE: NTS	CITY OF REDDING • PUBLIC WORKS DEPARTMENT • ENGINEERING DIVISION	
2	3/18	EDIT NOTE 6 UPDATE	APPROVED BY  3/19/18 CITY ENGINEER	
1	7/13			
MARK	DATE	REVISION		

1. DESIGN OF SEWER LINES SHALL BE BASED UPON AN AVERAGE DAILY FLOW OF 300 GALLONS PER HOUSEHOLD EQUIVALENT PER DAY PLUS 1,500 GALLONS PER ACRE PER DAY FOR STORM WATER AND GROUNDWATER INFILTRATION. PEAKING FACTORS APPLIED TO DRY WEATHER FLOWS SHALL BE 3.25 FOR RESIDENTIAL AND 1.70 FOR NON-RESIDENTIAL SERVICES.
2. MAINS AND COLLECTOR SEWER LINES SHALL BE DESIGNED WITH A MINIMUM MANNING COEFFICIENT OF $N=0.013$.
3. THE MINIMUM SLOPE ALLOWED FOR SEWER PIPELINES SHALL BE:

8"	$s=0.0040$
10"	$s=0.0030$
12"	$s=0.0025$

THE MAXIMUM LENGTH OF ANY DEAD END PIPELINE SHALL BE 250 FEET, OR LESS; SHALL HAVE A MINIMUM SLOPE OF $s=.0040$; AND SHALL HAVE NO MORE THAN FOUR SERVICE CONNECTIONS.

4. MINIMUM GRADES SHALL NOT BE LESS THAN THOSE REQUIRED TO PRODUCE A VELOCITY OF TWO (2.0) FEET PER SECOND WHEN THE SEWER SIZE SELECTED IS FLOWING FULL OR HALF FULL. PIPE SIZES SHALL NOT BE ARBITRARILY INCREASED IN ORDER TO TAKE ADVANTAGE OF A FLATTER GRADE.
5. THE MINIMUM SIZE SEWER MAIN SHALL BE 8-INCH.
6. MINIMUM DEPTH OF COVER:
 - A. 5.0 FEET OVER SEWER MAIN
 - B. 4.5 FEET OVER SEWER CONNECTIONS/LATERALS AT PROPERTY LINE (STANDARD PAGE 301.00)
7. MANHOLE SPACING:
 - A. MAINLINE SEWERS 8 TO 12 INCH : 500 FEET MAXIMUM
 - B. TRUNKLINE SEWERS 15 TO 30 INCH : 700 FEET MAXIMUM
 - C. INTERCEPTOR SEWERS 36 INCH AND LARGER : 800 FEET MAXIMUM
 - D. INTERCEPTOR AT ALL ANGLE POINTS IN HORIZONTAL AND VERTICAL ALIGNMENT
8. INSIDE DROP MANHOLES WILL ONLY BE PERMITTED WHEN APPROVED BY THE CITY ENGINEER PER 362.00 OUTSIDE DROP MANHOLES WILL NOT BE PERMITTED.
9. MAXIMUM DEPTH OF COVER:

SEWER MAINS SHALL NOT BE DESIGNED WITH COVER EXCEEDING 15 FEET FROM FINISH SURFACE GRADE, UNLESS SPECIAL PERMISSION IS RECEIVED FROM THE CITY ENGINEER.
10. NO PRIVATE FORCE MAINS WILL BE ALLOWED IN THE CITY RIGHT-OF-WAY UNLESS PERMISSION IS RECEIVED FROM THE CITY ENGINEER.
11. HORIZONTAL AND VERTICAL CURVATURE SHALL BE ONE-HALF OF THE MAXIMUM DEFLECTION RECOMMENDED BY THE MANUFACTURER.

DWG DATE: 7/85		SCALE: NTS	CITY OF REDDING • PUBLIC WORKS DEPARTMENT • ENGINEERING DIVISION	
6	3/18	EDIT NOTE 8	APPROVED BY  3/19/18 CITY ENGINEER	
5	7/13	EDIT NOTES		
4	4/06	EDIT NOTES		
MARK	DATE	REVISION	SANITARY SEWER DESIGN CRITERIA	

1. PVC SEWER PIPE AND FITTINGS FOR GRAVITY SEWERS SHALL BE MADE FROM ALL NEW, RIGID, UNPLASTICIZED POLYVINYL CHLORIDE IN ACCORDANCE WITH ASTM STANDARD SPECIFICATION D 3034 WITH A WALL THICKNESS OF AT LEAST SDR 26. SDR VALUES AND PVC MATERIAL REQUIREMENTS SHALL BE PER SECTION 207-17 OF THE STANDARD SPECIFICATIONS FOR PUBLIC WORKS CONSTRUCTION (GREENBOOK). JOINTS SHALL CONSIST OF AN INTEGRAL BELL AND RUBBER RING ELASTOMERIC SEAL (GASKETS) MEETING THE REQUIREMENTS OF ASTM D 3212 AND ASTM F 477. THE PIPE AND FITTINGS SHALL BE ASSEMBLED WITH THE PIPE MANUFACTURER'S RECOMMENDED LUBRICANT.
2. ALL PIPE SHALL HAVE A "HOME" MARK TO INDICATE FULL PENETRATION OF THE SPIGOT WHEN THE JOINT IS MADE.
3. SPECIFIC APPROVAL IS REQUIRED FOR USE OF SEWER PIPELINES FOR WHICH COMMERCIAL OR INDUSTRIAL AREAS ARE TRIBUTARY.
4. ALL PVC PIPELINES ENTERING OR LEAVING A CONCRETE STRUCTURE SHALL HAVE A FERNCO, PRESS-SEAL, OR EQUAL, WATER STOP FIRMLY CLAMPED AROUND THE PIPE EXTERIOR AND CAST INTO THE STRUCTURE BASE OR NEAR THE STRUCTURE WALL CENTER AS A WATER STOP.
5. INSTALLATION, BEDDING, AND BACKFILL REQUIREMENTS FOR PVC SEWER PIPE SHALL BE IN ACCORDANCE WITH ASTM D 2321 AS MODIFIED BY CITY OF REDDING STANDARD PAGE 610.00.
6. PRIOR TO ACCEPTANCE OF THE SEWER, THE PIPELINES SHALL BE AIR PRESSURE TESTED PER STANDARD SPECIFICATIONS SECTION 306-7.8.2.4
7. AFTER PIPE INSTALLATION AND PLACEMENT AND COMPACTION OF BACKFILL, BUT PRIOR TO PLACEMENT OF PAVEMENT, ALL PIPELINES SHALL BE CLEANED AND THEN SEPARATELY MANDRELLED TO MEASURE FOR OBSTRUCTIONS. OBSTRUCTIONS SHALL INCLUDE, BUT NOT BE LIMITED TO DEFLECTIONS, JOINT OFFSETS, AND SEWER CONNECTIONS/LATERAL PIPE INTRUSIONS. A CONTRACTOR-SUPPLIED RIGID MANDREL MEETING THE REQUIREMENTS OF THE GREENBOOK SECTION 306-7.8.3 WITH AN EFFECTIVE CIRCULAR CROSS-SECTION HAVING A DIAMETER OF AT LEAST 95 PERCENT OF THE MAXIMUM AVERAGE INSIDE DIAMETER, PER ASTM 3034, SHALL BE PULLED THROUGH THE PIPE BY HAND NOT SOONER THAN 30 DAYS AFTER COMPLETION OF PLACEMENT AND DENSIFICATION OF BACKFILL. THE MINIMUM EFFECTIVE LENGTH OF THE MANDREL SHALL BE EQUAL TO ITS NOMINAL DIAMETER. OBSTRUCTIONS DUE TO DEFLECTION SHALL BE CORRECTED BY REPLACEMENT OF THE OVER-DEFLECTED PIPE; RE-ROUNDING IN PLACE WILL NOT BE ALLOWED.
8. IF A SECTION OF PIPELINE FAILS TO MEET THE MANDREL TEST AND IS REPAIRED AND FAILS A SECOND TIME, IT SHALL BE REPLACED WITH AN APPROVED RIGID OR SEMI-RIGID PIPE MATERIAL AND CONNECTED WITH FLEXIBLE RUBBER COUPLINGS WITH STAINLESS STEEL CLAMPS.
9. PVC PLASTIC SEWER PIPELINE MAY BE MANDREL TESTED AGAIN BEFORE THE TWELFTH MONTH FOLLOWING ACCEPTANCE AT THE DISCRETION OF THE MUNICIPAL UTILITIES DEPARTMENT. THE CONTRACTOR SHALL REPAIR ANY OBSTRUCTIONS CAUSED BY EXCESS DEFLECTION.
10. ALL MANDREL TESTING SHALL BE WITNESSED BY THE CITY INSPECTOR AND BE CONDUCTED BY THE CONTRACTOR'S FORCES AND AT THE CONTRACTOR'S EXPENSE.

P:\STANDARDS\CONSTRUCTION STANDARDS\DWG\300\30050.DWG, 8.5X11.PDF, 9/22/2022 9:52:06 AM, daniels, Adobe PDF

DWG DATE: 8/92		SCALE: NTS	CITY OF REDDING • PUBLIC WORKS DEPARTMENT • ENGINEERING DIVISION	
7	9/22	EDIT NOTE 6&7	APPROVED BY  9-22-22 CITY ENGINEER	
6	3/18	EDIT NOTE 3		
5	1/18	ADD NOTE 6		
4	7/13	UPDATE		
3	4/06	UPDATE		
MARK	DATE	REVISION	POLYVINYL CHLORIDE (PVC) SEWER PIPE	

FLEXIBLE
PVC SDR 26 (8 INCH-15 INCH)

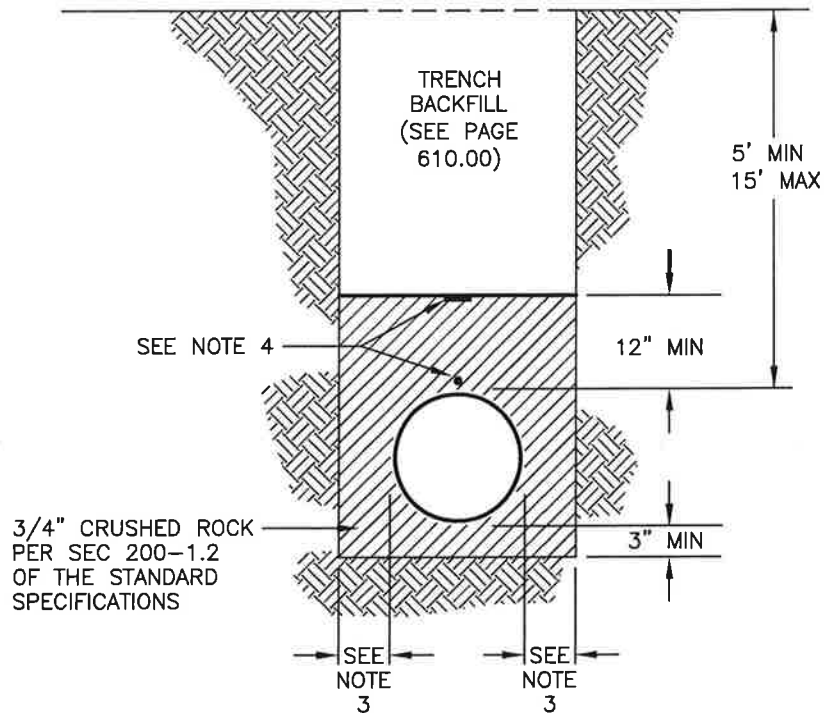

NOTES:

1. ALL PLASTIC SEWER MAINS SHALL BE AIR PRESSURE TESTED AND MANDREL TESTED WITH 5% MAX DEFLECTION PRIOR TO TELEVIEWING. THE CONTRACTOR SHALL REPAIR ANY SEWER MAIN OBSTRUCTION.
2. SEWER CONNECTIONS/LATERALS SHALL HAVE THE SAME BEDDING REQUIREMENTS AS SEWER MAINS.
3. TRENCH WIDTH ON EACH SIDE OF THE PIPE SHALL BE A MINIMUM OF EITHER FOUR (4) INCHES OR THE PIPE MANUFACTURER'S RECOMMENDED MINIMUM, WHICHEVER IS GREATER, AND A MAXIMUM OF 18 INCHES.
4. 6 NON-METALLIC PIPE SHALL HAVE LOCATING WIRE AND WARNING TAPE PER PAGE 608.00.

DWG DATE: 7/92		SCALE: NTS	CITY OF REDDING • PUBLIC WORKS DEPARTMENT • ENGINEERING DIVISION	
			APPROVED BY	BEDDING FOR PLASTIC SEWER PIPE
7	1/18	EDIT NOTE 1	 1/26/18	
6	8/16	EDIT NOTE		
5	7/13	ADD 608.00		
4	4/06	EDIT NOTES		
MARK	DATE	REVISION	CITY ENGINEER	

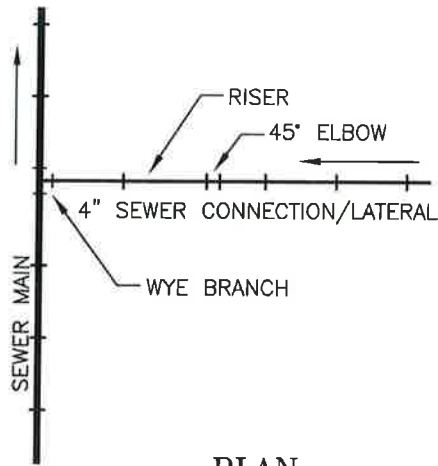

PLAN

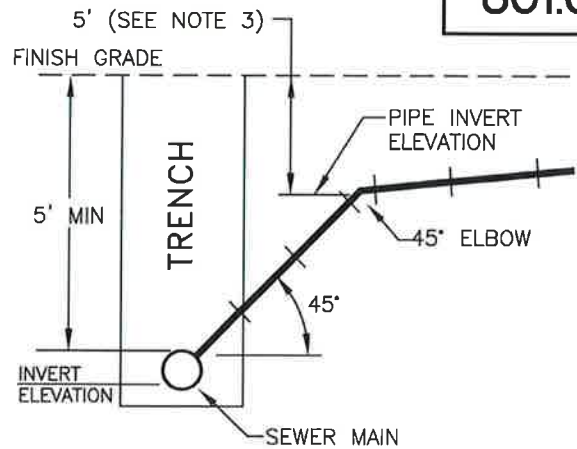

ELEVATION

TYPICAL RISER CONNECTION

(SEE NOTE 2)

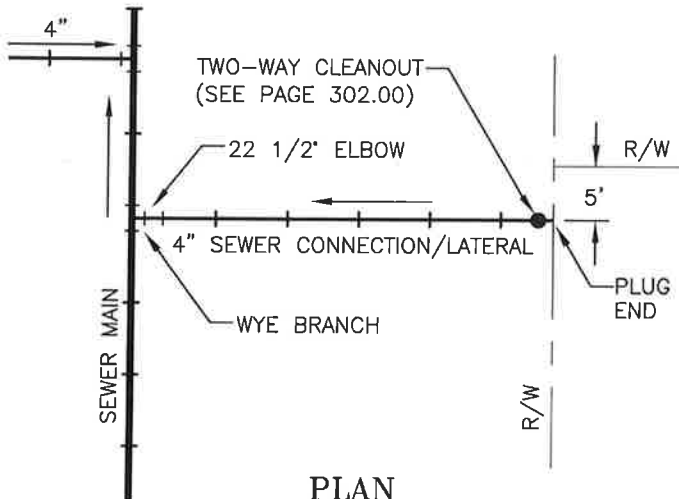

PLAN

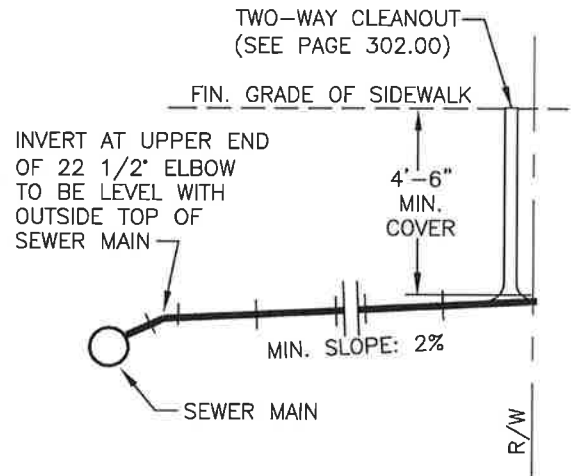

ELEVATION

TYPICAL HOUSE CONNECTION

NOTES:

1. 90° TAPS ARE ACCEPTABLE.
2. RISERS SHALL BE INSTALLED WHEN DEPTH OF SEWER MAIN EXCEEDS 6 FT.
3. VERTICAL INSTALLATIONS (STOVEPIPING) WILL NOT BE ALLOWED.
4. WHERE SEWER MAIN IS IN AN EASEMENT, INSTALL A TEE BRANCH AND PLUG.
5. PLACE 1/2" OR 5/8" PLASTIC CONDUIT (SCRAP) UPRIGHT AT PROPERTY LINE OVER END OF SEWER CONNECTION/LATERAL.
6. SEWER TAPS ON LIVE SEWER MAINS SHALL BE PERFORMED BY CITY OF REDDING CREW ONLY. CONTACT THE CITY INSPECTOR TO SCHEDULE TAP.
7. STAMP "S" INTO CURB AT LOCATION OF LATERAL.

DWG DATE: 12/91 SCALE: NTS CITY OF REDDING • PUBLIC WORKS DEPARTMENT • ENGINEERING DIVISION

MARK	DATE	REVISION
10	3/18	2 WAY CO
9	7/13	NAME CHG
8	4/06	ADD CLEANOUT

APPROVED BY

CITY ENGINEER

**TYPICAL SANITARY
SEWER LATERAL**

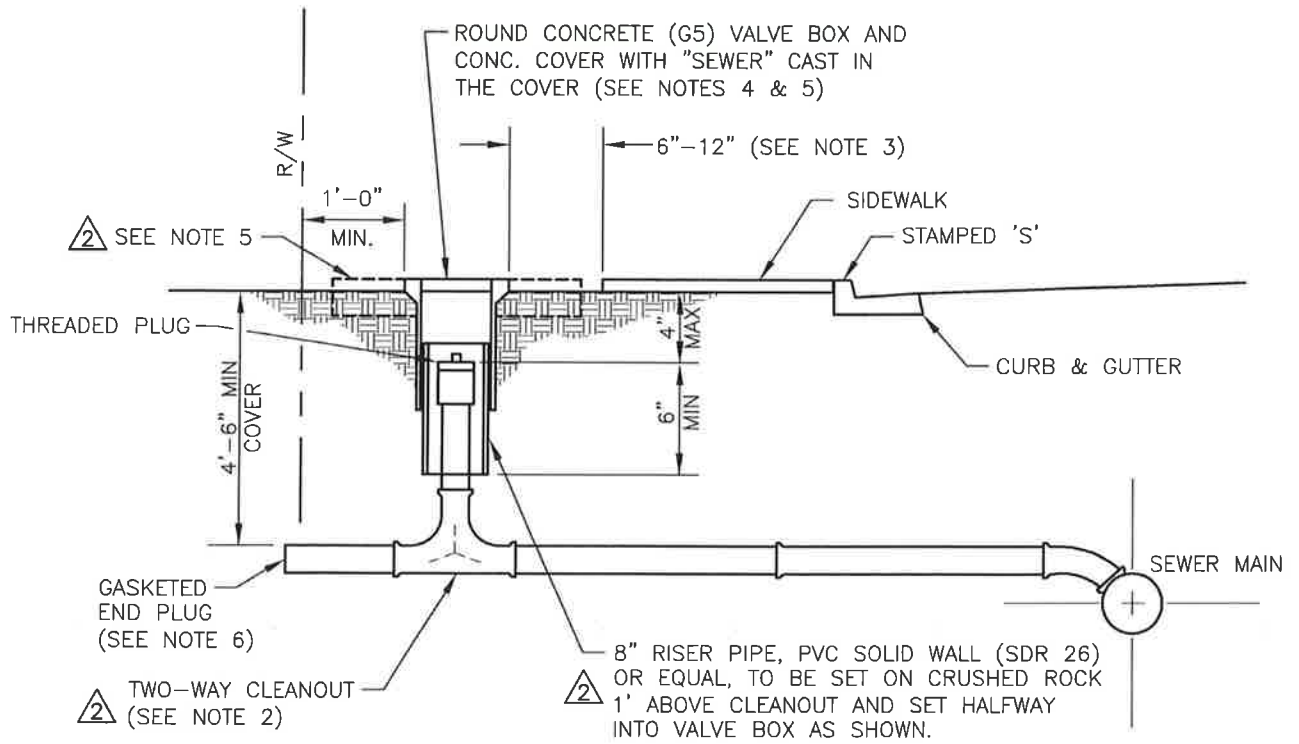

NOTES:

1. THIS STANDARD SHALL BE REQUIRED ON ALL NEW RESIDENTIAL CONSTRUCTION.
2. TWO-WAY CLEANOUT.
3. WHERE CONCRETE DRIVEWAY OR SIDEWALK SHALL EXIST, LATERAL CLEANOUT SHALL BE PLACED AT THE BACK OF CONCRETE WITH 6"-12" CLEARANCE BETWEEN CONCRETE AND CLEANOUT BOX. FOR ALL OTHER SITUATIONS, CLEANOUT SHALL BE PLACED 1' OFF THE PROPERTY LINE OR AS SHOWN ON THE PLANS APPROVED BY THE CITY ENGINEER.
4. WHERE LATERAL CLEANOUT IS LOCATED IN DRIVEWAYS OR OTHER AREAS SUBJECT TO VEHICULAR TRAFFIC, SET CLEANOUT BOX (G5) FLUSH TO FINISH GRADE, AND USE A CI TRAFFIC RATED COVER.
5. WHERE CLEANOUT IS SUBJECT TO VEHICULAR TRAFFIC AND NOT SET IN CONCRETE DRIVEWAY, POUR A 28" DIA. X 12" THICK CONCRETE COLLAR AROUND VALVE BOX.
6. ONCE THE NEW SEWER MAIN AND LATERALS HAVE BEEN TESTED, ACCEPTED, AND APPROVED TO BE PUT ON-LINE, CONTRACTOR SHALL CONNECT THE BUILDING LATERAL TO THE NEW CLEANOUT.

DWG DATE: 4/06		SCALE: NTS	CITY OF REDDING • PUBLIC WORKS DEPARTMENT • ENGINEERING DIVISION	
2	3/18	REVISE NOTES & CLEANOUT	APPROVED BY  3/19/14 CITY ENGINEER	<h2>LATERAL CLEANOUT</h2>
1	7/13	REVISE STD		
MARK	DATE	REVISION		

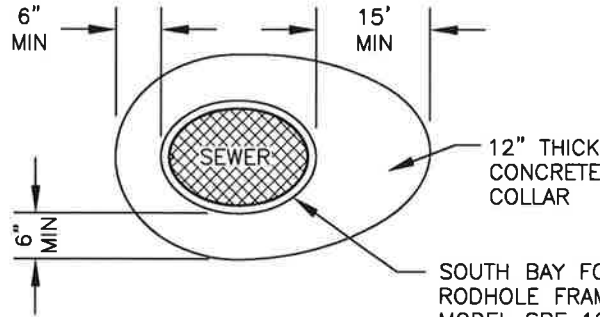

PLAN

SOUTH BAY FOUNDRY
ROD HOLE FRAME ASSEMBLY,
MODEL SBF 1249, OR
APPROVED EQUAL

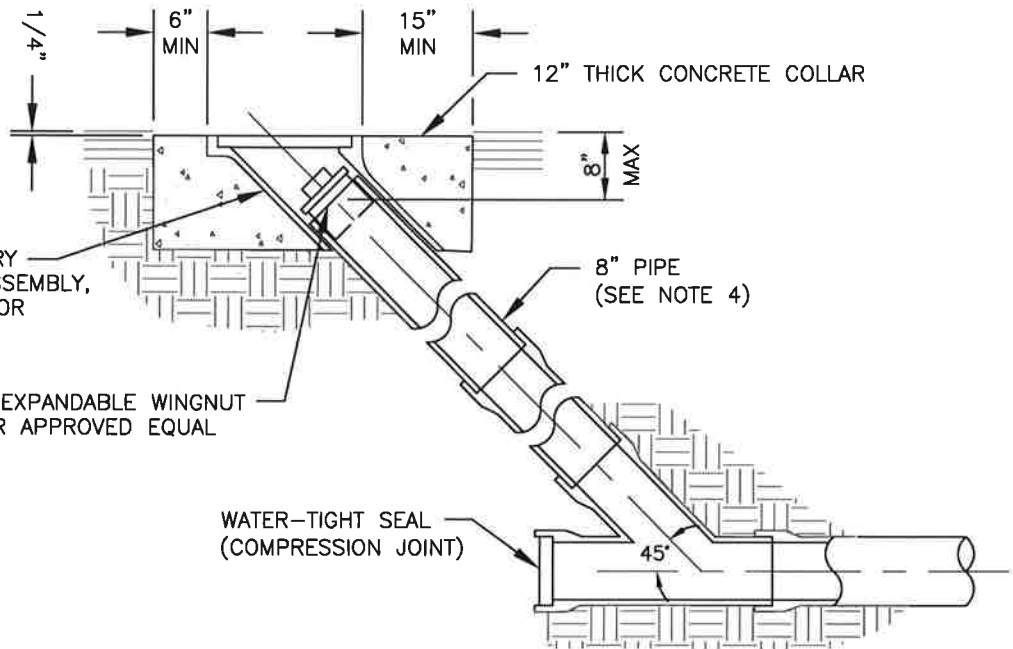

SECTION

NOTES:

1. ALL WORK SHALL CONFORM TO THE CITY OF REDDING CONSTRUCTION STANDARDS AND STANDARD SPECIFICATIONS FOR PUBLIC WORKS CONSTRUCTION (GREENBOOK).
2. ALL INSTALLATIONS SHALL BE 8" UNLESS APPROVED OTHERWISE BY THE CITY ENGINEER.
3. 1/8th BEND MAY BE USED IN PLACE OF WYE WITH APPROVAL OF THE CITY ENGINEER.
4. CONCRETE COLLAR AROUND RODHOLE FRAME SHALL BE OVAL TO MATCH FRAME ASSEMBLY.

DWG DATE: 7/11		SCALE: NTS	CITY OF REDDING • PUBLIC WORKS DEPARTMENT • ENGINEERING DIVISION	
MARK	4	7/13	APPROVED BY <i>[Signature]</i> 10/9/13 CITY ENGINEER	SEWER MAIN TERMINATION
	3	2/03		
	DATE	REVISION		

STD. MANHOLE FRAME AND COVER (PAGE 364.20 OR PAGE 364.30). FINISH GRADE ADJUSTMENT (PAGE 612.00).

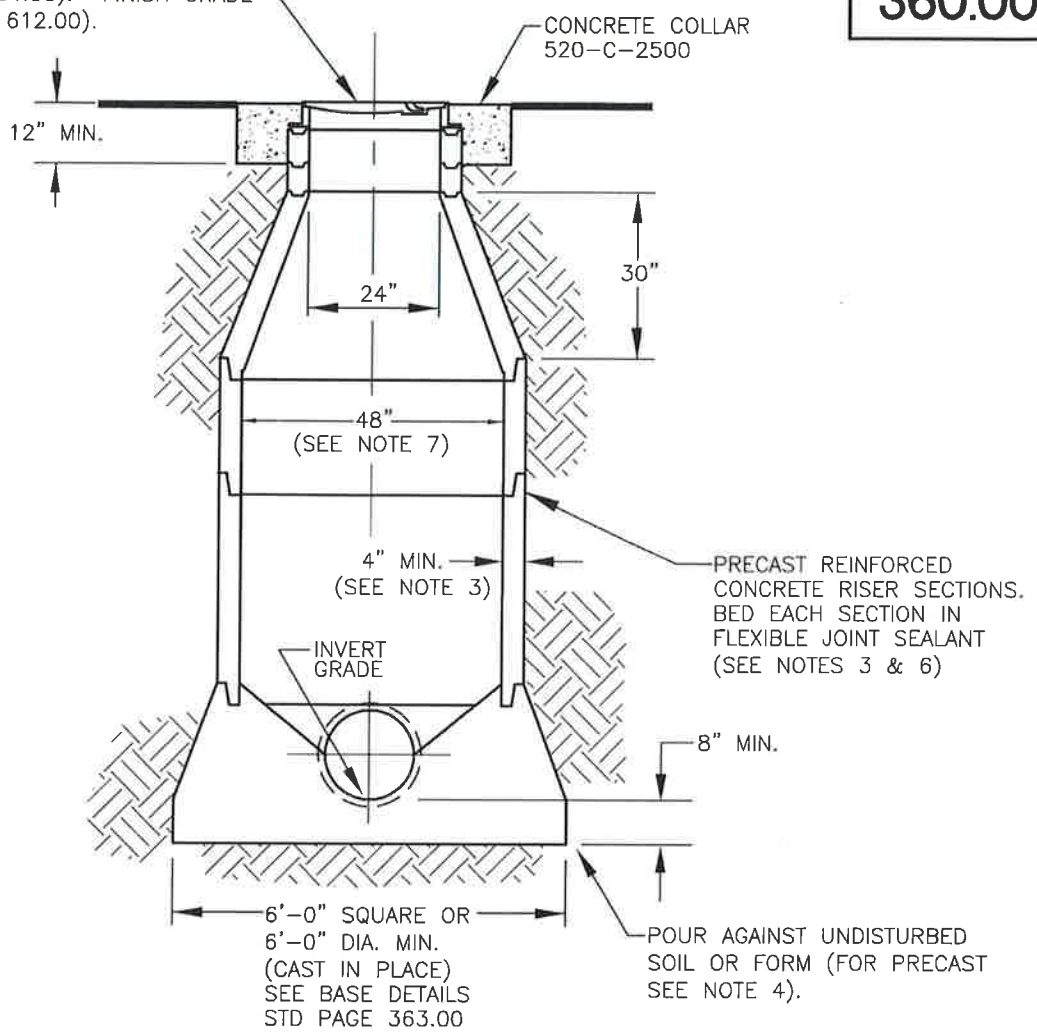

NOTES:

1. WHERE MANHOLES ARE NOT LOCATED IN STREETS OR TRAVELED WAY PLACE TOP OF MANHOLE 12" TO 24" ABOVE EXISTING GROUND PER PAGE 365.00 UNLESS OTHERWISE SHOWN ON PLANS.
2. ALL CONCRETE USED IN MANHOLE SHALL BE PER PAGE 100.00.
3. PRECAST REINFORCED CONCRETE MANHOLE SEGMENTS SHALL CONFORM TO ASTM DESIGNATION: C478-70 (4" MIN. WALL THICKNESS). ALL SECTIONS SHALL HAVE TONGUE AND GROOVE JOINTS.
4. PRECAST CONCRETE BASES MANUFACTURED BY COOK CONC. PRODUCTS, TEICHERT AGGREGATE, OR EQUAL MAY BE USED IN LIEU OF POURED IN-PLACE BASES (SEE PAGE 363.00).
5. ECCENTRIC TYPE CONCRETE CONE SECTIONS SHALL BE INSTALLED IN PLACE OF CONCENTRIC CONES WHEN DIRECTED BY THE ENGINEER. WHEN ECCENTRIC CONE SECTION IS INSTALLED, THE VERTICAL WALL SHALL BE INSTALLED DOWNSTREAM.
6. ALL SEGMENTS SHALL BE BEDDED IN FLEXIBLE JOINT SEALANT:
 - A DOUBLE BEAD SHALL BE USED IF SEALANT IS 3/4-INCH OR 1-INCH DIAMETER.
 - A SINGLE BEAD SHALL BE USED IF THE SEALANT IS 1 1/4-INCH OR GREATER DIAMETER.
7. 6'-0" MANHOLES ARE TO BE CONSTRUCTED AT THOSE LOCATIONS WHERE PIPE SIZE IS 30" OR LARGER IN DIAMETER.
8. WHEN CLAY PIPE IS INSTALLED, THE PIPE SECTION SHALL NOT EXTEND MORE THAN 12" FROM SIDE OF MANHOLE.
9. WHEN ABS OR PVC PIPE IS USED, THE BARREL OF THE PIPE SHALL BE PRE-PRIMED WITH SOLVENT AND SPRINKLED WITH SAND IN ORDER TO PROVIDE A WATERTIGHT SEAL BETWEEN THE PIPE AND CONCRETE. THIS REQUIREMENT IS IN ADDITION TO THE USE OF THE WATERSTOP.
10. PIPE MAY BE LAID THROUGH A LINE MANHOLE EXCEPT WHEN A GRADE OR LINE CHANGE OCCURS. MINIMUM DROP THROUGH ALL OTHER MANHOLES SHALL BE THE DIFFERENCE IN DIAMETERS OF THE UPSTREAM AND DOWNSTREAM PIPES OR 0.20 FT., WHICH EVER IS GREATER.
11. BACKFILL SHALL BE CLASS 'A' IN STREET R/W AND CLASS 'B' IN ALL OTHER LOCATIONS. COMPACTION PER PAGE 610.00 & PAGE 705.00.

DWG DATE: 1/98		SCALE: NTS	CITY OF REDDING • PUBLIC WORKS DEPARTMENT • ENGINEERING DIVISION	
12	3/18	12" COLLAR	APPROVED BY  3/20/18 CITY ENGINEER	TYPE 1 4 FT. SEWER MANHOLE
11	1/18	EDIT NOTE		
10	8/16	EDIT NOTE		
9	7/13	REVISE NOTES		
8	4/06	ADD NOTE		
7	2/03	NAME CHG		
MARK	DATE	REVISION		

P:\STANDARDS\CONSTRUCTION STANDARDS\DWG\360.00.DWG, 36000PDF, 3/20/2018 7:32:42 AM, DANIELS

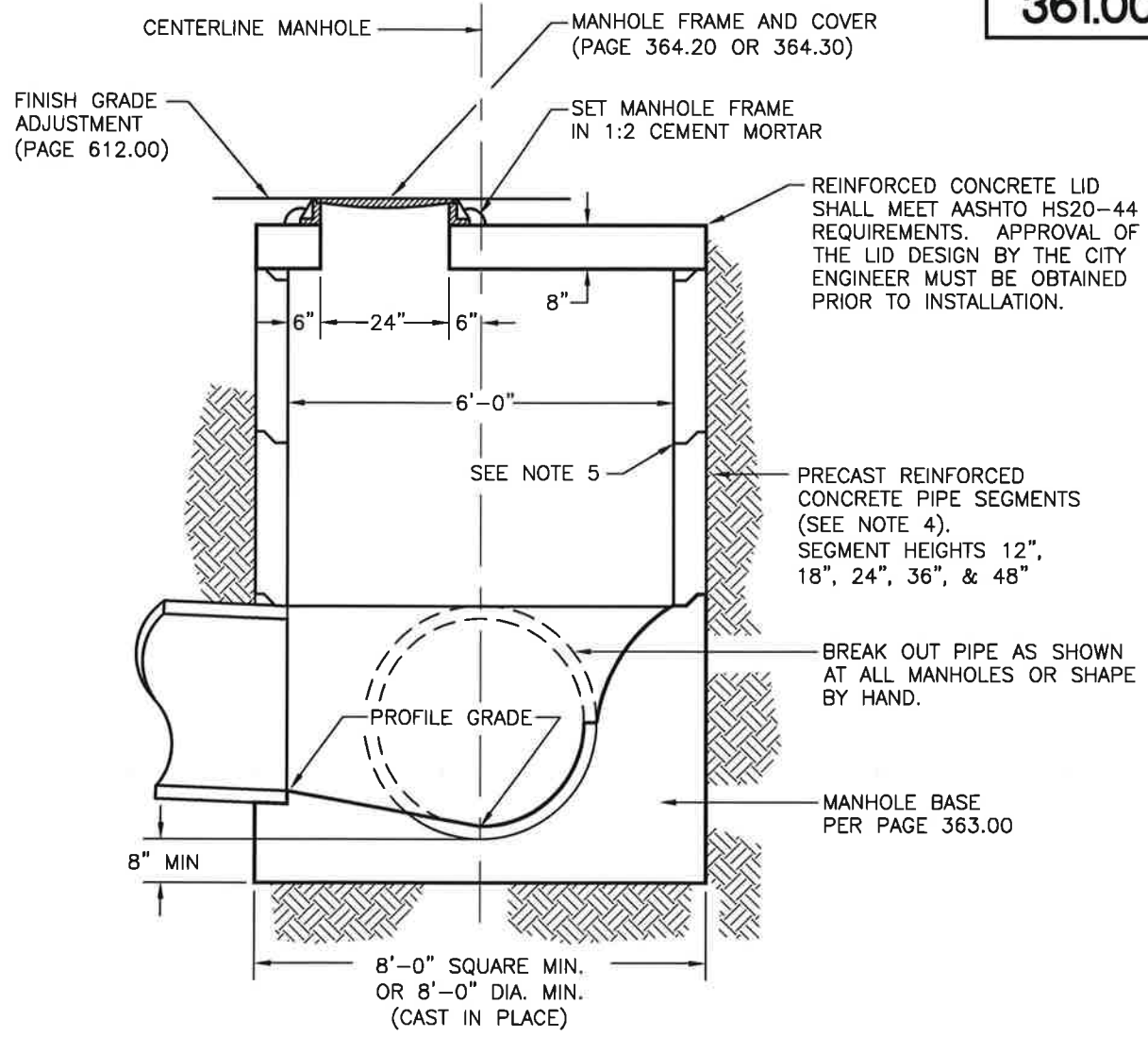

NOTES:

1. WHERE MANHOLES ARE NOT LOCATED IN STREETS, PLACE TOP OF MANHOLE COVER 12" TO 24" ABOVE FINISHED GRADE UNLESS OTHERWISE SHOWN ON PLANS.
2. ALL CONCRETE USED IN MANHOLE BASE SHALL BE PER PAGE 100.00.
3. PIPE MAY BE LAID THROUGH A "LINE" MANHOLE EXCEPT WHERE A GRADE CHANGE OCCURS. MINIMUM DROP THROUGH ALL OTHER MANHOLES SHALL BE THE DIFFERENCE IN THE UPSTREAM PIPES AND DOWNSTREAM PIPE OR 0.17 FT. WHICHEVER IS GREATER.
4. PRECAST REINFORCED CONCRETE MANHOLE SECTIONS SHALL CONFORM TO ASTM DESIGNATION C478 (6" MIN. WALL THICKNESS). ALL SECTIONS SHALL HAVE TONGUE AND GROOVE JOINTS.
5. ALL MANHOLE SEGMENTS SHALL BE BEDDED IN FLEXIBLE JOINT SEALANT (KENT-SEAL OR EQUAL).
 - A DOUBLE BEAD SHALL BE USED IF SEALANT IS 3/4-INCH OR 1-INCH IN DIAMETER.
 - A SINGLE BEAD IF SEALANT IS 1 1/4-INCH OR GREATER IN DIAMETER.
6. 6'-0" MANHOLES ARE TO BE CONSTRUCTED AT THOSE LOCATIONS WHERE PIPE SIZE IS 30" OR LARGER IN DIAMETER.
7. BACKFILL SHALL BE CLASS 'A' IN STREET R/W AND CLASS 'B' IN ALL OTHER LOCATIONS. COMPACTION REQUIREMENTS PER PAGE 610.00 & PAGE 601.00.



P:\STANDARDS\CONSTRUCTION STANDARDS\DWG\3001361.00.DWG, 361.00 PDF, 6/13/2022 10:36:47 AM, daniels, Adobe PDF

DWG DATE: 4/91		SCALE: NTS	CITY OF REDDING • PUBLIC WORKS DEPARTMENT • ENGINEERING DIVISION	
MARK	5	5/22	EDIT NOTE	APPROVED BY  6-13-22 CITY ENGINEER
	4	7/13	UPDATE	
3	2/03	EDIT NOTES		
DATE	REVISION			
STANDARD 6 FT. SEWER MANHOLE				

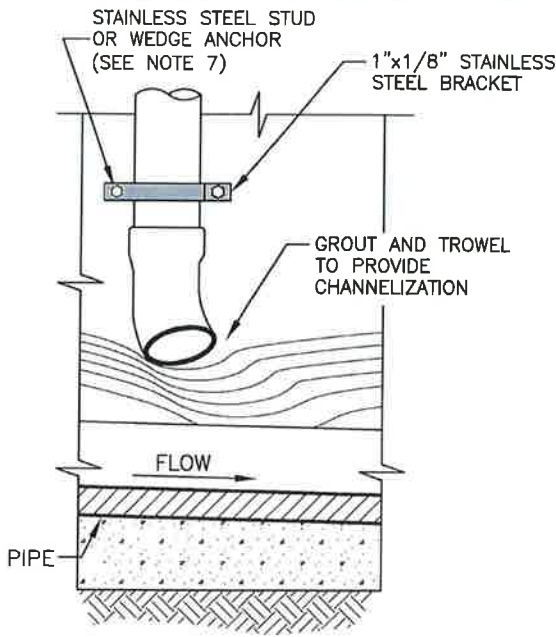

SECTION D-D

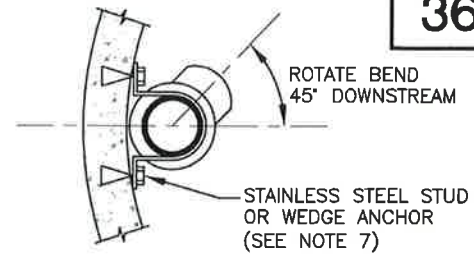

SECTION C-C

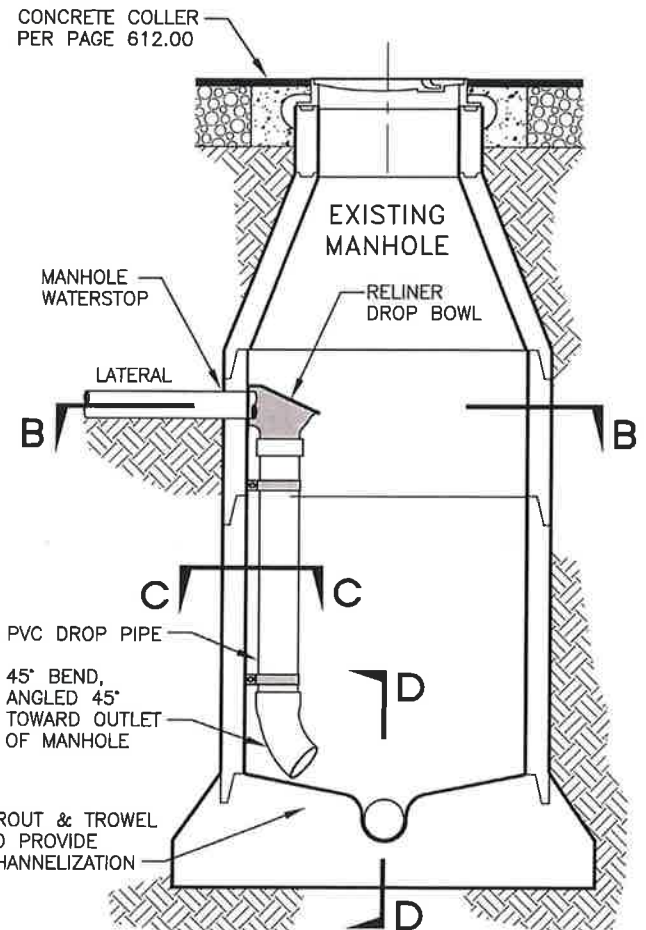

SECTION A-A

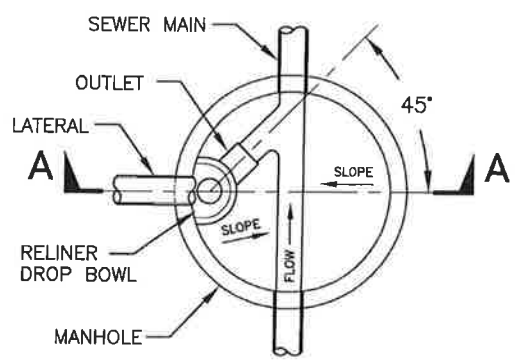

SECTION B-B

- NOTES:**
1. INSIDE DROP MANHOLES ALLOWED WHEN THE GRADE DIFFERENCE IS 6 FT. OR MORE ON EXISTING FACILITIES AND WITH SPECIAL APPROVAL BY THE CITY ENGINEER.
 2. THIS TYPE OF DROP MANHOLE CONSTRUCTION MAY BE UTILIZED ONLY WHEN 8 INCH OR SMALLER PIPE IS USED.
 3. VERTICAL PIPE SHALL BE 6 INCH FOR BOTH 6 INCH AND 8 INCH INCOMING LINES. VERTICAL PIPE MAY BE 4 INCH WHEN INCOMING LINE IS 4 INCH.
 4. ABS SCH 40 DWV PIPE SHALL BE USED IN THE DROP SECTION OF THE MANHOLE.
 5. 1"x1/8" STAINLESS STEEL BRACKETS SHALL BE USED TO SECURE VERTICAL PIPES WITHIN THE MANHOLE, WITH A MINIMUM OF ONE BRACKET PER JOINT OF PIPE AND A MINIMUM OF TWO BRACKETS PER MANHOLE INSTALLATION.
 6. BACKFILL SHALL BE CLASS 'A' IN STREET R/W AND CLASS 'B' IN ALL OTHER LOCATIONS. COMPACTION REQUIREMENTS PER PAGE 610.00 & PAGE 705.00.
 7. ALL HOLES DRILLED INTO CONCRETE FOR MOUNTING BRACKETS SHALL BE SEALED WITH WATER TIGHT EPOXY.

DWG DATE: 12/91		SCALE: NTS	CITY OF REDDING • PUBLIC WORKS DEPARTMENT • ENGINEERING DIVISION	
9	3/18	ADD COLLAR	APPROVED BY  3/19/18 CITY ENGINEER	
8	1/18	UPDATE		
7	7/13	UPDATE		
6	4/06	EDIT NOTES		
5	2/03	NAME CHG		
MARK	DATE	REVISION	4 FT. INSIDE DROP MANHOLE EXISTING MANHOLE ONLY	

P:\STANDARDS\CONSTRUCTION STANDARDS\DWG\300136200.DWG, 8.5X11.PDF, 2/26/2018 9:06:21 AM, DANIELS

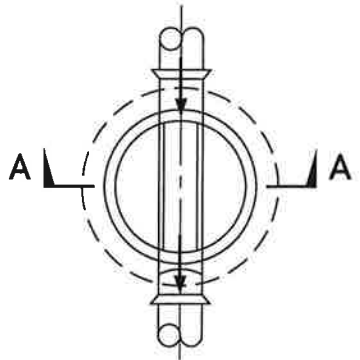

PLAN A

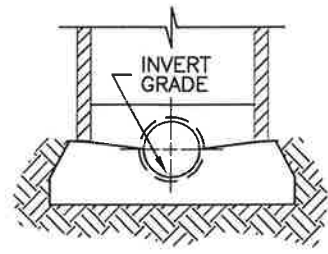

SECTION A-A

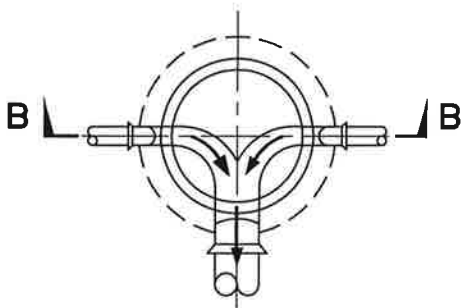

PLAN B

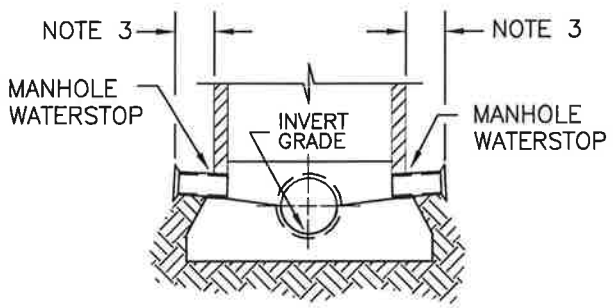

SECTION B-B

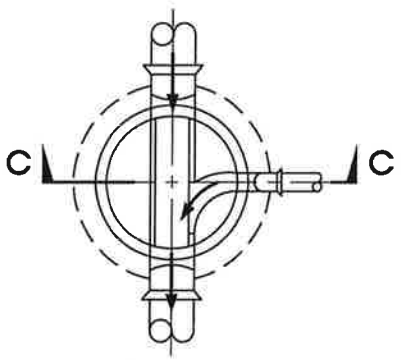

PLAN C

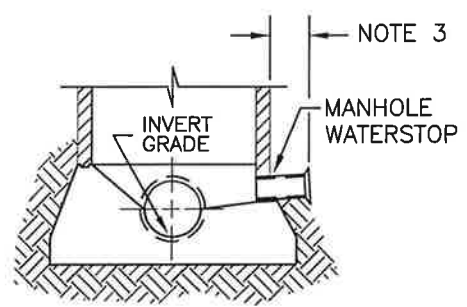

SECTION C-C

NOTES:

1. ALL CONCRETE USED IN MANHOLE SHALL BE PER PAGE 100.00.
2. PIPE MAY BE LAID THROUGH A LINE MANHOLE EXCEPT WHEN A GRADE OR LINE CHANGE OCCURS. MINIMUM DROP THROUGH ALL OTHER MANHOLES SHALL BE THE DIFFERENCE IN DIAMETERS OF THE UPSTREAM AND DOWNSTREAM PIPES OR 0.20 FT., WHICHEVER IS GREATER.
3. WHEN CLAY PIPE IS INSTALLED, PIPE SECTION SHALL NOT EXTEND MORE THAN 12" FROM SIDE OF MANHOLE.
4. WHEN ABS OR PVC PIPE IS USED, THE BARREL OF THE PIPE SHALL BE PRE-PRIMED WITH SOLVENT AND SPRINKLED WITH SAND IN ORDER TO PROVIDE A WATERTIGHT SEAL BETWEEN THE PIPE AND CONCRETE. THIS REQUIREMENT IS IN ADDITION TO THE USE OF THE WATERSTOP.
5. PRECAST CONCRETE BASES MANUFACTURED BY COOK CONCRETE PRODUCTS, OR TEICHERT AGGREGATE, OR EQUAL MAY BE USED IN LIEU OF POURED IN-PLACE BASES.

F:\STANDARDS\CONSTRUCTION STANDARDS\DWG\300\36300.DWG, 8.5X11.PDF, 1/26/2018 8:14:55 AM, DANIELS

DWG DATE: 1/98		SCALE: NTS	CITY OF REDDING • PUBLIC WORKS DEPARTMENT • ENGINEERING DIVISION	
2	1/18	NOTES UPDATE	APPROVED BY  1/26/18 CITY ENGINEER	
1	7/13			
MARK	DATE	REVISION	<h2>MANHOLE BASE DETAIL</h2>	



ACCEPTABLE MANUFACTURERS
DOMESTIC MANUFACTURER ONLY
CONTACT CITY OF REDDING
(530) 224-6068

TOP OF COVER

MARKINGS ON ALL STORM
DRAIN COVERS SHALL READ
"SANITARY SEWER"

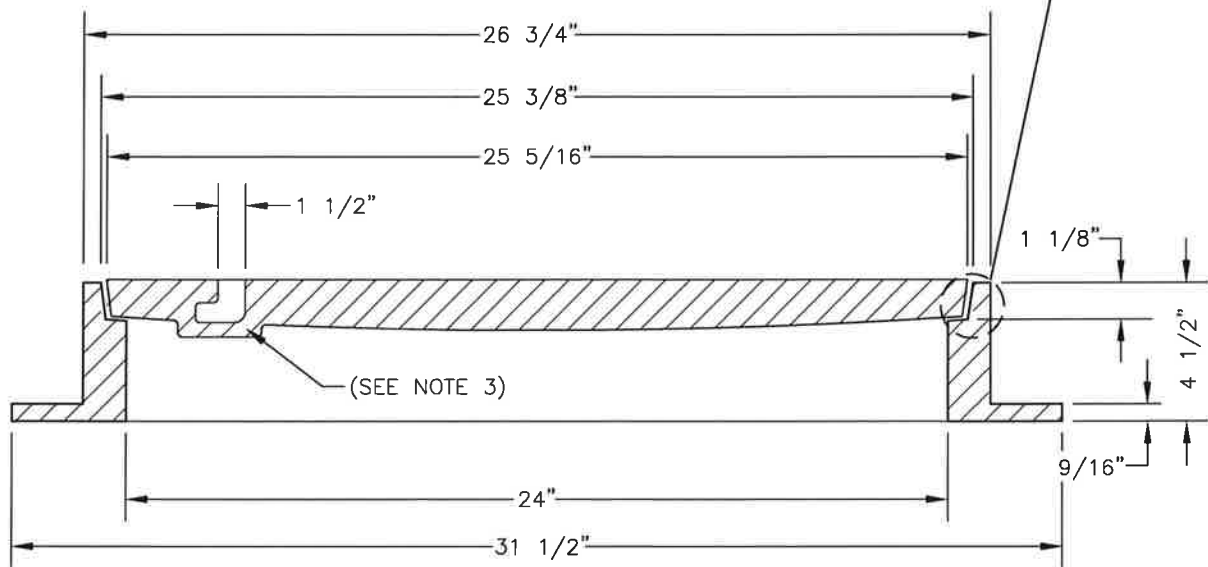
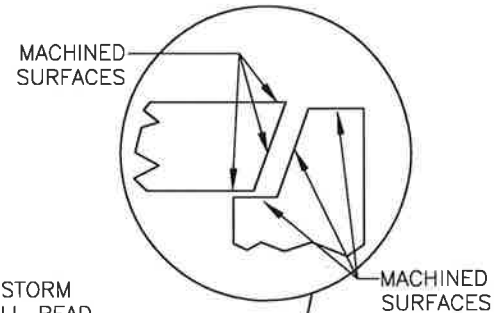

COVER SECTION

NOTES:

1. FRAME AND COVER FULLY MACHINED ON SURFACES AS SHOWN TO PROVIDE NO-ROCK, NO-STICK FIT.
2. STANDARD COVER MARKINGS AVAILABLE: "SANITARY SEWER". CASTING SHALL BE ORDERED WITH THE APPROPRIATE MARKING.
3. CASTING SHALL BE FURNISHED WITH CLOSED PICKHOLES.
4. ALL PARTS OF ACCEPTABLE ASSEMBLIES SHALL BE INTERCHANGEABLE.

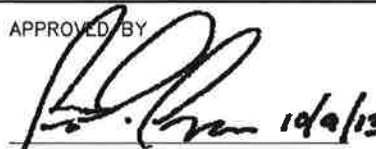
DWG DATE: 1/92		SCALE: NTS	CITY OF REDDING • PUBLIC WORKS DEPARTMENT • ENGINEERING DIVISION	
8	7/13	UPDATE	APPROVED BY  10/9/13 CITY ENGINEER	24 INCH SEWER MANHOLE COVER ASSEMBLY (STREET TYPE)
7	7/13	EDIT NOTES		
6	2/03	DECOR. COVER		
MARK	DATE	REVISION		



ACCEPTABLE MANUFACTURERS
DOMESTIC MANUFACTURER ONLY
CONTACT CITY OF REDDING
(530) 224-6068

HOLES FOR 1/2" DIA.
RED HEAD MULTI SET
DROP-IN ANCHORS (OR
APPROVED EQUAL) MIN.
2 1/2" EMBEDMENT
(TYP. OF 4)

MARKINGS ON ALL STORM
DRAIN COVERS SHALL READ
"SANITARY SEWER"

TOP OF COVER

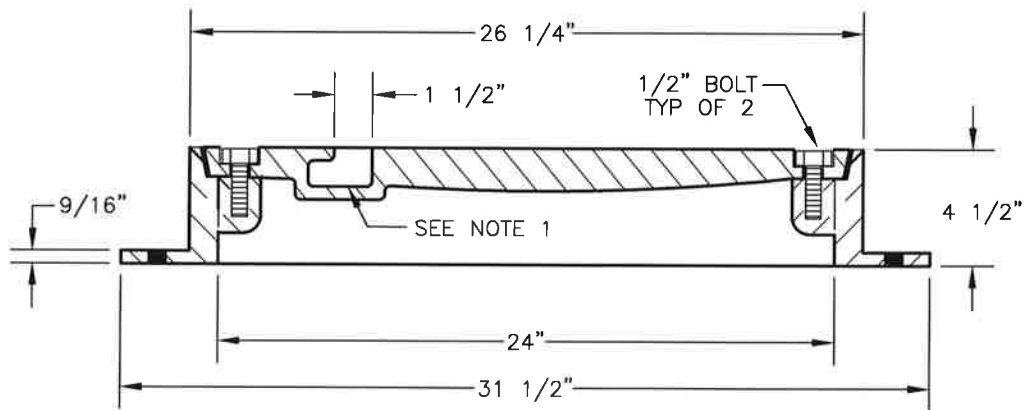

COVER SECTION

NOTES:

1. CASTING SHALL BE FURNISHED WITH CLOSED PICK HOLES.
2. ALL PARTS OF ACCEPTABLE ASSEMBLIES SHALL BE INTERCHANGEABLE.

DWG DATE: 1/93 SCALE: NTS CITY OF REDDING • PUBLIC WORKS DEPARTMENT • ENGINEERING DIVISION

MARK	DATE	REVISION	APPROVED BY
			<i>[Signature]</i> 10/2/13
			CITY ENGINEER

**SEWER MANHOLE
COVER ASSEMBLY—
BOLT DOWN**

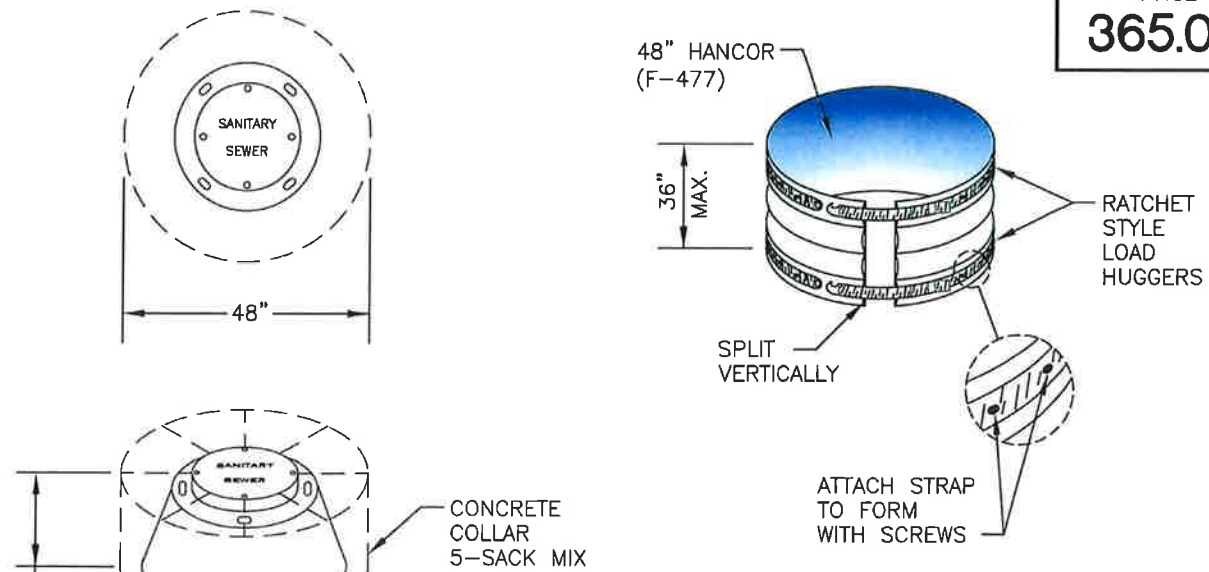

CONCRETE BUNKER FORM

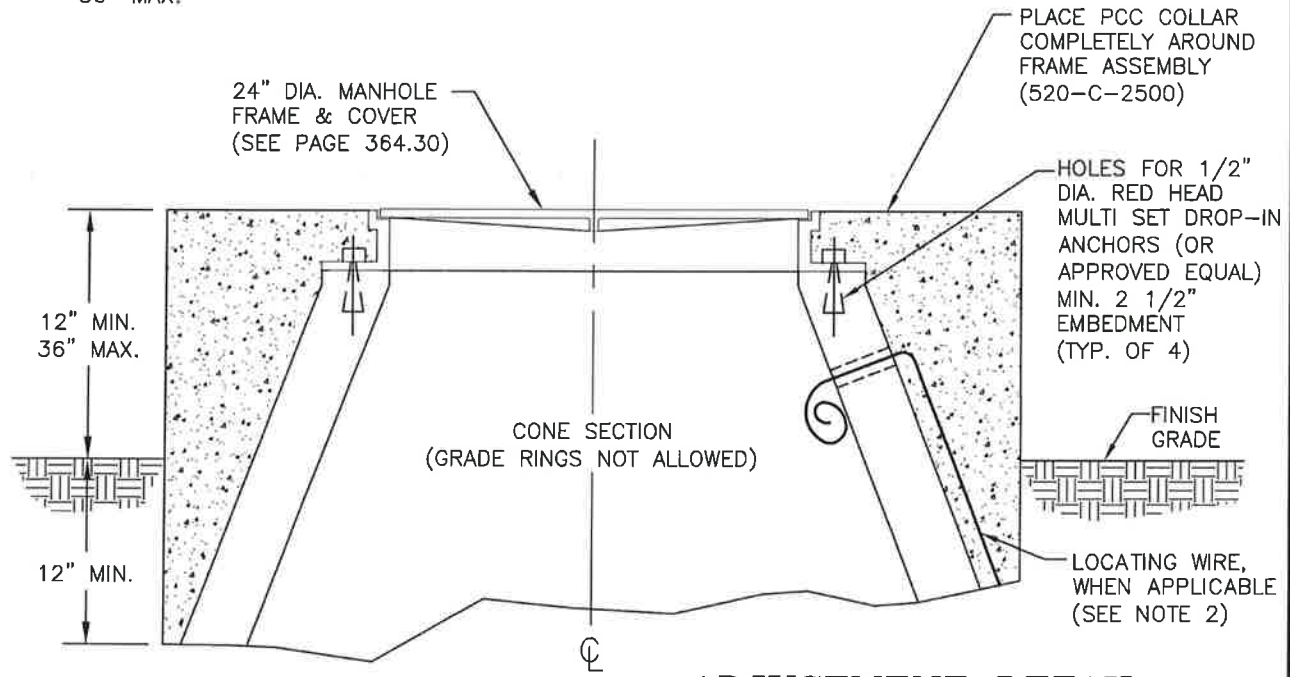

ADJUSTMENT DETAIL

TO BE USED IN UNIMPROVED AREAS
(SHOWING REQUIRED FRAME ASSEMBLY ANCHORAGE)

NOTE:

1. FOR SEWER MANHOLE CONSTRUCTION, SEE PAGE 360.00.
2. WHEN MANHOLE IS PART OF A NON-METALLIC PIPE NETWORK, LOCATING WIRE PER PAGE 608.00 SHALL BE MAINTAINED. CORE 1" ϕ HOLE THRU MANHOLE AS NECESSARY TO MAINTAIN REQUIREMENT FOR EXCESS WIRE TO BE WITHIN 6"-12" OF THE FINISHED GRADE.

DWG DATE: 4/06		SCALE: NTS	CITY OF REDDING • PUBLIC WORKS DEPARTMENT • ENGINEERING DIVISION	
2	3/18	12" DIM	APPROVED BY  3/20/18 CITY ENGINEER	
1	7/13	UPDATE		
MARK	DATE	REVISION	SEWER MANHOLE ADJUSTMENT DETAILS -UNIMPROVED AREAS-	

P:\STANDARDS\CONSTRUCTION STANDARDS\DWG\365.00.DWG, 6.5X11.PDF, 3/20/2018 9:47:05 AM, DANIELS

REQUIREMENT:

1. SAND AND OIL INTERCEPTORS (ALSO REFERRED TO AS SOIs OR OIL/WATER SEPARATORS) ARE REQUIRED FOR INDUSTRIAL AND COMMERCIAL ESTABLISHMENTS WHERE IT IS NECESSARY TO CAPTURE SOLIDS (SAND, SILT, SEDIMENT, SLUDGE ETC.) AND/OR FLOATABLE MATERIAL (OIL, GREASE ETC.).
2. THIS STANDARD APPLIES TO ALL NEW CONSTRUCTION, TENANT IMPROVEMENTS, REMODELS, AND EXISTING SYSTEMS WHICH ARE IN NEED OF AN UPGRADE.
3. SOIs WILL BE SIZED FROM INFORMATION SUBMITTED BY THE INDUSTRY, INDUSTRIAL WASTE SURVEY INFORMATION, OR BY CITY FIELD INSPECTION DATA.
4. STORMWATER MUST NOT ENTER THE WASH AREA. A ROOF IS REQUIRED OVER OUTDOOR WASH AREAS.

SIZING CRITERIA:

5. PARAMETERS—THE PARAMETERS FOR SIZING SOI UNITS ARE HYDRAULIC LOADING, RETENTION TIME, AND STORAGE FACTOR FOR ONE OR MORE FIXTURES OR INDUSTRIAL APPLICATIONS.
6. SIZING FORMULA—THE SIZE OF THE SOI WILL BE DETERMINED BY USE OF THE FOLLOWING FORMULA:

$$\begin{matrix} \text{NUMBER OF UNITS} & \times & \text{WASTE FLOW} & \times & \text{RETENTION} & \times & \text{STORAGE} & = & \text{INTERCEPTOR SIZE} \\ \text{WASHED PER HOUR*} & & \text{RATE**} & & \text{TIME***} & & \text{FACTOR****} & & \text{(LIQUID CAPACITY)} \end{matrix}$$

- * NUMBER OF UNITS WASHED PER HOUR (I.E., AUTOS, ENGINES, PARTS, ETC.)
 - ** WASTE FLOW RATE—GALLONS PER UNIT CLEANED (FOR INTERMITTENT USE), OR GALLONS PER HOUR (FOR CONSTANT USE)
 - *** RETENTION TIME 2.0 HOURS
 - **** STORAGE FACTORS—VEHICLE/EQUIPMENT/PARTS, ETC. WASHING
- | | |
|---|-----------|
| A. SELF SERVICE/PUBLIC | 1.5 HOURS |
| B. EMPLOYEE OPERATED AUTOMATED/COMMERCIAL | 2.0 HOURS |
| C. OTHER INDUSTRIAL/COMMERCIAL APPLICATIONS | 2.0 HOURS |

7. THE MINIMUM SIZE SOI ALLOWED BY THE CITY IS 100 GALLONS.

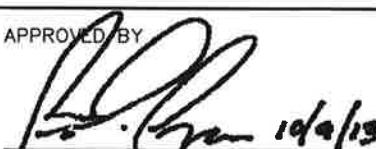
DWG DATE: 2/03		SCALE: NTS	CITY OF REDDING • PUBLIC WORKS DEPARTMENT • ENGINEERING DIVISION	
			APPROVED BY	SAND AND OIL INTERCEPTORS (SOI)
3 2	7/13 2/03	UPDATE REDRAWN	 10/4/13	
MARK	DATE	REVISION	CITY ENGINEER	

DESIGN:

8. ALL NEW CONSTRUCTION AND UPGRADES SHALL BE CONSTRUCTED TO INCLUDE A SAMPLE MONITORING STATION.
9. THE USE OF ALTERNATE PRETREATMENT SYSTEMS IN CONJUNCTION WITH OR IN LEIU OF AN SOI UNIT MUST BE APPROVED BY THE CITY'S INDUSTRIAL WASTE DIVISION. DESIGN SPECS MUST BE SUBMITTED WITH THE APPLICATION PAPERWORK OR THE PLUMBING PLANS.
10. IF AN EXISTING SOI IS UNDERSIZED AND IS STRUCTURALLY SOUND AND INSTALLED PROPERLY, A BUSINESS OR OWNER MAY INSTALL AN ADDITIONAL SOI IN SERIES WITH THE EXISTING SOI TO SATISFY THE TOTAL SIZE CAPACITY REQUIRED.
11. SANITARY TEES MUST BE INSTALLED AT THE INLET AND OUTLET OF EACH INTERCEPTOR. THE SANITARY TEE SHALL BE INSTALLED SO THE TOP OPENING OF THE SANITARY TEE IS VISIBLE AND ACCESSIBLE FROM THE MANHOLE LIDS.
12. THE SOI SHALL BE INSTALLED AS SHALLOW AS POSSIBLE. THE BOTTOM OF THE SOI SHALL NOT BE GREATER THAN 15 FEET BELOW GRADE TO FACILITATE ROUTINE PUMPING OR EXCEED THE TANK MANUFACTURER'S DESIGN CRITERIA FOR MAXIMUM EARTH COVER (TOP OF TANK TO GRADE).
13. NO MORE THAN 24 INCHES OF GRADE RINGS SHALL BE USED IN AN INTERCEPTOR INSTALLATION. ALL FLEXIBLE JOINT SEALS OF RISERS AND COVER RINGS, AND ALL GROUT OF INTERNAL PLUMBING SHALL BE THE RESPONSIBILITY OF THE OWNER/OPERATOR AND/OR CONTRACTOR. AN ECCENTRIC CONCRETE CONE OR REDUCING TOP (36 INCH TO 24 INCH MANHOLE OR 48 INCH TO 24 INCH MANHOLE) SHALL BE USED IF THE TOP OF THE OGI IS GREATER THAN 24 INCHES BELOW FINISHED GRADE. (SEE CITY OF REDDING DESIGN SPECIFICATION PAGES 360.00, 360.10 AND 612.00.)
14. MANHOLE COVERS FOR SOIs SHALL NOT BE THE BOLT-DOWN TYPE.
15. ALL SOIs SHALL BE PROPERLY INSTALLED AND MAINTAINED. ALL INTERNAL PLUMBING OF PROPER DESIGN AND LENGTH SHALL BE IN PLACE AT ALL TIMES. SOIs ARE REQUIRED TO BE PUMPED WHEN 25% OF THE INTERNAL CAPACITY IS OCCUPIED BY OILS, GREASE AND/OR SOLIDS. PUMPING IS TYPICALLY REQUIRED EVERY 12 MONTHS DEPENDING ON USE. INTERCEPTOR PUMPING IS THE RESPONSIBILITY OF THE BUSINESS OPERATOR UNLESS OTHER AGREEMENTS HAVE BEEN MADE BETWEEN THE BUSINESS OPERATOR AND PROPERTY OWNER OR PROPERTY MANAGER. AT NO TIME IS THE CITY OF REDDING RESPONSIBLE FOR MAINTENANCE OF A PRIVATE SAND AND OIL INTERCEPTOR.
16. GRATED OPENINGS ARE NOT ALLOWED OVER THE SOI. TRENCH DRAINS AND DROP INLETS MUST BE SEPARATE FROM THE SOI TANK.
17. SOIs AND HYDROMECHANICAL SEPARATORS WILL BE INSPECTED BY THE CITY OF REDDING TO ENSURE PROPER INSTALLATION AND MAINTENANCE
18. SLUDGE AND OTHER WASTE HAULING MANIFESTS MUST BE RETAINED FOR A MINIMUM OF 3 YEARS.

REQUIREMENT:

1. OIL AND GREASE INTERCEPTORS (ALSO REFERRED TO AS GRAVITY GREASE INTERCEPTORS, OR OGIs) ARE REQUIRED AT COMMERCIAL AND INDUSTRIAL FOOD AND BEVERAGE FACILITIES WHERE IT IS NECESSARY TO CAPTURE GREASE, OIL AND FOOD SOLIDS BEFORE WASTEWATER ENTERS THE CITY SANITARY SEWER SYSTEM.
2. THIS STANDARD APPLIES TO ALL NEW CONSTRUCTION, TENANT IMPROVEMENTS, REMODELS, AND EXISTING SYSTEMS WHICH ARE IN NEED OF AN UPGRADE. OGIs MUST BE INSTALLED OUTDOORS OR IN A LOCATION OUTSIDE OF THE FOOD PREPARATION AREA.
3. OGIs WILL BE SIZED FROM INFORMATION SUBMITTED ON THE FOOD FACILITY WASTEWATER DISCHARGE SURVEY/APPLICATION 2. SIZING CRITERIA WILL FOLLOW CALIFORNIA PLUMBING CODE CHAPTER 10. GRAVITY GREASE INTERCEPTORS SHALL HAVE A MINIMUM RETENTION TIME OF 30 MINUTES AND BE A MINIMUM SIZE OF 500 GALLONS.

SIZING CRITERIA:

DRAINAGE FIXTURE UNITS (DFUs)	OIL AND GREASE INTERCEPTOR (OGI OR GRAVITY GREASE INTERCEPTOR) IN GALLONS
≤8	500
21	750
35	1000
90	1250
172	1500
216	2000
307	2500
342	3000
428	4000
576	5000
720	7500

4. THE MINIMUM SIZE OGI ALLOWED BY THE CITY IS 500 GALLONS. FOR VERY LARGE FACILITIES, THE SIZE WILL BE ESTABLISHED ON A CASE BY CASE BASIS. FOR OGIs LARGER THAN 3,000 GALLONS, MULTIPLE OGIs SHALL BE INSTALLED IN SERIES TO FACILITATE COMPLETE PUMPING REQUIRED FOR MAINTENANCE (I.E., TWO 2,500 GALLON OGIs MUST BE USED FOR 5,000 GALLON CAPACITY).

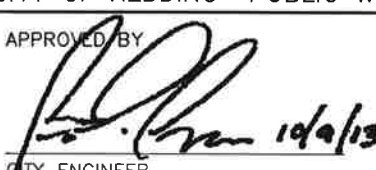
DWG DATE: 2/03		SCALE: NTS	CITY OF REDDING • PUBLIC WORKS DEPARTMENT • ENGINEERING DIVISION	
3	7/13	UPDATE	APPROVED BY  10/9/13 CITY ENGINEER	
2	2/03	REDRAWN		
MARK	DATE	REVISION	OIL AND GREASE INTERCEPTORS (OGI)	

DESIGN:

5. ALL NEW CONSTRUCTION AND UPGRADES SHALL BE CONSTRUCTED TO INCLUDE A SAMPLE MONITORING STATION.
6. ALL FOOD WASTES SHOULD BE SCREENED AND DISPOSED IN SOLID WASTE. GARBAGE GRINDERS ARE STRONGLY DISCOURAGED. IF A GARBAGE GRINDER IS INSTALLED, IT MUST BE PLUMBED TO THE GREASE INTERCEPTOR.
7. IF AN EXISTING OGI IS UNDERSIZED AND IS STRUCTURALLY SOUND AND INSTALLED PROPERLY, A BUSINESS OR OWNER MAY INSTALL AN ADDITIONAL OGI IN SERIES WITH THE EXISTING OGI TO SATISFY THE TOTAL CAPACITY REQUIREMENT.
8. SANITARY TEES MUST BE INSTALLED AT THE INLET AND OUTLET OF EACH INTERCEPTOR. THE SANITARY TEE SHALL BE INSTALLED SO THE TOP OPENING OF THE SANITARY TEE IS VISIBLE AND ACCESSIBLE FROM THE MANHOLE LIDS.
9. THE OGI SHALL BE INSTALLED AS SHALLOW AS POSSIBLE. THE BOTTOM OF THE OGI SHALL NOT BE GREATER THAN 15 FEET BELOW GRADE TO FACILITATE ROUTINE PUMPING OR EXCEED THE TANK MANUFACTURER'S DESIGN CRITERIA FOR MAXIMUM EARTH COVER (TOP OF TANK TO GRADE).
10. NO MORE THAN 24 INCHES OF GRADE RINGS SHALL BE USED IN AN INTERCEPTOR INSTALLATION. ALL FLEXIBLE JOINT SEALS OF RISERS AND COVER RINGS, AND ALL GROUT OF INTERNAL PLUMBING SHALL BE THE RESPONSIBILITY OF THE OWNER/OPERATOR AND/OR CONTRACTOR. AN ECCENTRIC CONCRETE CONE OR REDUCING TOP (36 INCH TO 24 INCH MANHOLE OR 48 INCH TO 24 INCH MANHOLE) SHALL BE USED IF THE TOP OF THE OGI IS GREATER THAN 24 INCHES BELOW FINISHED GRADE. (SEE CITY OF REDDING DESIGN SPECIFICATION PAGES 360.00, 360.10 AND 612.00.)
11. MANHOLE COVERS FOR OGIs SHALL NOT BE THE BOLT-DOWN TYPE.
12. ALL OGIs SHALL BE PROPERLY INSTALLED AND MAINTAINED. ALL INTERNAL PLUMBING OF PROPER DESIGN AND LENGTH SHALL BE IN PLACE AT ALL TIMES. OGIs ARE REQUIRED TO BE PUMPED WHEN 25% OF THE INTERNAL CAPACITY IS OCCUPIED BY OILS, GREASE AND/OR SOLIDS. PUMPING IS TYPICALLY REQUIRED EVERY 3 MONTHS DEPENDING ON USE. INTERCEPTOR PUMPING IS THE RESPONSIBILITY OF THE BUSINESS OPERATOR UNLESS OTHER AGREEMENTS HAVE BEEN MADE BETWEEN THE BUSINESS OPERATOR AND PROPERTY OWNER OR PROPERTY MANAGER. AT NO TIME IS THE CITY OF REDDING RESPONSIBLE FOR MAINTENANCE OF A PRIVATE OIL AND GREASE INTERCEPTOR.
13. HYDROMECHANICAL GREASE INTERCEPTORS (FORMERLY REFERRED TO AS GREASE TRAPS) OR OTHER PRE-MANUFACTURED DEVICES WILL ONLY BE ALLOWED WHERE SPACE OR OTHER DESIGN CONSTRAINTS PROHIBIT THE INSTALLATION OF A GRAVITY GREASE INTERCEPTOR. DESIGN SPECS MUST BE SUBMITTED WITH THE APPLICATION PAPERWORK OR THE PLUMBING PLANS.
14. OGIs AND HYDROMECHANICAL GREASE INTERCEPTORS WILL BE INSPECTED BY THE CITY OF REDDING TO ENSURE PROPER INSTALLATION AND MAINTENANCE.

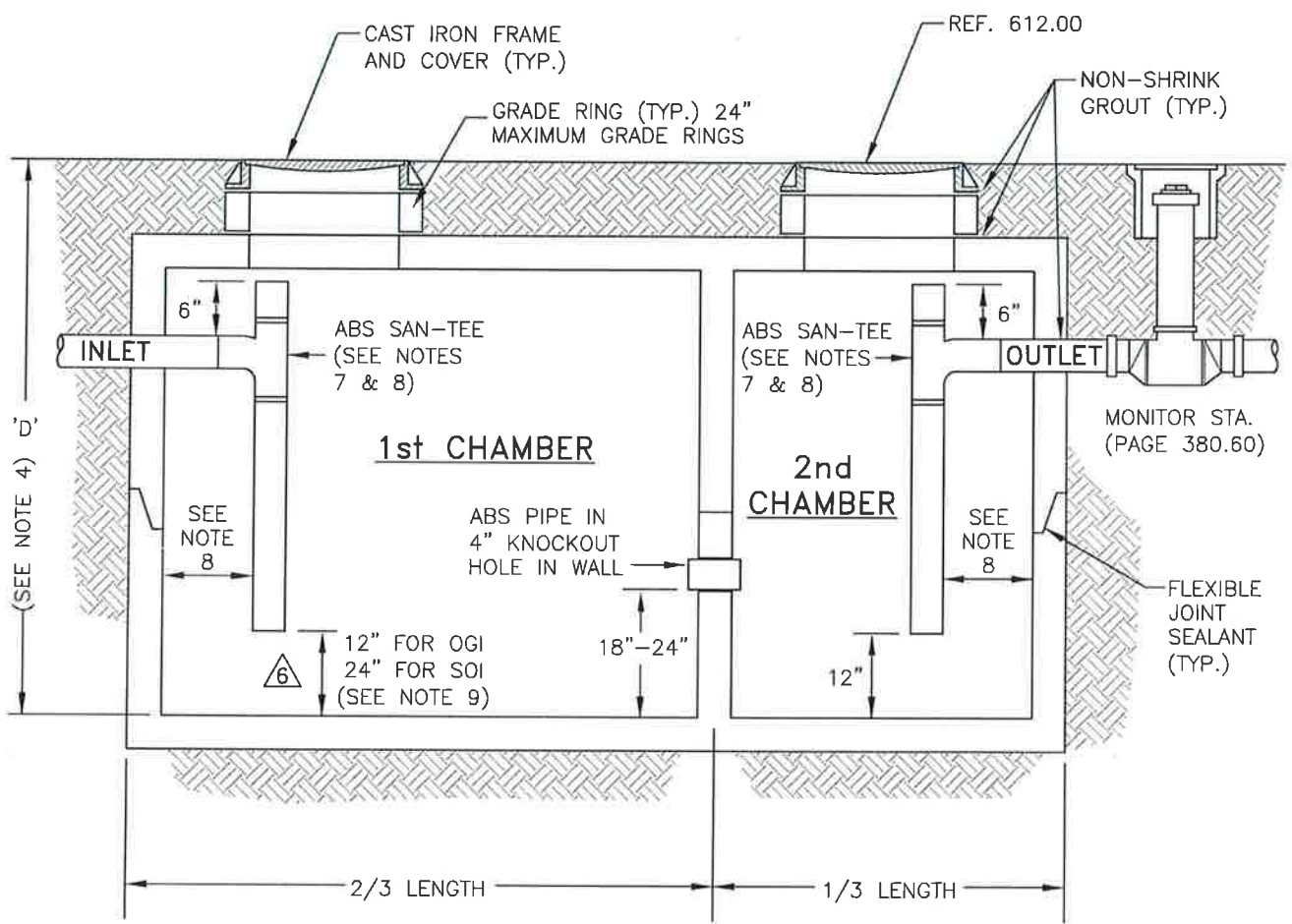

NOTES:

1. TANK SHALL HAVE A MINIMUM WALL THICKNESS OF 3".
2. SYSTEMS THAT MAY BE EXPOSED TO TRAFFIC AND/OR PARKING ON OR NEAR THE TANKS OR THE ACCESS COVERS SHALL BE DESIGNED TO AASHTO HS20-44 LOADING.
3. BACKFILL SHALL BE CLASS 'A' IN STREET R/W AND CLASS 'B' IN ALL OTHER LOCATIONS PER PAGE 610.00 AND PER TANK MANUFACTURER'S BEDDING RECOMMENDATIONS.
4. DISTANCE BETWEEN GRADE AND BOTTOM OF TANK 'D' SHALL NOT EXCEED 15 FEET OR EXCEED THE TANK MANUFACTURER'S CRITERIA FOR MAXIMUM EARTH COVER (TOP OF TANK TO GRADE).
5. ECCENTRIC MANHOLE CONE OR REDUCING TOP (36" TO 24" OR 48" TO 24") SHALL BE USED WHEN THE TOP OF TANK TO GRADE IS GREATER THAN 24" (SEE PAGES 360.00 AND 360.10).
6. IF ECCENTRIC CONES ARE INSTALLED, THE VERTICAL WALL SHALL BE OVER THE INLET AND OUTLET ENDS OF THE TANK.
7. INLET AND OUTLET PLUMBING SHALL BE SECURED WITH NON-SHRINK GROUT. SAN-TEES SHALL BE GLUED TO THE INLET AND OUTLET PLUMBING.
8. ABS SAN-TEES SHALL BE ALIGNED WITH EDGE OF ACCESS COVER TO ALLOW CLEANING.
9. OIL AND GREASE INTERCEPTOR (OGI) SHALL HAVE 12" CLEARANCE BELOW INLET SAN-TEE
6 SAND AND OIL INTERCEPTOR (SOI) SHALL HAVE 24" CLEARANCE BELOW INLET SAN-TEE

DWG DATE: 6/92		SCALE: NTS	CITY OF REDDING • PUBLIC WORKS DEPARTMENT • ENGINEERING DIVISION	
		ADD NOTE	APPROVED BY CITY ENGINEER	
6	3/18	EDIT NOTE		
5	8/16	REVISE NOTES		
4	7/13	NEW COM. STD		
3	2/03		SAND & OIL AND OIL & GREASE INTERCEPTOR SOI AND OGI	
MARK	DATE	REVISION		

P:\STANDARDS\CONSTRUCTION STANDARDS\DWG\300\380.40.DWG, 8.5X11 PDF, 3/19/2018 8:37:31 AM, DANIELS

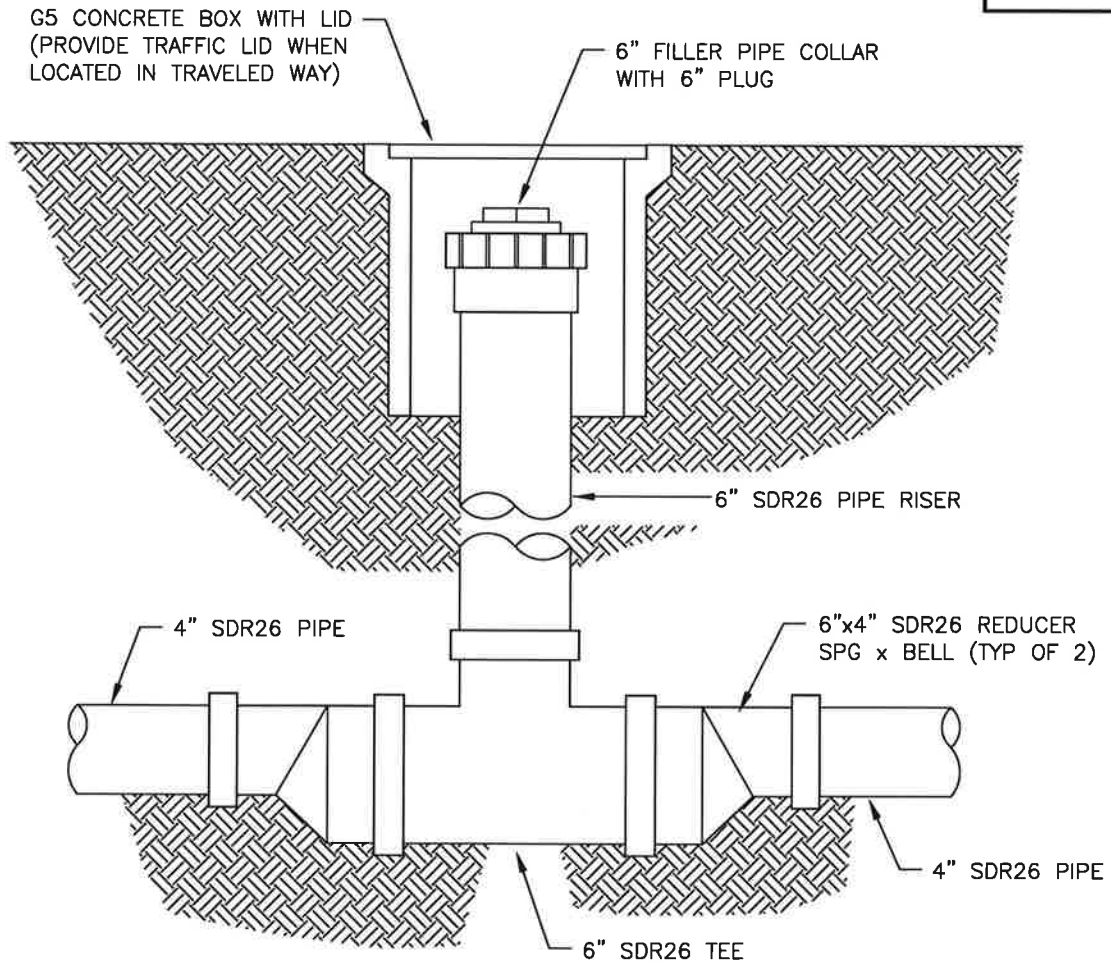

PARTS LIST

6" SDR26 TEE	1 EA
6"x4" SDR26 REDUCER (SPG x BELL)	2 EA
6" FILLER PIPE COLLAR	1 EA
6" PLUG	1 EA
G5 CONCRETE BOX	1 EA
G5 SEWER LID	1 EA
(IF REQUIRED)	
4" ABS COUPLING	1 EA
4" ABS x SDR BUSHING	1 EA

NOTE:

1. MONITOR STATION MUST BE INSTALLED LEVEL.

DWG DATE: 7/92 SCALE: NTS CITY OF REDDING • PUBLIC WORKS DEPARTMENT • ENGINEERING DIVISION

			APPROVED BY
5	7/13	UPDATE	
4	4/06	REV. PARTS	
MARK	DATE	REVISION	CITY ENGINEER

**INTERCEPTOR
MONITOR STATION**

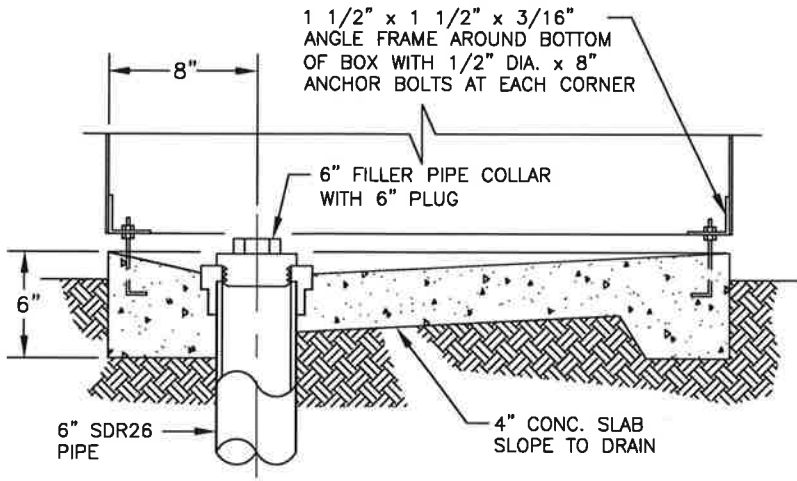

SLAB DETAIL

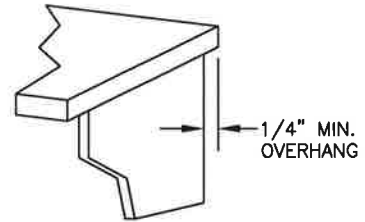

LID DETAIL

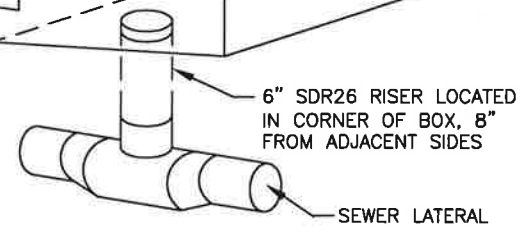
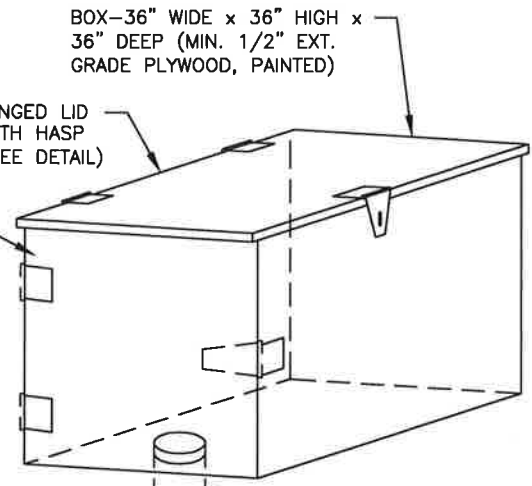

BOX DETAIL

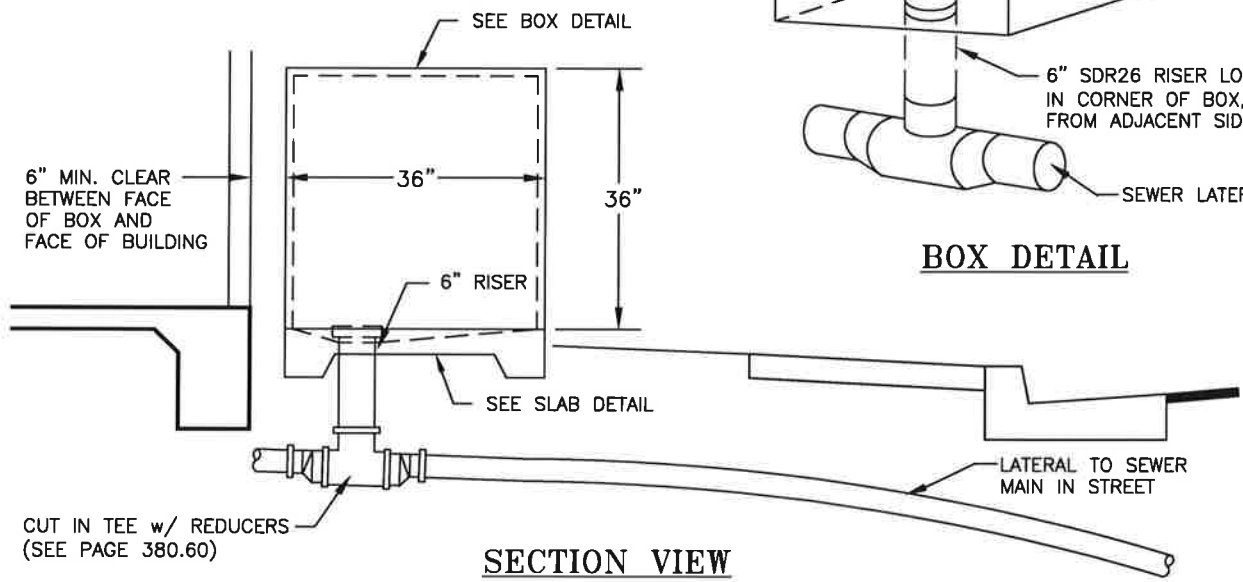

SECTION VIEW

NOTE:

1. BOX LOCATED ON PRIVATE PROPERTY SHALL BE IN AN AREA THAT ALLOWS 24 HR. ACCESS BY CITY OF REDDING PERSONNEL

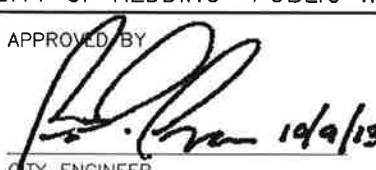
DWG DATE: 3/88		SCALE: NTS	CITY OF REDDING • PUBLIC WORKS DEPARTMENT • ENGINEERING DIVISION	
4	7/13	UPDATE	APPROVED BY  10/9/13 CITY ENGINEER	
3	4/06	REV. PARTS		
MARK	DATE	REVISION		
			ABOVE GRADE WASTEWATER MONITORING STATION	

APPENDIX D
REVISION RECORDS

Sewer System Management Plan (SSMP) Revision Record

Section Revised	Page Revised	Date	Revised By
SSMP Developed	n/a	5/1/2011	Burney Water District
SSMP Requirement Background/Document Organization	Entire Section Revised	02/2017	Pace Engineering Job #306.29.200
District Service Area and Sewer System	Entire Section Revised	02/2017	Pace Engineering Job #306.29.200
Section 2: Organization	Entire Section Revised	02/2017	Pace Engineering Job #306.29.200
Section 3: Legal Authority	Entire Section Revised	02/2017	Pace Engineering Job #306.29.200
Section 4: Operations and Maintenance	Entire Section Revised	02/2017	Pace Engineering Job #306.29.200
Section 5: Design and Performance Provision	Entire Section Revised	02/2017	Pace Engineering Job #306.29.200
Section 6: Emergency Response Plan	Entire Section Revised	02/2017	Pace Engineering Job #306.29.200
Section 7: Fats, Oils, and Grease Control Program	Entire Section Revised	02/2017	Pace Engineering Job #306.29.200
Section 8: System Evaluation and Capacity Assurance Plan	Entire Section Revised	02/2017	Pace Engineering Job #306.29.200
Section 9: Monitoring, Measurements, and Program Modifications	Entire Section Revised	02/2017	Pace Engineering Job #306.29.200
Section 10: SSMP Audits	Entire Section Revised	02/2017	Pace Engineering Job #306.29.200
Appendix A: Names & Contact Information of Current Staff	Added Appendix A	02/2017	Pace Engineering Job #306.29.200
Appendix B: Sanitary Sewer Overflow Emergency Response Plan	SSOERP Developed	02/2017	Pace Engineering Job #306.29.200
Appendix C: City of Redding Std Specification and Details for Design and Construction of WW Collection Facilities	Added Appendix C	02/2017	Pace Engineering Job #306.29.200
Appendix D: Burney Water District Confined Space Program	Added Appendix D	02/2017	Pace Engineering Job #306.29.200
Appendix E: Burney Water District Occupational IIPP	Added Appendix E	02/2017	Pace Engineering Job #306.29.200
Appendix F: SSMP Revision Record	Added Appendix F	02/2017	Pace Engineering Job #306.29.200
Appendix D: Burney Water District Confined Space Program	Removed Appendix D	01/2023	BWD DZ
Appendix E: Burney Water District Occupational IIPP	Removed Appendix E	01/2023	BWD DZ
Appendix F: SSMP Revision Record	Changed Appendix F to D	01/2023	BWD DZ
Appendix B: Sanitary Sewer Overflow Emergency Response Plan	Added APPENDIX C: Water Quality Sampling Guidelines for Spills Greater Than 50,000 Gallons	01/2023	BWD DZ
Appendix B: Sanitary Sewer Overflow Emergency Response Plan	Updated Table 1 - Chain of Communication	01/2023	BWD and PACE Engineering
Appendix B: Sanitary Sewer Overflow Emergency Response Plan	Updated SSO Reporting Requirements Flow Chart to include 50,000 Gallon Spill and Technical Report	01/2023	BWD and PACE Engineering
Update SSMP	Reviewed and Revised Document as needed	01/2023	BWD and PACE Engineering
Appendix B: Sanitary Sewer Overflow Emergency Response Plan	Revised SSO Reporting Form	01/2023	BWD DZ